

# NTI – TRINITY Ti

## INSTALLATION AND OPERATING INSTRUCTIONS

VERSION DATE: 7-20-10

### TABLE OF CONTENTS

1.0 SPECIFICATIONS .....	4
2.0 BOILER LOCATION .....	5
3.0 VENTING.....	6
4.0 CONDENSATE DRAIN.....	13
5.0 INSTALLING GAS PIPING .....	14
6.0 LIGHTING THE APPLIANCE .....	15
7.0 GAS VALVE AND BURNER SET-UP.....	17
8.0 BOILER AND HEATING SYSTEM PIPING .....	20
9.0 COMBI BOILER DHW PLUMBING AND OPERATION .....	26
10.0 WIRING .....	30
11.0 SENTRY 2100 CONTROLLER.....	37
12.0 TROUBLESHOOTING .....	41
13.0 SEQUENCE OF OPERATION.....	44
14.0 WIRING SCHEMATIC.....	45
15.0 INSTALLATION CHECKLIST .....	46
16.0 ANNUAL MAINTENANCE AND INSPECTION.....	47
17.0 PARTS LIST .....	49

### HAZARD SYMBOL DEFINITIONS



Danger Sign: Indicates a hazardous situation which, if not avoided, will result in serious injury or death.



Warning Sign: Indicates a hazardous situation which, if not avoided, could result in serious injury or death.



Caution Sign plus Safety Alert Symbol: Indicates a hazardous situation which, if not avoided, could result in minor or moderate injury.



Caution Sign without Safety Alert Symbol: Indicates a hazardous situation which, if not avoided, could result in property damage.



Notice Sign: Indicates a hazardous situation which, if not avoided could result in property damage.



## 0.0 INTRODUCTION

### General Installation Requirements

The installation of your NTI Trinity Ti gas boiler must conform to the requirements of this manual, your local authority, and the National Fuel Gas Code ANSI Z223.1 and or CAN/CGA B149 Installation Codes. Where required by the Authority, the installation must conform to the standard for “Controls and Safety Devices for Automatically Fired Boilers ANSI/ASME CSD-1.

This document pertains to the correct installation and operation of NTI Trinity Ti boiler models Ti100, Ti150 and Ti200. The instructions detailed in this document supersede any and all previous instructions provided by NTI, written or otherwise. Each unit is provided with the following:

- 1) Installation and Operation Instruction Manual for Trinity Ti Series,
- 2) Trinity Users Manual and,
- 3) Trinity Natural to LP Conversion Kit \*

\* The conversion kit is required to convert the appliance so it will safely operate with Propane Gas.



Read and understand this entire document prior to proceeding with the installation of the Trinity Ti. Failure to follow the instructions outlined in this document will result in property damage, serious injury or death.

### User Responsibilities

This appliance must be installed and serviced by a qualified installer or service technician. This appliance must be serviced and inspected annually when operating in normal residential applications. Demanding applications or extreme conditions (i.e. commercial) may require more frequent service and inspection. As the User/Owner of this equipment, you are responsible for ensuring the maintenance is performed at the required intervals. It is also the Users responsibility to ensure the Vent and Combustion-Air Intake termination is kept clear of ice and snow or any other obstruction. Failure to follow these instructions could result in fire, serious injury, or death.



Failure to have the appliance properly serviced and inspected on a regular basis may result in property damage, serious injury or death.



Failure to keep the Vent and Combustion Air Intake clear of ice, snow, and other debris may result in property damage, serious injury, or death.

### Installer Responsibilities

As the installing technician it is your responsibility to ensure the installation is performed in accordance with this instruction manual as well as any applicable local or National installation codes. It is also your responsibility to inform the User/Owner of their obligation with respect to the above description under “User Responsibilities”. Failure to follow this warning could result in fire, serious injury, or death.

#### **ATTENTION: LIQUEFIED PETROLEUM (LP) PROPANE**

The Trinity Ti is factory set to operate with Natural Gas. **BEFORE OPERATING WITH PROPANE**, the specified LP Conversion Kit must be installed to convert the appliance so it will operate safely with LP Propane. Listed below is the correct Natural to LP Propane Conversion Kit number for Trinity Ti100-200 boiler models. Note: kit number 82650-1 contains two LP conversion orifices. The smaller orifice, labeled 34, must be used in the Ti100, while the larger orifice, labeled 52, must be used in the Ti150 and Ti200.

Liquefied Petroleum (LP) propane gas is heavier than air; therefore, it is imperative that your Trinity Ti boiler is not installed in a pit or similar location that will permit heavier than air gas to collect. Local Codes may require appliances fueled with LP gas be provided with an approved means of removing unburned gases from the room. Check your local codes for this requirement.

#### **Natural to LP Propane Conversion Kit**

<u>NTI Series</u>	<u>Model Number</u>	<u>Kit Number</u>
Trinity Ti	100, 150, 200	82650-1



Failure to use the appropriate Natural to LP Conversion Kit when operating the Trinity Ti with Propane will result in extremely dangerous burner operation leading to property damage, serious injury or death. Refer to the above, **ATTENTION: LIQUEFIED PETROLEUM (LP) PROPANE** for correct conversion kit number.

### Appliance Vent / Air-Intake Piping



The Trinity Ti is a “Direct Vent” appliance requiring a “Special Venting System”. Vent and Combustion-Air Intake piping must be piped to the outdoors, using the vent material and rules outlined in these instructions. Failure to follow instructions will result in serious injury or death.

## IN THE STATE OF MASSACHUSETTS ONLY

(a) For all horizontally vented gas fueled equipment installed in every dwelling, building or structure used in whole or in part for residential purposes, including those owned and operated by the Commonwealth and where the side wall exhaust vent termination is less than seven (7) feet above finished grade in the area of the venting, including but not limited to decks and porches, the following requirements shall be satisfied:

1. **INSTALLATION OF CARBON MONOXIDE DETECTORS** At the time of installation of the side wall horizontal vented gas fueled equipment, the installing plumber or gas fitter shall observe that a hard wired carbon monoxide detector with an alarm and battery back-up is installed on the floor level where the gas equipment is to be installed and on each additional level of the dwelling, building or structure served by the equipment. It shall be the responsibility of the property owner to secure the services of qualified licensed professionals for the installation of hard wired carbon monoxide detectors.
  - a. In the event that the side wall horizontally vented gas fueled equipment is installed in a crawl space or an attic, the hard wired carbon monoxide detector with alarm and battery back-up may be installed on the next adjacent floor level.
  - b. In the event that the requirements of this subdivision can not be met at the time of completion of installation, the owner shall have a period of 30 days to comply with the above requirements; provided, however, that during said 30 day period a battery operated carbon monoxide detector with an alarm shall be installed.
2. **APPROVED CARBON MONOXIDE DETECTORS** Each carbon monoxide detector as required in accordance with the above provisions shall comply with NFPA 720 and be ANSI/UL 2034 listed and IAS certified.
3. **SIGNAGE** A metal or plastic identification plate shall be permanently mounted to the exterior of the building at a minimum height of eight (8) feet above grade directly in line with the exhaust vent terminal for the horizontally vented gas fueled heating appliance or equipment. The sign shall read, in print size no less than one-half (1/2) inch in size, "***GAS VENT DIRECTLY BELOW. KEEP CLEAR OF ALL OBSTRUCTIONS***" (*plate included with appliance*).
4. **INSPECTION** The state or local gas inspector of the side wall horizontally vented gas fueled equipment shall not approve the installation unless, upon inspection, the inspector observes carbon monoxide detectors and signage installed in accordance with the provisions of 248 CMR 5.08(2)(a)1 through 4.

(b) **EXEMPTIONS:** The following equipment is exempt from 248 CMR 5.08(2)(a)1 through 4:

1. The equipment listed in Chapter 10 entitled "Equipment Not Required To Be Vented" in the most current edition of NFPA 54 as adopted by the Board; and
2. Product Approved side wall horizontally vented gas fueled equipment installed in a room or structure separate from the dwelling, building or structure used in whole or in part for residential purposes.

(c) **MANUFACTURER REQUIREMENTS – GAS EQUIPMENT VENTING SYSTEM PROVIDED:** When the manufacturer of Product Approved side wall horizontally vented gas equipment provides a venting system design or venting system components with the equipment, the instructions provided by the manufacturer for installation of the equipment and the venting system shall include:

1. Detailed instructions for installation of the venting system design or the venting system components; and
2. A complete parts list for the venting system design or venting system.

(d) **MANUFACTURER REQUIREMENTS – GAS EQUIPMENT VENTING SYSTEM NOT PROVIDED:** When the manufacturer of a Product Approved side wall horizontally vented gas fueled equipment does not provide the parts for venting the flue gases, but identifies "special venting systems", the following requirements shall be satisfied by the manufacturer.

## 1.0 SPECIFICATIONS

**Table 1-1 Specifications**

DESCRIPTION	Ti100	Ti150	Ti200
CSA Input Modulation <sup>1</sup> btu/hr [kw]	15,000 - 93,000 [4.4 - 29.3]	25,000 - 150,000 <sup>2</sup> [7.3 - 44.0]	25,000 - 199,000 [7.3 - 58.3]
DOE Heating Capacity <sup>1,3</sup> btu/hr [kw]	85,000 [24.9]	136,000 [39.8]	182,000 [53.3]
Net I=B=R Rating <sup>1,3</sup> btu/hr [kw]	74,000 [21.7]	118,000 [34.8]	158,000 [46.3]
DOE AFUE <sup>3</sup> %	95.1	95.1	95.1
Water Connections - NPT, in.	1 <sup>4</sup>	1 <sup>4</sup>	1
Gas Connection - NPT, in.	1/2	1/2	1/2
Vent/Air-Intake Pipe Diameter <sup>5</sup> , in. [mm]	3 [76]	3 [76]	3 [76]
Vent/Air-Intake, Max. Length, NG / LP ft. [m]	105 / 105 [32 / 32]	105 / 50 [32 / 15.2]	105 / 50 [32 / 15.2]
Dimensions H x W x D in. [mm]	22.5 x 15.5 x 16.75 <sup>6</sup> [571 x 394 x 425]	22.5 x 15.5 x 16.75 <sup>6</sup> [571 x 394 x 425]	22.5 x 15.5 x 18.25 [571 x 394 x 464]
Approx. Appliance Weight with Water, lbs [kg]	80 [36.3]	80 [36.3]	110 [49.9]

**Notes:**

- <sup>1</sup> Listed Input and Output ratings are at minimum vent lengths at Sea Level. Numbers will be lower with longer venting and/or altitudes greater than 2000 feet [610 m].
- <sup>2</sup> The maximum output when operating on LP-Gas is limited to 145,000 Btu/hr [42.5 kW].
- <sup>3</sup> Based on rating plate input capacities, using standard test procedures prescribed by the U.S. Department of Energy. Ratings have been confirmed by AHRI (GAMA).
- <sup>4</sup> Units sold in Canada are 3/4" NPT.
- <sup>5</sup> Trinity Ti units require a special venting system, use only vent materials and methods detailed in these instructions.
- <sup>6</sup> Ti100 and 150 units sold in Canada have a depth of 14.75".



This unit requires two people to lift it or property damage and personal injury may result.

### High Altitude Operation

The Trinity is designed to operate at its maximum listed capacity in installations less than or equal to 2000 ft [610 m] above Sea Level. Since the density of air decreases as elevation increases, maximum specified capacity should be de-rated for elevations above 2000 ft [610 m] in accordance with Table 1-2.

**Table 1-2 De-rate % for High Altitudes**

Elevations	2000 ft [610 m]	3000 ft [914 m]	4000 ft [1219 m]	4500 ft [1372 m]	5000 ft [1524 m]
In Canada <sup>1</sup>	de-rate by 5%	de-rate by 5%	de-rate by 5%	de-rate by 5%	de-rate % may vary
In USA <sup>2</sup>	-	de-rate by 4%	de-rate by 8%	-	de-rate by 12%

**Notes:**

- <sup>1</sup> Canada: Altitudes between 2000-4500 ft [610-1372 m], de-rate by 5%. Consult local authorities for de-rating capacities for altitudes above 4500 ft [1372 m].
- <sup>2</sup> USA: De-rate capacity by 4% for every 1000 ft [305 m] over 2000 ft [610 m].



At elevations greater than 2000 feet, the combustion of the appliance must be checked with a calibrated combustion analyzer to ensure safe and reliable operation. Consult Section 7.0 for instructions on adjusting the input to provide proper operation. **It is the *Installers responsibility* to check the combustion, and to adjust the combustion in accordance with Section 7.0.** Failure to follow these instructions may result in property damage, serious injury, or death.

## 2.0 BOILER LOCATION

In all cases, the Trinity Ti must be installed indoors in a dry location where the ambient temperature must be maintained above freezing and below 100°F [38°C]. Gas components must be protected from dripping, spraying water, or rain during operation and servicing. Consider the proximity of system piping, gas and electrical supply, condensate disposal drain, and proximity to vent termination when determining the best appliance location.



Water or flood damaged components must be replaced immediately with new factory-approved components as failure to do so may result in fire, serious injury, or death.

### Appliance Area Ventilation Air Openings

If appliance area clearances are less than the recommended clearances specified in Table 2-1, the appliance area must be ventilated. Each ventilation air opening must meet the minimum requirements of 1 in<sup>2</sup> per 1000 Btu/hr, but not less than 100in<sup>2</sup>. The lower ventilation opening must be located within 6” of the floor while the upper opening must be located 6” from the top of the space.

### Closet Installations

For closet installations, it is necessary to provide two ventilation air openings, each providing a minimum area equal to 1 in<sup>2</sup> per 1000 Btu/hr, but not less than 100 in<sup>2</sup> and within 6” of the top and bottom of the closet door. All Vent and Air-Intake piping within the closet must be CPVC for both Canada and the US. See Table 2.1 for Minimum and Recommended Clearances.

### Alcove Installations

Alcove installations have the same minimum clearances as closet installations, except the front must be completely open to the room at a distance no greater than 18” [457 mm] from the front of the appliance and the room is at least three (3) times the size of the alcove. Provided these conditions are met, the appliance requires no extra ventilation air openings to the space. All Vent and Air-Intake piping within the alcove must be CPVC for both Canada and the US. See Table 2-1 for Minimum and Recommended Clearances.

### Residential Garage Installations

When installed in a residential garage, mount the appliance a minimum of 18” [457 mm] above the floor. Locate or protect the appliance so it cannot be damaged by a moving vehicle. Check with your local authorities for other possible regulations pertaining to the installation of an appliance in a garage.

**Table 2-1 Minimum Clearances for Installation and Service**

Model No.	Clearances	Dimensions - inches [mm]					
		Front	Top	Sides	Bottom	Rear	Flue/Water Pipe
Trinity Ti100-200	Minimum	24 [610] <sup>1</sup>	12 [305]	12 [305]	9 [229]	0	1 [25]
	Recommended	24 [610]	24 [610]	24 [610] <sup>2</sup>	9 [229]	0	1 [25]

**Notes:**  
<sup>1</sup> 6” if surface is removable allowing 24” [610 mm] clearance (i.e. closet installation). See “Appliance Ventilation Air Openings” above.  
<sup>2</sup> Clearances can be as low as 12” [305 mm] on one side if clearance on the other side is 24” [610 mm].

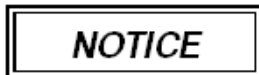

The appliance area is considered to be a closet or alcove if the area does not provide the recommended clearances listed in Table 2-1. See special instructions under Closet and Alcove Installations.

### 3.0 VENTING

The Trinity Ti is a “Direct Vent” appliance requiring a “Special Venting System” designed for pressurized venting. Both the Vent and Air-Intake piping must be piped to the outdoors, using the vent material and rules outlined in this section. Under no conditions may this unit vent gases into a masonry chimney, unless it is vacant, and utilizes the approved venting material and rules described in this section. Installations must comply with the National Fuel Gas Code, ANSI Z223.1 (U.S.) or CSA B149.1 (Canada) and local requirements.



Vent and Air-Intake to be piped separately. The Trinity Ti cannot share a common vent or air-intake with multiple appliances. Failure to comply will result in serious injury or death.

#### Combustion Air-Intake Contamination

Be careful not to locate the Air-Intake termination in an area where contaminants can be drawn in and used for combustion. Combustion air containing dust, debris or air-borne contaminants will drastically increase the required maintenance and may cause a corrosive reaction in the Heat Exchanger which could result in premature failure, fire, serious injury, or death. See Table 3-1 for a list of areas to avoid when terminating air-intake piping:

**Table 3-1 Corrosive Products and Contaminant Sources**

Products to Avoid	Contaminated Sources to Avoid
Antistatic fabric softeners, bleaches, detergents, cleaners	Laundry facilities
Perchloroethylene (PCE), hydrocarbon based cleaners	Dry cleaning facilities
Chemical fertilizer, herbicides/pesticides, dust, methane gas	Farms or areas with livestock and manure
Paint or varnish removers, cements or glues, sawdust	Wood working or furniture refinishing shops
Water chlorination chemicals (chloride, fluoride)	Swimming pools, hot tubs
Solvents, cutting oils, fiberglass, cleaning solvents	Auto body or metal working shops
Refrigerant charge with CFC or HCFC	Refrigerant repair shops
Permanent wave solutions	Beauty shops
Fixer, hydrochloric acid (muriatic acid), bromide, iodine	Photo labs, chemical / plastics processing plants
Calcium Chloride	De-Icing / Ice Melters
Cement powder, crack fill dust, cellulose, fiber based insulation	Concrete plant or construction site



Do not store or use gasoline or other flammable vapors and liquids in the vicinity of this or any other appliance. Failure to follow instructions may result in serious injury or death.

#### Flammable Solvents and Plastic Piping

Due to the extremely flammable characteristics of most glues, cements, solvents and primers used in the process of joining plastic vent and air-inlet pipe, explosive solvent vapors must be evacuated from the vent and air-intake prior to start-up. Avoid using excess cement or primer that may lead to pooling inside the pipe assembly. Freshly assembled piping should be allowed to cure for a minimum of 8 hours before applying power to the gas fired appliance. Refer to **Mandatory Pre-commissioning Procedure for Plastic Venting** in this section.



**Flammable Cements and Primers** – It is the installers’ responsibility to familiarize themselves with the hazards associated with explosive solvents and to take all precautions to reduce these risks. Failure to follow these instructions can cause explosions, property damage, injury or death.

## Attaching Vent Piping to Boiler

- It is extremely important for the intake and exhaust piping to be adapted to the appropriate size immediately upon exiting the boiler cabinet. Trinity Ti's come with a 3"x1-1/2" PVC adapter to be used to connect immediately to the air intake port of the boiler.
- The Trinity Ti exhaust connection is 3" male PVC, use approved cement to connect to venting system.
- Check the flue outlet gasket for proper insertion and sealing prior to and after attaching the venting.
- Ensure the venting system does not apply a load or stain on the flue outlet of the boiler (recommend using two elbows to create a "swing joint" as shown above).



When connecting the field provided 3" coupling to the boiler flue outlet connection, ensure the proper cement is used. For applications using CPVC venting, PVC to CPVC transition cement must be used. Failure to follow these instructions may result in property damage, personal injury or loss of life.

It is recommended that two elbows be used, so that the slope of the horizontal exhaust vent does not affect the vertical plumb of the pipe connected to the boiler. Slope all horizontal indoor exhaust venting 1/4" to 1/2" per linear foot.

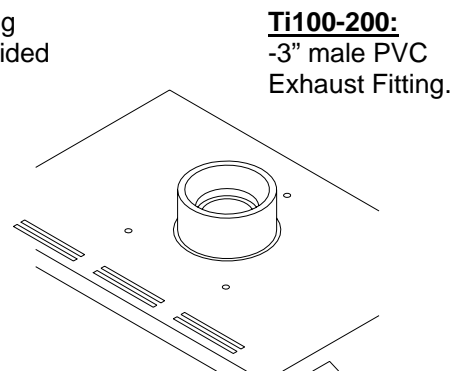
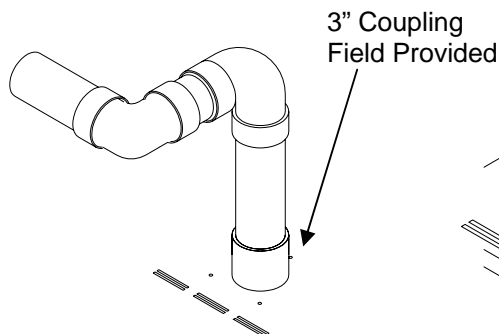

In Canada, the first **3 ft (915 mm)** of vent piping must be readily accessible for inspection.

## Vent/Air-Intake Pipe Material

Table 3-2 Acceptable Vent and Air-Intake Pipe Material

Items <sup>1</sup>	Materials <sup>2,3</sup>	Installation Standards		
		United States	Canada <sup>4</sup>	
Vent Pipe and Fittings	PVC - DWV	ANSI/ASTM D2265	All venting material in Canada must be <b>ULC S636 approved</b> . See Note 4 below for appropriate temperature applications.	All plastic Vent materials installed on gas fired appliances in CAN/US must meet the Standards listed in Table 3-2. Failure to comply could result in fire, serious injury or death.
	PVC Schedule 40	ANSI/ASTM D1785		
	CPVC Schedule 40	ANSI/ASTM F441		
Pipe Cement	PVC	ANSI/ASTM D2564		
	CPVC	ANSI/ASTM F493		
Primers	PVC / CPVC	ANSI/ASTM F656		

**Notes:**

<sup>1</sup> Refer to Table 3-2 for Allowable Vent and Air-Intake Pipe Sizes and Lengths.

<sup>2</sup> Closet/alcove installations in US and Canada require approved **CPVC** vent pipe, fittings, cements, and primers.

<sup>3</sup> The Air-Intake does not require high temperature pipe material. Check applicable local codes for acceptable materials.

<sup>4</sup> ULC S636 PVC is approved for flue gas temperatures up to 149°F (65°C) and must only be used for low temperature applications. High temperature applications requiring appliance supply water temperatures greater than 140°F (60°C) must use ULC S636 approved CPVC.

## Mandatory Pre-commissioning Procedure for Plastic Venting



Do not apply power to the appliance prior to Step 4 in the Mandatory Pre-commissioning Procedure for Plastic Venting.

- Working with the power turned off to the appliance, completely install the vent and air intake system, securely cementing joints together. If possible, allow primers/cements to cure for 8 hours before firing the burner. If curing time is less than 8 hours, proceed with Steps 2 through 6.
- Maintain the appliance gas supply shut-off valve in the off position.
- Disconnect electrical leads to the Hot Surface. Ensure the cables are placed in a fashion where they will not arc to ground or other conductor.
- Turn power on to the appliance and apply a heat demand.
- Allow for 3 complete trials for ignition, consisting of pre and post purge of the combustion blower, until an ignition lockout occurs. Repeat the process two more times (i.e. 9 complete ignition sequences in total).
- Turn power off and reconnect the electrical leads to the Igniter.

### Vent/Air-Intake Pipe Length Determination

Use Table 3-3 to determine the maximum pipe length that can be used. The table calculates sweep, 90° elbows, and 45° elbows at 5 equivalent feet [1.52 m] each. Allowable equivalent pipe lengths for vent and air-intake pipes are shown separately for Natural Gas and LP. **Example:** A Ti200 can be installed with 105 equivalent feet [32 m] of air-intake piping and 105 equivalent feet [32 m] of vent piping when operating with Natural Gas.

**Table 3-3 Allowable Vent and Air-Intake Pipe Size and Lengths**

Model No.	Pipe Size	Gas	Length ft. [m]	Number of Elbows (90's or 45's) and Equivalent Feet [Meters]								
				1	2	3	4	5	6	7	8	9
Trinity Ti150 Trinity Ti200	3"	Natural	105 [32]	100 [30.5]	95 [28.9]	90 [27.4]	85 [25.9]	80 [24.4]	75 [22.9]	70 [21.3]	65 [19.8]	60 [18.3]
	3"	LP	50 [15.2]	45 [13.7]	40 [12.2]	35 [10.7]	30 [9.1]	25 [7.6]	20 [6.1]	15 [4.6]	10 [3.0]	5 [1.5]
Trinity Ti100	3"	NG/LP	105 [32]	100 [30.5]	95 [28.9]	90 [27.4]	85 [25.9]	80 [24.4]	75 [22.9]	70 [21.3]	65 [19.8]	60 [18.3]

The length of one vent pipe (intake or exhaust) may not exceed the length of the other vent pipe by more than 20 equivalent feet (6.1 m). Length calculations need not include the three 90° elbows of the exterior vent piping (two outlet, one inlet).

### Venting Configurations

#### Two-Pipe Vent Termination

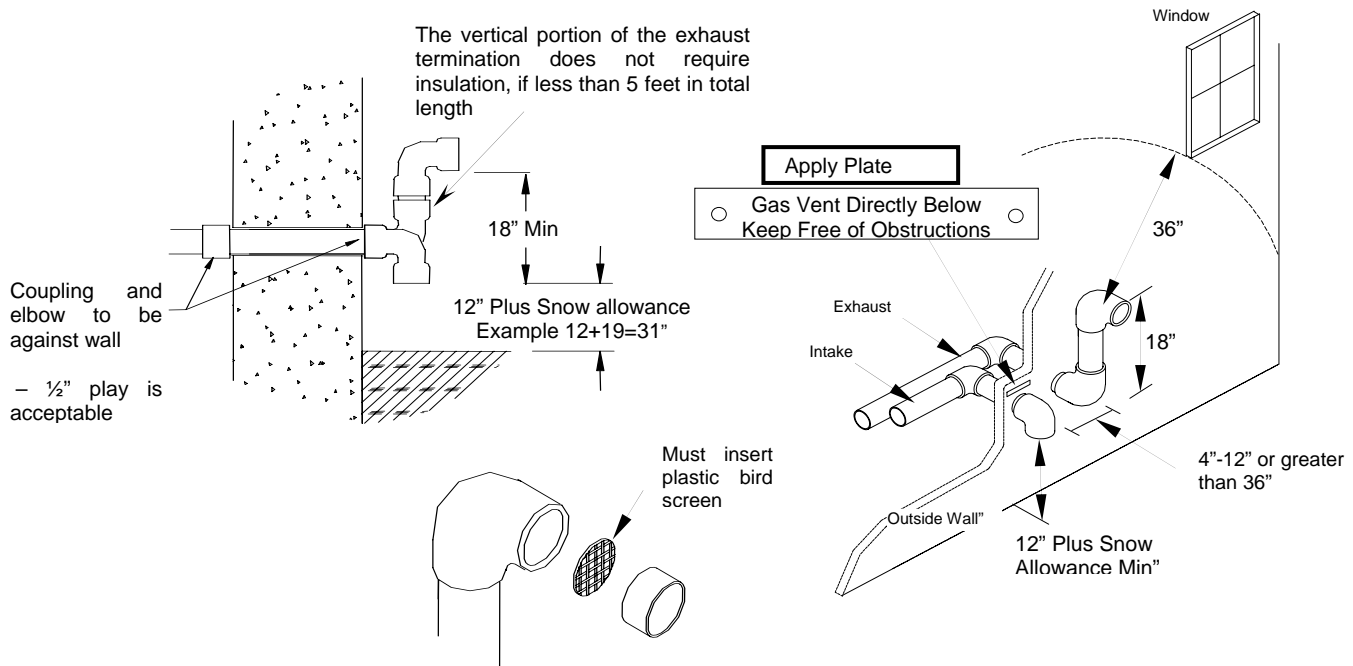

### Concentric Vent Termination Kit - United States

- Use NTI part number 82666 (York part number 1CT0303). **Kits no longer approved for use in Canada.**
- Optional for Trinity models Ti100-200 only (not for use with Lx400).
- Instructions included with vent terminal contain more detailed assembly and installation instructions.
- Clearance requirements in this manual supersede those of the instructions included with the vent terminal.
- Terminal **MUST** be cemented together during installation.

### Concentric Vent Termination Kit - Canada

- Use IPEX part number 196006 (Concentric Kit) and 196051 (Vent Screen), certified to ULC S636. Use of this material is subject to approval by local authorities. **Kit 82666/1CT0303 no longer approved for Canada.**
- Optional for Trinity models Ti100-200 only (not for use with Lx400).
- Instructions included with termination kits contain more detailed assembly and installation instructions.
- Clearance requirements in this manual supersede those of the instructions included with the vent terminal.

NTI does not stock System 636 PVC Concentric Vent Termination Kits as they are readily available from IPEX via Canadian wholesalers. Canadian customers wanting more information on System 636 Concentric Vent Kits or wholesaler locations can contact IPEX directly at 1-866-473-9462 (toll free in Canada) or [www.ipexinc.com](http://www.ipexinc.com).

**PVC In Canada** - Safety authorities in some jurisdictions are not allowing PVC venting materials with appliances of any kind, even if System 636 certified. Check with the local safety inspector to verify compliance prior to installing a PVC Concentric Vent Kit with a Trinity Ti boiler.

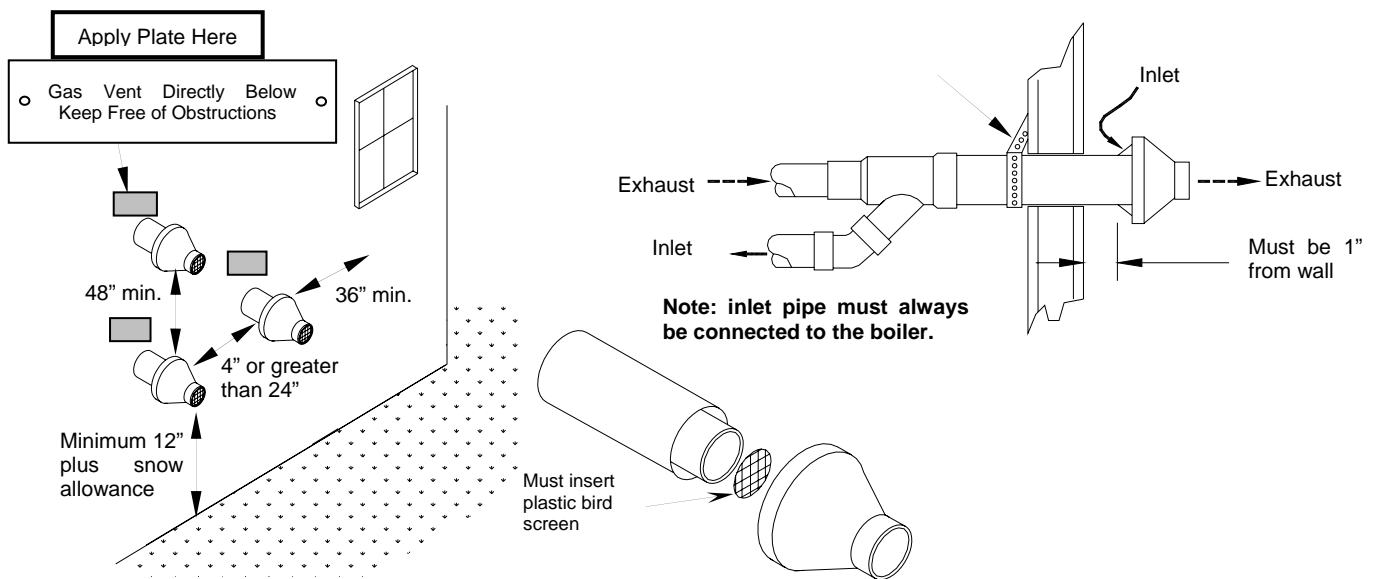

## Roof Venting

It is permissible to run vent pipe through an existing chimney as long as:

- 1) The chimney is not being used by any other appliance.
- 2) Flue gases don't enter the vacant chimney.
- 3) Only Trinity certified venting materials are used, see Table 3-2.
- 4) Vent lengths are within the maximums specified.

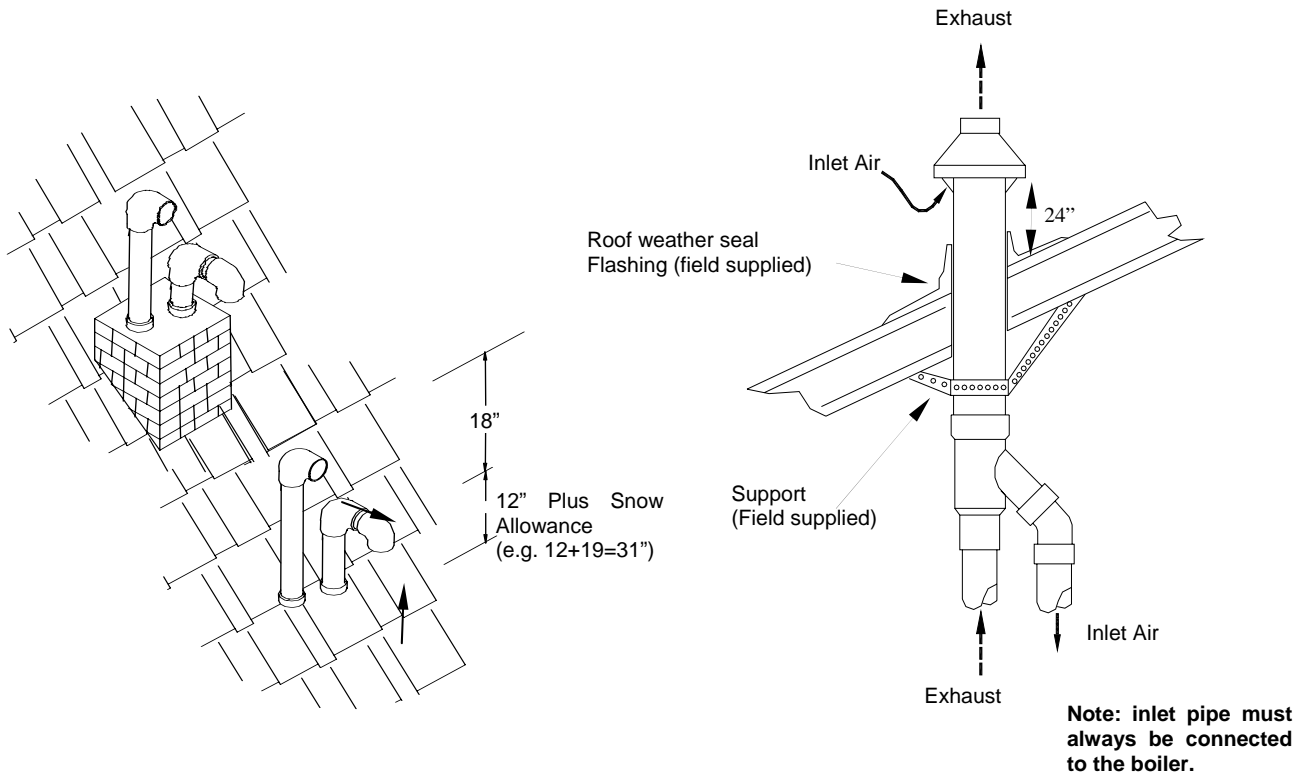

## Venting Rules and Guidelines

1. It is highly recommended that the vent terminal be located where it will not be exposed to normal prevailing winds.
2. Air for combustion must be drawn from outdoors from an area free of dust and contaminants. Combustion air containing chemicals such as chloride, fluoride, bromine or iodine, will cause corrosion damage of the heat exchanger voiding your NTI warranty. Avoid drawing combustion air from the vicinity of swimming pools, laundry facilities, workshops, or other areas where the air may contain chemicals or dust.
3. The exhaust must be a minimum of 18" above the air inlet, and the air inlet must always be a minimum of 12" plus snow allowance above any surface that will support snow. (Two feet plus snow allowance is highly recommended). Consult your weather office, for the maximum typical snowfall for your region. Example: New Brunswick Canada the typical maximum snowfall is 19", Thus in figures of Section 3.3, the inlet must be  $(12''+19'') = 31''$  off the ground, the exhaust must be  $(31''+18'') = 49''$ .
4. The horizontal distance between the inlet and exhaust must be a minimum of 4" center to center. If the horizontal distance between the inlet and exhaust is more than 12", increase the vertical separation by the same amount. Example: If horizontal separation is 24", a minimum vertical separation of 30" is required  $(24''-12''=12'')$ , so increase minimum vertical separation by 12",  $(18''+12''=30'')$ . If horizontal distance is greater than 6', no additional vertical spacing is required. Vertical separation is never required to be greater than 36".
5. Under normal operating conditions this appliance will produce a plume of white gases, and should be taken into consideration when selecting an adequate location. A 3' diameter stainless, plastic, or vinyl shield can be used to flash the exterior of the residence.
6. Elbows on outside of wall must be no greater than 1/2" away from the wall.
7. All indoor exhaust piping must be on a slope back to the boiler a minimum of 1/4" per linear foot of vent. For applications where excessive condensation is possible 1/2" per linear foot is recommended.
8. Exhaust vent pipe can be secured to the wall for more rigidity.
9. In all roof applications the discharge must point away from the pitch of the roof.
10. Install adequate flashing where the pipe enters the roof, to prevent water leakage.
11. Install and seal a rain cap over existing chimney openings, in vacant chimney applications.
12. For installations that exit the wall below grade. Excavate site as shown in figure, to a point below where the pipes are to exit. Ensure that the wall is fully sealed where the pipes penetrate the wall. The vent piping **MUST** be secured to the side of the building above grade, as shown, to provide rigidity. NTI Provides a mounting bracket PN. 82075 for securing the exhaust pipes. Ensure that the vent clearances are maintained (Inlet minimum 12" plus snow allowance from grade, exhaust outlet 18" minimum above inlet)
13. Install the vent screens provided into both the inlet and exhaust vent terminal elbows. The screen must be on the outside of the last elbow. Install the screen into the female opening of the elbow. Then cut a small piece of pipe to sandwich the screen into the elbow. NOTE be sure that the small piece of pipe cut, does not extend past the end of the elbow. Two screens are provided in the package.
14. It is extremely important that the intake and exhaust piping be adapted to the appropriate size immediately upon exiting the boiler cabinet.
15. All interior vent pipe shall be supported a minimum of every 36".
16. Install the warning plate "Gas Vent Directly Below" 4 feet above the location of the air inlet pipe, so it is visible from at least eight (8) feet away.

**Installing Venting Below Grade**

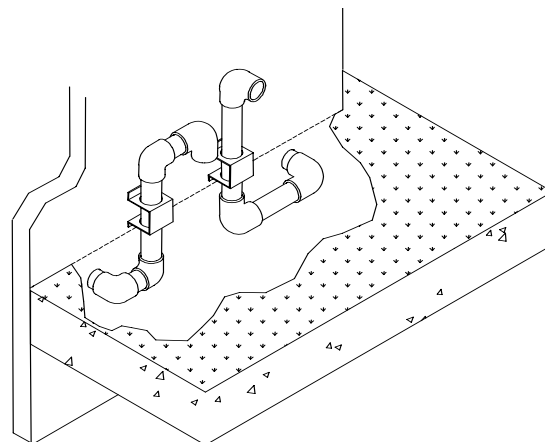

## Venting Clearances

### NOTICE

The following are code restrictions for the location of the Flue gas vent terminal. Compliance doesn't insure a satisfactory installation; good common sense must also be applied.

#### The exhaust vent termination shall not terminate:

1. Directly above a paved sidewalk or a paved driveway that is located between two buildings, and that serves both buildings;
2. Less than 7 feet above grade where located adjacent to a paved walkway or driveway located on public property.
3. Within 3' (three feet) of a window or door that can be opened, or non-mechanical air supply inlet to any building.
4. Within 6' of a mechanical air supply inlet to any building, or roof eave containing soffit openings.
5. Above a meter/regulator assembly within 3' horizontally of the vertical centerline of the regulator.
6. Within 3' horizontally of any gas service regulator vent outlet up to a height of 15'.
7. Less than 30" plus snow allowance above grade, or any surface that will support snow, ice, or debris. The exhaust must be a minimum of 18" above the air inlet, and the air inlet must always be a minimum of 12" plus snow allowance above any surface that will support snow. (Two feet plus snow allowance is highly recommended). Consult your weather office, for the maximum typical snowfall for your region.
8. Underneath a wooden verandah, porch, or deck.
9. Underneath cement verandah, porch, or deck, unless both ends are open and the exhaust pipe is installed at least 24" under the deck floor.
10. So situated that the flue gases are directed towards brickwork, siding, or other construction, in such a manner that may cause damage from heat or condensate from the flue gases.
11. Less than 3' from an inside corner of an L-shaped structure (including walls and fences).

## Outdoor Horizontal Venting

Vent piping outside the Building is permitted under the following conditions:

1. The maximum length outside the building is 20 feet. (Outdoor length must be included in the overall vent length calculation.)
2. Only 3" pipe can be used.
3. All normal termination clearances are maintained.
4. All exterior exhaust vent pipes are insulated with 3.5"-ID, 1/2"-thick **Closed Cell Foamed Polyolefin Tubing** i.e., "Tundra Seal Plus" or equivalent.
5. The pipe is supported every 24"
6. The exhaust and inlet are sloped back to the boiler 1/2" elevation for every foot.

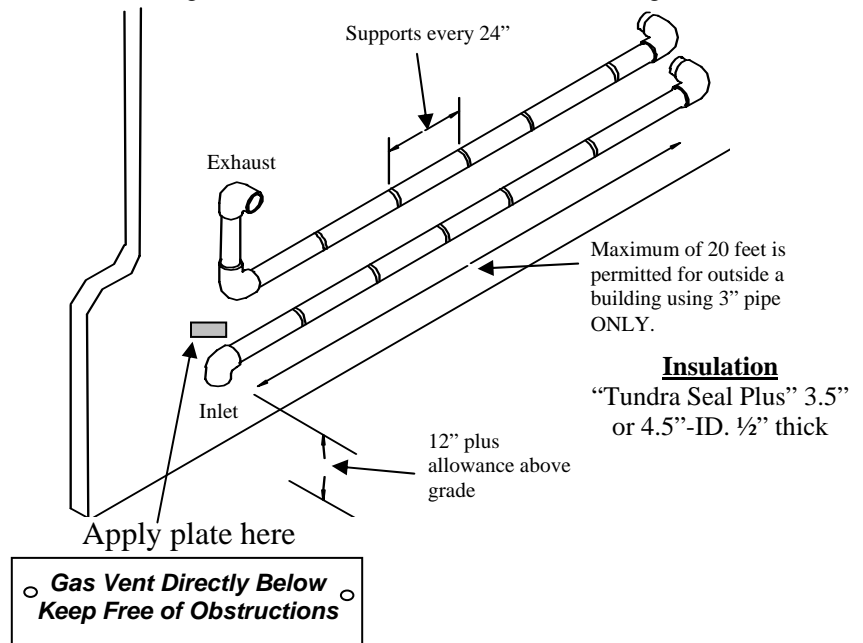

## 4.0 CONDENSATE DRAIN

This unit produces water as a product of combustion. Much of this water condenses on the heat exchanger and in the venting system. All exhaust piping must be on a slope back to the boiler  $\frac{1}{4}$ " per linear foot of vent. Steps must be taken to ensure that condensate does not collect in the venting system. Condensate must be drained from the boiler into a household drain.



**DANGER** Failure to properly connect the condensate trap and drain will cause combustion gases to enter the room resulting in property damage, serious injury or death.

**Note: check with your municipality, or local gas company to determine if disposal of combustion condensate is permitted. In the State of Massachusetts the condensate must be neutralized prior to entering a drain.**

The following are important notes that must be taken into consideration when constructing the condensate system:

- **DO NOT** run condensate line outside. A frozen or blocked drain will cause the condensate to fill the combustion chamber. This will result in a no heat condition, as the unit will shut down, and damage to the flame sensor, and components can occur.
- **NEVER** use copper, steel, or galvanized piping in the construction of the condensate system (condensate is very corrosive and will rot most metals).
- When a condensate pump is used or required, select a pump that is designed for residential furnaces.



**DANGER** If the condensate drain becomes blocked resulting in condensate backing-up into the heat exchanger, the combustion chamber must be inspected and cleaned and internal refractory must be replaced; see "Combustion Chamber Cleaning" in Section 16.0 for further details. Failure to follow these instructions will result in dangerous boiler operation resulting in property damage, fire or loss of life.



**WARNING** The condensate drain kit supplied with each boiler is susceptible to flooding if the drain hose exiting the kit is lengthened or inserted into a drain. If additional length is required, do not use the drain kit provided, instead fabricate a 15" trap using tubing suitable for condensate disposal.

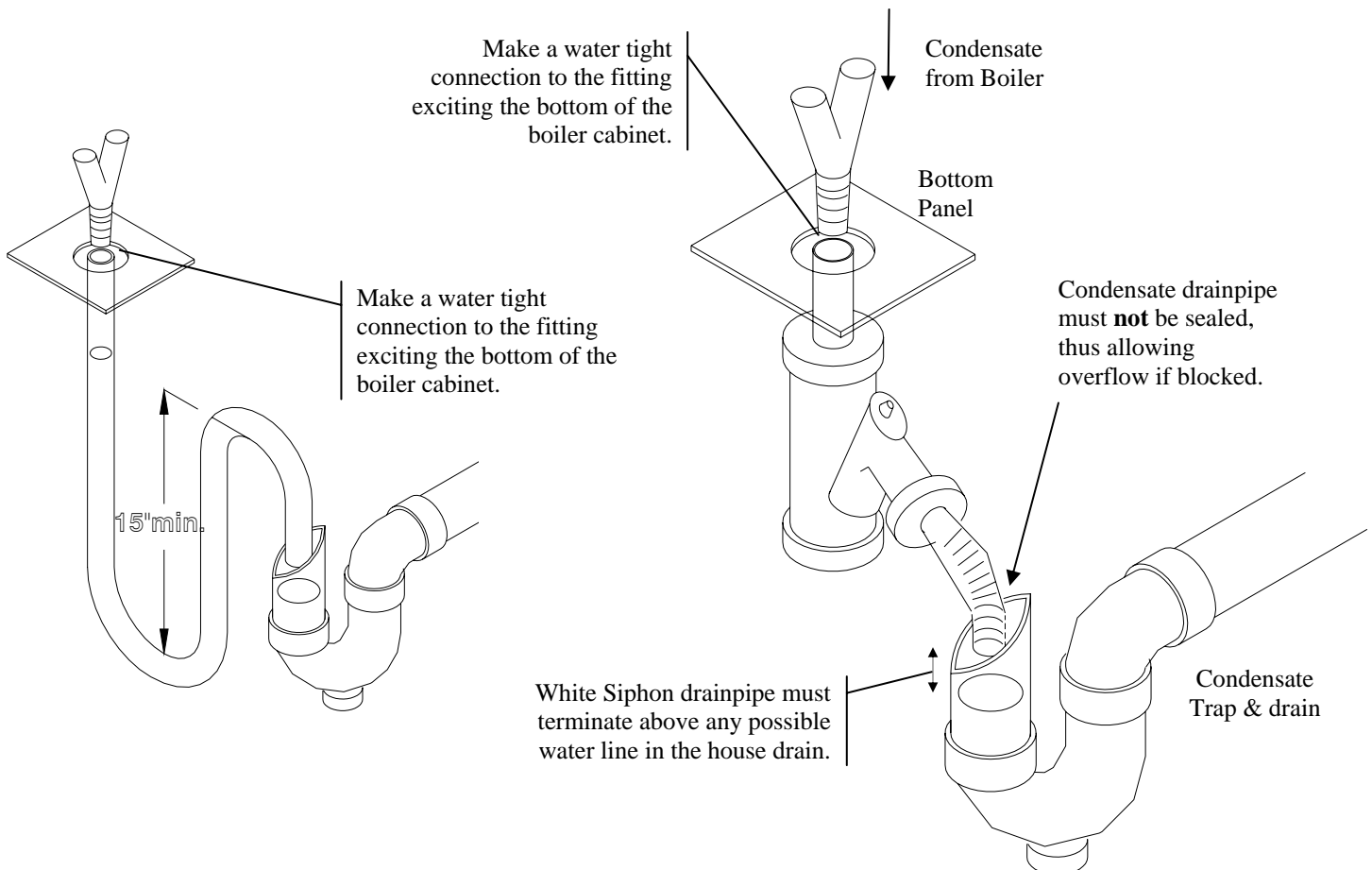

## 5.0 INSTALLING GAS PIPING



The Trinity Ti is factory equipped to operate with Natural Gas, the installation of a conversion kit is required prior to operating with Propane Gas. The Natural to LP Conversion Kit must be installed prior to installing the gas piping to the appliance. Failure to properly convert the unit to operate with Propane may result in property damage, serious injury or death.



Liquefied Petroleum (LP) propane gas is heavier than air; therefore, it is imperative that your appliance is not installed in a pit or similar location that will permit heavier than air gas to collect. Check with Local Codes as they may require appliances fueled with LP gas be provided with an approved means of removing unburned gases from the room. Failure to follow these instructions may result in serious injury or death.

### Installation

Refer to the current **National Fuel Gas Code ANSI Z223.1/NFPA 54 or CAN/CGA B149.1** installation codes, and local codes for gas piping requirements and sizing. Pipe size running to the unit depends on:

- Length of pipe.
- Number of fittings.
- Type of gas.
- Maximum input requirement of all gas appliances in the residence.

### Ensure that:

- The gas line connection to the appliance does not apply any weight to the gas valve. NTI recommends using approved flexible gas piping (if acceptable by local codes) to connect the appliance to the gas supply (See Figure 5-1 for details).
- You plan the installation so that the piping does not interfere with the vent pipe, or the removal of the valve, burner, and serviceable components.
- The Appliance shall be installed such that the gas ignition system components are protected from water (dripping, spraying, rain etc.) during installation and servicing.
- The gas piping is large enough for all the appliances in the home. No appreciable drop in line pressure should occur when any unit (or combination of units) lights or runs. Use common gas-line sizing practices.
- Always use a pipe-threading compound that is resistant to propane (LP) gas solvent action. Apply sparingly to all male threads, starting at two threads from the end. Over doping or applying dope to the female end, can result in a blocked gas line.
- **DO NOT TIGHTEN FITTINGS WITHOUT SUPPORTING THE GAS VALVE** as damage to the valve or blower motor can occur.
- Install a manual "Equipment Shut-Off Valve" as shown in Figure 5-1. Valve must be listed by a nationally recognized testing lab.
- The gas line piping can safely be removed from the appliance for servicing, by strategically placing the gas line shutoff and union; see example in Figure 5-1.
- All gas piping, including gas components in the appliance, are checked for leaks using a "Bubble Test", prior to operating the appliance.



Strain on the gas valve and fittings may result in vibration, premature component failure and leakage and may result in a fire, explosion, property damage, serious injury or death.



Flexible gas piping cannot be used within the appliance cabinet and cannot pass through the cabinet wall, use rigid piping as shown in Figure 5-1. Failure to follow these instructions may result in fire, property damage, serious injury or death.



Do not use an open flame to test for gas leaks. Failure to follow these instructions may result in fire, property damage, serious injury or death.



When performing a pressure test on the gas line piping, be sure the appliance is disconnected or isolated if the test pressure is expected to exceed 1/2 PSI (14" w.c.), as damage to the valve could occur resulting in fire, property damage, serious injury or death.

Figure 5-1 Gas Connection

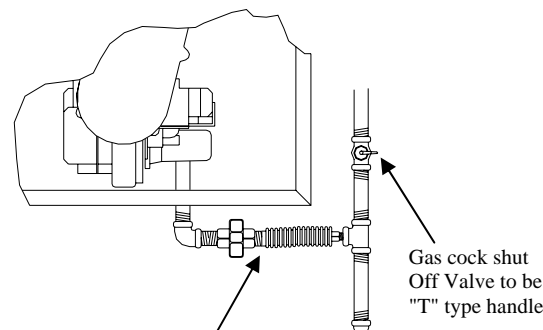

It is highly recommended to use flexible gas pipe, the gas valve and blower cannot support the weight of piping. If piping is used, ensure that the valve supports **NO WEIGHT**

## 6.0 LIGHTING THE APPLIANCE



Before Start-up refer to **Mandatory Pre-commissioning Procedure for Plastic Venting** in Section 3.0. Failure to follow these instructions can result in explosions, injury or death.



Prior to turning the gas supply on and lighting the appliance, ensure all aspects of the installation are complete and in conformance with the instructions provided in this manual, including the Vent/Air-Intake, Condensate Drain, and System Water Piping. Failure to precisely follow these instructions will cause a fire or explosion resulting in property damage, serious injury or death.



Do not store or use gasoline or other flammable vapors & liquids in the vicinity of this or any other appliance. Failure to follow instructions could result in explosion causing property damage, serious injury or death.



If you do not follow these instructions exactly, a fire or explosion may result causing property damage, serious injury or death.



Should overheating occur or the gas supply fail to shut off, turn off the manual gas control valve to the appliance. Failure to follow instructions could result in explosion causing property damage, serious injury or death.

### FOR YOUR SAFETY, READ BEFORE OPERATING

- A) This appliance does not have a pilot. It is equipped with an ignition device which automatically lights the burner. Do not try to light the burner by hand.
- B) **BEFORE OPERATING** smell all around the appliance area for gas. Be sure to smell next to the floor because some gas is heavier than air and will settle on the floor.  
**WHAT TO DO IF YOU SMELL GAS:**
  - Do not try to light any appliance.
  - Do not touch any electric switch.
  - Do not use any phone in your building.
  - Immediately call your gas supplier from a neighbor's phone. Follow the gas supplier's instructions.
  - If you cannot reach your gas supplier, call the fire department.
- C) Use only your hand to push in or turn the gas control knob. Never use tools. If the knob will not push in or turn by hand, don't try to repair it, call a qualified service technician. Force or attempted repair may result in a fire or explosion.
- D) Do not use this appliance if any part has been under water. Immediately call a qualified service technician to inspect the appliance and to replace any part of the control system and any gas control which has been under water.

### OPERATING INSTRUCTIONS

1. **STOP!** Read the safety information above very carefully.
2. Set the thermostat to lowest setting. Turn off all electric power to the appliance.
3. This appliance does not have a pilot. It is equipped with an ignition device which automatically lights the burner. Do not try to light the burner by hand.
4. Turn the manual gas valve to the OFF position. Remove front access panel.
5. Wait five (5) minutes to clear out any gas. Then smell for gas, including near the floor. If you smell gas, **STOP!** Follow "B" in the safety information above. If you don't smell gas, go to the next step.
6. Turn the manual gas valve ON. Wait an additional five (5) minutes smelling for gas.
7. Replace the front access panel.
8. Set thermostat to highest setting. Turn on all electric power to the appliance.
9. Ignition sequence is automatic. Combustion will occur after a brief fan purge.
10. If ignition does not occur, follow the instructions "To Turn Off Gas To Appliance" and call your service technician or gas supplier.

### TO TURN OFF GAS TO THE APPLIANCE

1. **STOP!** Read the safety information above very carefully.
2. Turn off all electric power to the appliance
3. Turn the manual gas valve to the OFF position



The initial lighting of the appliance must be performed by a licensed Gas Technician. Failure to follow instructions may result in property damage, serious injury or death.

- Ensure the appliance is wired in accordance with this manual.
- Ensure the gas shut-off valve is turned on, and that the gas system has been fully tested for leaks.
- Ensure the system is completely filled with water, and that ALL the air is purged out.



Allow primers/cements to cure for 8 hours prior to Start-up. If curing time is less than 8 hours, first perform Steps 2 through 6 of **Mandatory Pre-commissioning Procedure for Plastic Venting** in Section 3.0. Failure to follow these instructions can result in explosion, serious injury or death.

### Initial Start-Up

1. Turn on power to the Trinity Ti and turn-up the Thermostat(s). The appliance should run through a purge, and combustion should occur. (The control system has a built in ignition retry, allowing the system to try at least three times, before locking-out.)
2. With the unit operating at full capacity, verify that the gas line pressure is 4-10.5 inches w.c. for Natural gas, and 9-13 inches w.c. for Propane (See Section 7.0 for details).
3. Using an appropriate Oxygen or Carbon Dioxide analyzer, take a sample of the flue gas. The sample must fall within the acceptable ranges for Carbon Dioxide, which is 8.5% - 9.5% for Natural gas, and 9.5%-10.5% for propane (See Section 7.0 for details). Notice: unit shall be operating at maximum firing rate during the combustion test.
4. Perform at least three lights in succession to ensure proper operation.
5. After the three successive lights, unplug the flame probe, and allow the unit to cycle again. Ensure that it tries to light, and locks out on safety reset. Once you have successfully activated the flame safety system, replace the wire on the flame sensor, and reconfirm proper lighting.



If the unit fails to light consistently and smoothly, contact NTI for assistance at 1-800-688-2575. Never allow the appliance to continue to operate if the ignition or operation of the burner is rough or erratic. Failure to follow these instructions could result in serious injury or death.

### Re-lighting Unit

1. Stop and read these instructions very carefully.
2. Set the thermostat to the lowest setting, and then turn off all power to the appliance.
3. This appliance does not have a pilot. It is equipped with an ignition device that automatically lights the burner. Do not try to light the burner by hand.
4. Turn the gas shut-off valve to the off position, and then remove the front cover.
5. Wait five (5) minutes to clear out any gas. Then check for gas, including near the floor. If you smell gas “Stop” and follow “B” above. If you don’t detect any gas proceed to the next step.
6. Turn the gas shut-off valve to the on position, wait an addition five (5) minutes and check for gas.
7. Replace the front cover.
8. Set the thermostat to the highest setting, and then turn on all power to the appliance.
9. Ignition sequence is automatic, combustion will occur after a brief fan purge. Ignition will retry 3 times.
10. If ignition does not occur, “Turn off the gas and electricity to the appliance” and contact a professional service technician, or gas supplier.

### Turning Off The Appliance

1. Set the thermostat to the lowest setting, and then turn off all power to the appliance.
2. Turn the gas shut-off valve to the off position.

## 7.0 GAS VALVE AND BURNER SET-UP



Set-up of the Trinity Ti gas valve must be performed by a licensed Gas Technician. Failure to perform the set-up correctly may result in incorrect operation, component failure, property damage, serious injury or death.

### Gas Line Pressure

The appliance gas valve is equipped with a line pressure test port; see Figures 7-1. Use the following procedure to measure the gas line pressure to the appliance to ensure it falls within the range given in Table 7-1:

1. Turn the supply of gas to the appliance off.
2. Open the bleed screw of the line pressure test port approximately 1-1/2 turns. This port is directly connected to the gas line feeding the appliance.
3. Force 1/4" ID tubing over the housing of the line pressure test port; install the other end of the tubing to an appropriate line pressure test gauge or manometer. Ensure both ends of the tubing make a tight connection.
4. Open the supply of gas to the appliance and check for gas leaks.
5. Observe the line pressure under static conditions and compare it to Table 7-1. The pressure will be greatest under static conditions.
6. With all other gas appliances in the application running, operate the burner to the maximum firing rate (See Table 7-2) and compare the observed line pressure with Table 7-1. The pressure will be lowest during the maximum flow of gas.
7. Adjust the gas line pressure to ensure the parameters in Table 7-1 are attained under all conditions. If possible adjust the line pressure to the "Nominal/Desired" value listed in Table 7-1, while the unit is operating at the maximum modulation rate, see Table 7-2.
8. Continue observing the gas line pressure until the completion of the combustion analyses, in case adjustments need to be made.
9. Upon completion of the line pressure testing, return the bleed screw of the Line Pressure Test Port to the closed position.

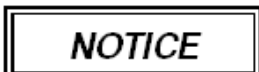

The line pressure is a function of the gas supply and is affected solely by field provided parameters such as line size and regulator settings. Under no circumstances can the appliance gas valve influence or be used to adjust the gas line pressure.



Failure to close the bleed screw of the Line Pressure Test Port will cause a severe leakage of gas, resulting in a fire or explosion causing property damage, serious injury or death.

**Table 7-1 Line Pressure and Combustion Parameters**

Gas	Line Pressure (inches wc)			CO <sub>2</sub> (%)*		CO (ppm) Max.
	Nominal/Desired	Min.	Max.	Min.	Max.	
Natural	7	4	10.5	8.5	9.5	175
Propane	11	8	13	9.5	10.5	175

\*Note: it is permissible to have higher CO<sub>2</sub> values with the burner operating at the minimum modulation rate.

**Table 7-2 Minimum and Maximum "Gas Input Values" (Modulation Rates)**

Model	Minimum Gas Input Value	Maximum Gas Input Value
Ti100	50	240
Ti150	50	240
Ti200	40	240



Never leave the unit operating while producing Carbon Monoxide (CO) concentrations in excess of 175ppm. CO concentration will be greatest with the boiler operating at the highest firing rate, therefore measure and make necessary adjustments with unit operating at the Maximum Gas Input Value, see Table 7-2. Failure to

follow this warning may result in serious injury or death.



DO NOT adjust or measure the Manifold Pressure of the appliance. Correct manifold pressure is factory set. Field adjustment could result in improper burner operation resulting in fire, explosion, property damage or death.

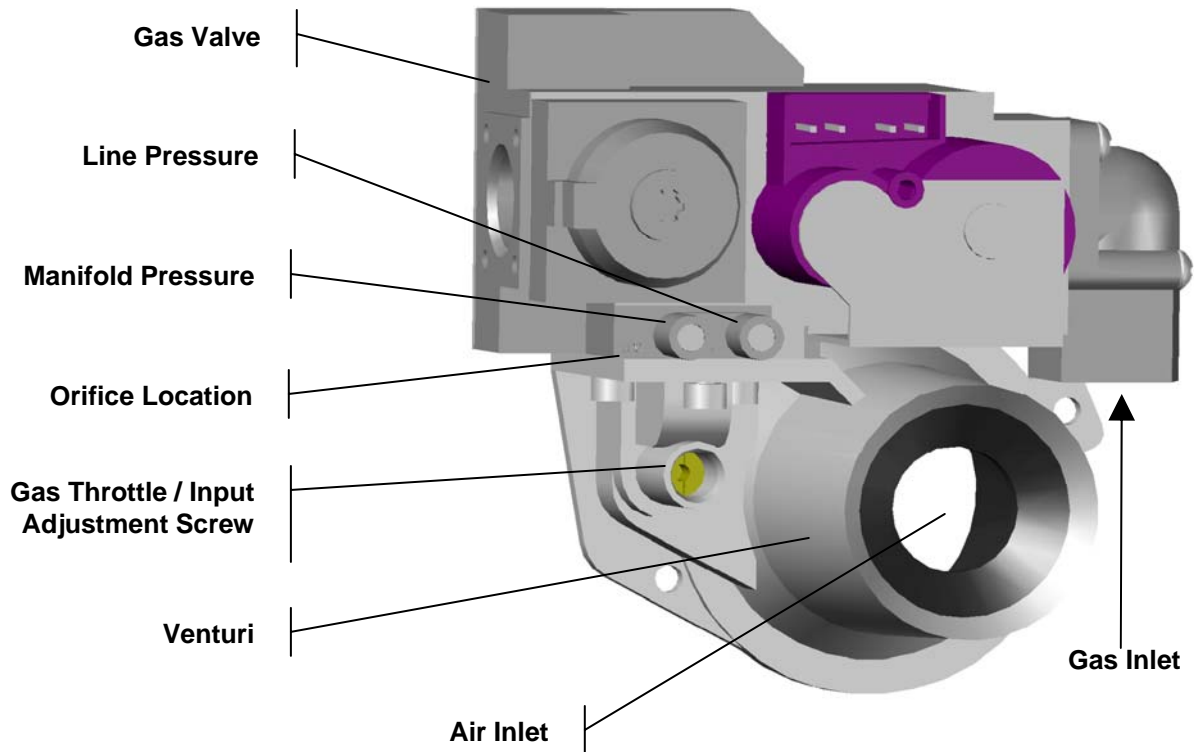

**Figure 7-1 Gas Valve Venturi Assembly**



**Adjustment**

**Input Screw Adjustments** - The appliance is equipped with a Throttle/Input Adjustment Screw, located on the Gas Valve and Venturi Assembly. The Throttle screw is used to adjust the flow of gas leaving the gas valve, entering the Venturi and hence entering the combustion air stream. By turning the adjustment screw in, clockwise, the flow of gas is reduced and the combustion becomes leaner, thus reducing the concentration of CO<sub>2</sub> in the flue gases. To increase the CO<sub>2</sub> the Throttle screw must be adjusted out, counterclockwise, thus increasing the flow of gas from the gas valve to the combustion air stream.

The Throttle/Input screw for models Ti100-200 is a multiple turn valve. Fully open to close is approximately 17 turns. Typical adjustment for Natural Gas is 0-1 full turns in or out from its factory position. Typical adjustment for LP Gas is 0-3 full turns in or out from its factory position. See Figure 7-1 for screw location.

<b><u>Throttle/Input Adjustment Screw</u></b>	
Decrease gas Turn Clockwise	
Increase gas Turn Counterclockwise	



**WARNING** Adjustments to the Throttle screw may only be made by a qualified gas technician, while using a calibrated combustion analyzer capable of measuring CO<sub>2</sub> and CO. Failure to follow these instructions may result in serious injury or death.



**WARNING** Adjustments to the Throttle screw may only be performed if the gas line pressure is maintained above minimum levels throughout the duration of the test, see Table 7-1. Failure to follow these instructions may result in serious injury or death.

**Combustion Calibration** - To calibrate burner operation, perform the following procedure using a calibrated combustion analyzer capable of measuring CO<sub>2</sub> and CO from Natural and Propane Gas burning appliances:

1. Operate the unit at the maximum modulation rate, see Table 7-2.
2. Ensure the gas line pressure is maintained within tolerance, see Table 7-1.
3. While at the maximum Gas Input Value, measure the CO<sub>2</sub> and CO; adjust as necessary, using the Throttle Screw, to be within the limits listed in Table 7-1.
4. Operate the unit at the minimum Gas Input Value (Table 7-2). Ensure the combustion remains smooth and CO<sub>2</sub> and CO remain within the limits (Table 7-1). If not, do not adjust further, contact NTI for assistance.

**Maximum Modulation Rate** – The Trinity Ti boiler is equipped with an electronic burner control that will modulate the firing rate to match the demand placed on the unit. There is no way to force the appliance to operate at the maximum modulation rate; the unit will automatically determine the modulation rate based on the water temperature and the temperature set points. To help obtain the maximum modulation rate the following steps should be taken:

1. Remove the Outdoor sensor wires from the boiler (see Figure 10-1).
2. Change the HI setting to the maximum safe water temperature that the heating system can handle (see Section 11.0).
3. Turn on all heating zones and set thermostats to their maximum setting.

**CAUTION**

Failure to reconnect the Outdoor Sensor may increase fuel consumption. Failure to return the HI setting to the heating system maximum desired working temperature may result in property damage or excessive fuel consumption.

Alternate method (DHW with Combi or Indirect Fired Water Heater):

1. Turn on several hot water fixtures
2. Set boiler LO setting to 190 (see Section 11.0)
3. If using a Combi boiler the unit will run and stay at high fire until the taps are turned off.
4. If using an indirect hot water tank, allow the tank to cool off before turning the boiler on.

**CAUTION**

Failure to return the LO setting to the desired working temperature may result in excessive fuel consumption. See Table 10-3 for recommended settings.

**Minimum Modulation Rate** – Like the maximum modulation rate, there is no way to force the Trinity to operate at the minimum modulation rate. To help obtain the minimum modulation rate follow the steps above for the maximum modulation rate, but slowly reduce the system water flow rate until the minimum modulation rate is achieved. When using the alternate method (DHW with Combi or Indirect Fired Water Heater), reduce the LO setting to the minimum value.

### Flue Gas Analysis and Adjustment

Each Trinity Ti is factory set to operate with Natural Gas, for appliances field converted to operate with Propane Gas, a flue gas analysis and adjustment is mandatory. See Table 7-1 and propane conversion instructions.

**WARNING**

Failure to perform the flue gas analysis and adjustment detailed in this section may result in erratic and unreliable burner operation, leading to reduced efficiency, increased fuel consumption, reduced component life, heat exchanger combustion deposits, and general unsafe operation. Failure to follow these instructions may result in serious injury or death.

**Analysis** – The Trinity Ti is not equipped with an integrated flue gas test port, flue gases must be sampled at the vent termination or at the condensate drain. When measuring from the termination, ensure the combustion gases are sampled from within the exhaust pipe by inserting the combustion analyzer probe several inches into the exhaust pipe. When measuring from the condensate drain, remove the condensate drain trap and insert the combustion analyzer probe into the condensate drain line while still allowing some flue gases to vent into the room. Perform the flue gas analysis and adjust the gas Throttle/Input Screw as required until CO<sub>2</sub> and CO levels are within acceptable limits, see Table 7-1. If testing is performed via the condensate drain, ensure the flue gases are checked immediately to prevent high levels of Carbon Monoxide from entering the room. Once testing is complete, re-install the condensate drain assembly and check for leaks.

**DANGER**

Failure to re-install the condensate drain will result in, property damage, serious injury or death.

## 8.0 BOILER AND HEATING SYSTEMS PIPING

The heat exchanger of the Trinity boiler is designed to attain the highest level of heat transfer in a compact design. To accomplish this, the heating water flows through a series of fin shaped tubes, designed to maximize the heat transfer area. To maintain the efficient and reliable operation of the heat exchanger, and to avoid heat exchanger failure, it is critical to ensure the rules and guidelines in this section are followed.



Failure to follow the instructions provided in this section will void the NTI warranty and may result in property damage, fire, serious injury or death.

### Boiler System Preparation

Prior to connecting plumbing to the boiler, flush the entire system to ensure it is free of sediment, flux, solder, scale, debris or other impurities that may be harmful to the system and boiler. During the assembly of the heating system, it is important to keep the inside of the piping free of any debris including construction and copper dust, sand and dirt.

For retrofits, all system piping including radiators, must be cleaned of all build-up including sludge and scale. All systems, old and new, must be cleaned to remove flux, grease and carbon residue. NTI recommends cleaning the boiler system with “Ferrox F3 Cleaner”. For retrofit applications with heavy limescale and sludge deposits, a heavier duty cleaner may be required; NTI recommends the use of “Ferrox DS-40 System Cleaner”. For information on performing the cleaning, follow the instructions included with the Ferrox DS-40 System Cleaner. See Table 8-1 for list of recommended boiler cleaning products.



Failure to rid the heating system of the contaminants listed above will void your NTI warranty and may result in premature heat exchanger failure and property damage.

**Table 8-1 Boiler System Cleaners and Corrosion Inhibitors**

Application	Ferrox Product	NTI Part #	Description
Boiler Water Treatment	F1 Protector	83448	Corrosion inhibitor.
Cleaner for new and old systems	F3 Cleaner	83449	Removes flux, grease and carbon residue.
Cleaner for Retrofits	DS-40 System Cleaner	83450	Removes heavy limescale and sludge deposits.

### Boiler Water

**Pressure** - The Trinity boiler is intended solely for use in pressurized closed loop heating systems operating with a minimum pressure of 15 PSI at the boiler outlet. To obtain the minimum system design pressure, follow the piping diagrams illustrated in this section.

**Oxygen Elimination** - This boiler may only be installed in a pressurized closed-loop heating system, free of air (oxygen) and other impurities. To avoid the presence of oxygen, ensure all of the air is removed from the system during commissioning via strategically placed adequately sized air-removal devices, located throughout the heating system. See figures in this section detailing the location of the primary air-removal device required for the boiler. Immediately repair any leaks in the system plumbing to avoid the addition of make-up water; make-up water provides a source of oxygen and minerals that may lead to heat exchanger failure. Failure to follow these instructions will result in poor performance, unnecessary wear of system components and premature failure. **NOTICE:** The Trinity Ti boiler is not approved for operation in an “open system”, thus it cannot be used for direct potable water heating or process heating of any kind.

**Water Chemistry** – The installer of the Trinity Ti boiler must consider the condition of the water in the heating system. Ensure the condition of the boiler water falls within the following parameters:

- Water hardness – between 3 and 9 Grains/gal.
- PH – between 7.5 and 9.5.

**Treatment** - Boiler water must be treated with a corrosion inhibitor. Each Trinity Ti boiler is provided with a bottle of “Ferrox F1 Protector” corrosion inhibitor, adequate to treat a 26.4 gallon (100 liter) heating system to a minimum required concentration of 0.5%. Systems with greater volume will require more inhibitor. For information on performing the treatment, follow the instructions included with the Ferrox F1 Protector. See Table 8-1 for a list of recommended boiler system cleaners and corrosion inhibitors. **IMPORTANT:** To maintain protection, the level of corrosion inhibitor must be monitored periodically for the correct concentration.

**Anti-freeze** - For systems requiring freeze protection, use only inhibited propylene glycol, specially formulated for hydronic heating systems; use of other types of antifreeze may be harmful to the system and will void the warranty. Note: the use of glycol may reduce the usable output capacity of the boiler, thus requiring the unit to be “down-fired” by limiting the maximum operating capacity and/or the maximum water temperature. NTI recommends against exceeding a 35% concentration of glycol.

## Near Boiler Plumbing

**Pressure Relief Valve** - A 30PSI Pressure Relief Valve is factory supplied with all boilers. Since all Trinity Ti boilers, excluding Ti100's and Ti150's sold in Canada (MAWP=30PSI), have a maximum operating pressure of 145PSI, a pressure relief valve with a higher discharge pressure rating (up to the MAWP of the boiler) may be used as long as the relieving capacity is in excess of the maximum input capacity of the boiler, see boiler rating plate.

The pressure relief valve must be installed at the boiler outlet and in the vertical position, as shown in Figures 8-1(a) through (d), with the drain pipe outlet exiting the side of the pressure relief valve horizontally and elbowing down. If using a higher pressure relief valve, ensure the pressure gauge is sized to display the higher pressure valve.

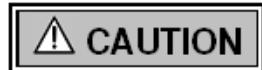

If installed with the incorrect orientation (horizontally with drain pipe out the bottom) the relief valve may not function properly resulting in property damage or personal injury.



Ensure the discharge of the pressure relief is piped to a location where the steam or water will not cause property damage or serious injury.

**Pressure Gauge** – All models come with a factory supplied 30PSI Pressure Gauge. The pressure gauge must be installed at the appliance's outlet prior to any circulators and in the vicinity of the pressure relief valve. See Figures 8-1(a) through (d).

**Figure 8-1(a) Ti200 and Ti100-150 US**

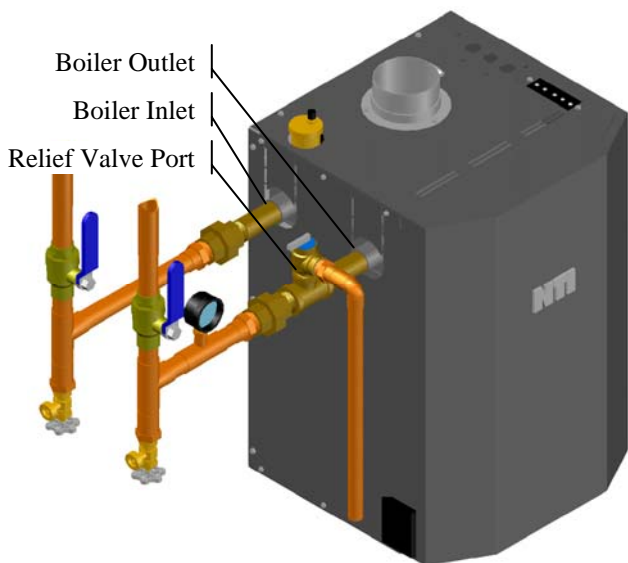

**Figure 8-1(b) Ti100-150 Canada**

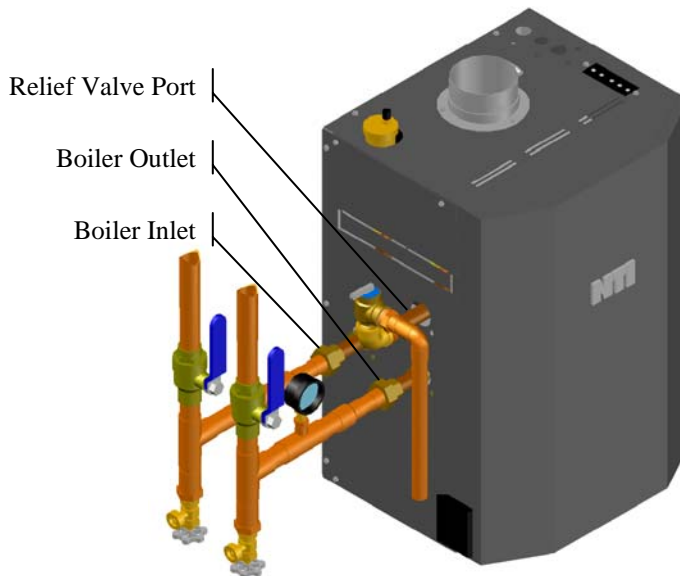

**Figure 8-1(c) Ti200 Combi and Ti150 Combi US**

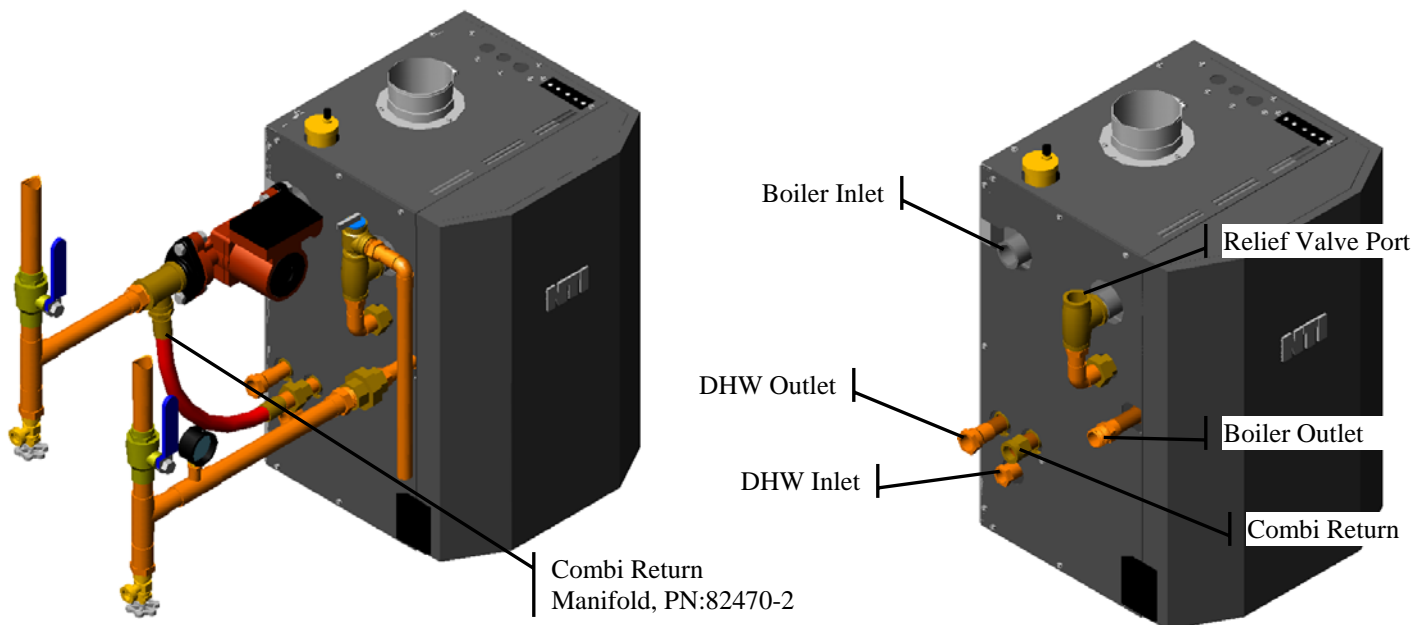

**Figure 8-1(d) Ti150 Combi Canada**

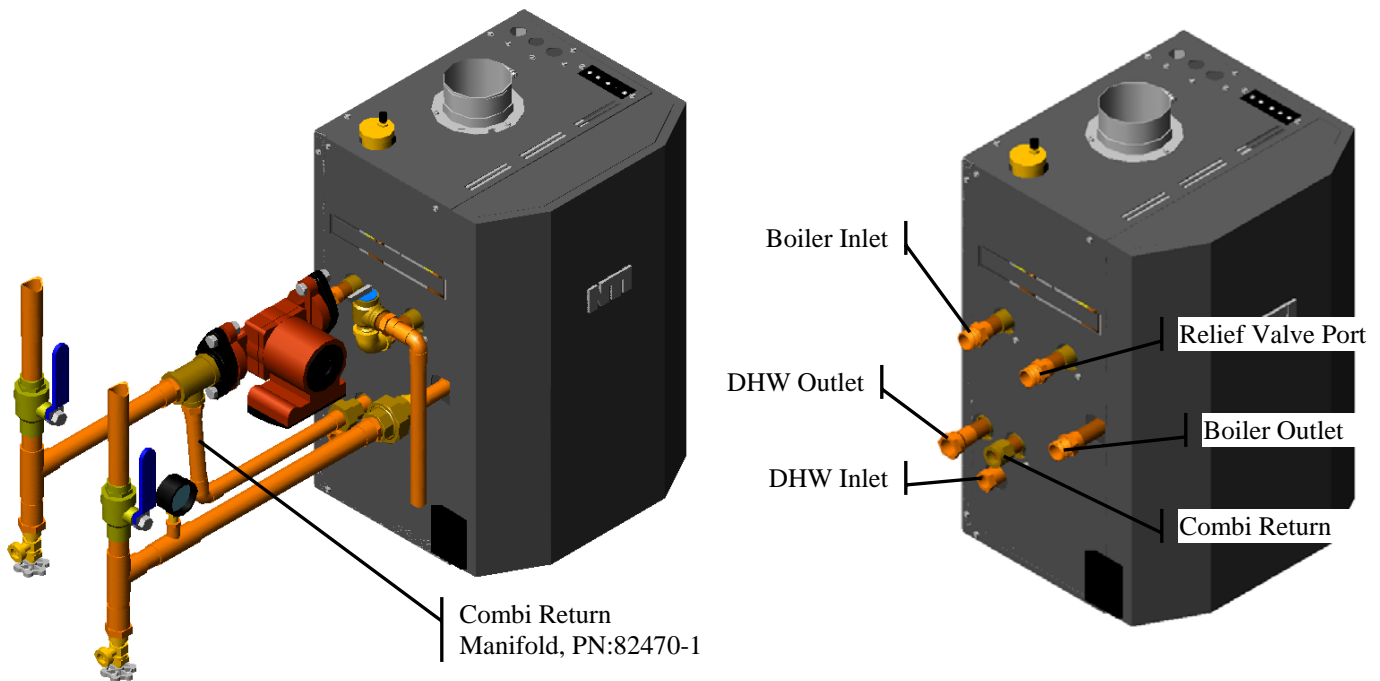

**Boiler System Plumbing**

The Trinity Ti boiler uses a low mass heat exchanger that requires a minimum rate of forced water circulation any time the burner is operating (See Table 8-3 for minimum flow rates). To ensure the minimum flow rate is attained, the boiler shall be installed in a “Primary/Secondary” plumbing configuration utilizing “Closely Spaced Tees” to de-couple the Boiler-Primary loop from the System-Secondary loop(s). See the example of Primary/Secondary Loop configuration in Figure 8-2.

**System Components** – As well as a Primary/Secondary Loop Configuration utilizing closely spaced tees a properly installed system will include the following major components identified in Table 8-2 as a minimum.

**Table 8-2 System Major Component Checklist**

Factory Supplied Components	Field Supplied Components
<input type="checkbox"/> Pressure Relief Valve (30PSI)	<input type="checkbox"/> Boiler Loop Circulator (Pump C1 in Figure 8-2)
<input type="checkbox"/> Pressure Gauge (30PSI)	<input type="checkbox"/> DHW Loop Circulator (Pump Ap in Figure 8-2, for applications utilizing Indirect Fired Water Heater only)
<input type="checkbox"/> DHW Flow Switch (Combi Only)	<input type="checkbox"/> Central Heat (CH) Loop Circulator(s) (e.g. Zone Circulators in Figure 8-2)
<input type="checkbox"/> Combi Return Manifold, PN:82470-1 (or -2) see Figures 8-1(c) and (d) (Combi Only)	<input type="checkbox"/> Central Air Removal Devices (i.e. Micro Bubbler or Air-Scoop)
	<input type="checkbox"/> Pressure Regulating “Fill Valve”
	<input type="checkbox"/> Backflow Preventor
	<input type="checkbox"/> Expansion Tank

**Circulating Pumps** – The Trinity Ti boiler is equipped with two 120VAC pump outputs:

1. **PUMP Ap (“Aux. Circ.”)** – Operates during a Domestic Hot Water demand (A-C contact closure).
2. **PUMP C1 (“Circ.”)** – Operates during a Space Heat demand (T-C contact closure). Also operates during a DHW demand on Combi boilers only.

Ensure pumps are oriented as per the manufacturers’ instructions. Wiring of these circulators will depend on the boiler configuration chosen, i.e. Combi or non-Combi boiler, see Section 10.0 for further wiring details.

**NOTICE**

Circulators responsible for forcing the water flow rate through the boiler must be sized according to Table 8-3, see Figure 8-2 for details.

**WARNING**

Failure to ensure the minimum water flow rate through the boiler when the burner is on will not only reduce the operating efficiency of the boiler, but may also cause premature failure, overheating and void the warranty. Failure to follow instructions may result in fire, property damage, serious injury or death.

**Table 8-3 Minimum Circulator and Pipe Sizes**

Model	Restriction Head Loss	Minimum Pipe Size	Min. Flow (GPM)	Max. Temp. Rise	Minimum Primary Loop Pump Size		
					B&G	Grundfos	Taco
100 <sup>1</sup>	7' at 6 GPM	1"	4.5	45°F	NRF-22	UP 15-58	008
150	8' at 7 GPM	1"	6	45°F	PL-30	UP 26-99	0011
200	7' at 10 GPM	1-1/4"	8	45°F	PL-36	UP 26-99	0011

**Notes:**

1 – Must use pump model specified for Ti150 when using a safety flow switch.

**Air Removal** – The boiler and system plumbing layout must be configured to promote the removal of air from the water. Air vents and bleeders must be strategically placed throughout the system to aid in purging the air from the system during commissioning of the boiler. The system must also employ the use of a strategically located air removal device, such as an air scoop or micro-bubbler, designed to remove the air from the water as it flows through the system.

**NOTICE**

Follow the installation instructions included with the air removal device when placing it in the system; air removal devices generally work better when placed higher in the system. Always locate air removal devices in areas of the system that have a guaranteed positive pressure, e.g., in close proximity to the water fill and expansion tank.

**NOTICE**

Trinity boilers are equipped with an automatic air removal device to aid in the purging of air from the boiler during the initial fill. This device is **NOT** intended, nor is it sufficient to remove the air from the system plumbing, even if the air makes it back to the boiler. A strategically located air removal device must be installed in the system.

**Low Water Cutoff / Flow Switch** – The Trinity Ti boiler is not provided with a LWCO or Flow Switch, however one is to be field installed in any application where the boiler is located above the radiation or where local authorities require it. NTI recommends installing a LWCO or flow switch to prevent the boiler from firing without water in the heat exchanger. When used, Low Water Cut Off and Flow Switch devices must be installed in accordance with the manufacturer’s instructions and the following:

- LWCO must be at least 6” above the top of the boiler.
- Flow Switch must be installed in a 1” diameter line directly in series with the boiler at all times. NTI recommends a “McDonnell & Miller” model number “FS8-W”.
- The normally open contacts of either a LWCO or Flow Switch must be wired in series with the boiler’s 24V limit circuit, see wiring schematic for more details.

**⚠ DANGER**

Operating the boiler without sufficient water level will result in overheating and may result in property damage, fire, personal injury or loss of life.

**Expansion Tank** – The expansion tank must be sized in accordance with the water volume of the system as well as the firing rate of the appliance. It is important to locate the expansion tank, and make-up water fill, on the inlet side of any circulator in the system, as doing so will guarantee the lowest pressure in the system will be at least equal to the tank and make-up water pressure. See examples in Figures 8-2 and 8-3.

**⚠ CAUTION**

Ensure the expansion tank cannot become isolated from the boiler anytime the system is operating. Failure to follow these instructions may result in discharge of the Pressure Relief Valve may result in property damage or personal injury.

**NOTICE**

The installation of flow checks, motorized valves or other shutoff devices (other than for the purpose of servicing) are not permitted between the location of the “Closely Spaced Tees” and the expansion tank; see Figures 8-2 and 8-3.

**Indirect Fired Water Heater** – The indirect fired water heater is in series with the boiler during a demand for DHW. Therefore it is important to use an Indirect Fired Water Heater that has minimal head loss. Indirect fired water heater head loss must not exceed those specified in Table 8-4. See Table 8-3 for minimum circulator specifications.

**Table 8-4 Maximum Indirect Fired Water Heater Head Loss (Boiler Side) at Minimum Flow**

Ti100	Ti150	Ti200
6' at 5 GPM	10' at 6 GPM	14' at 8 GPM

**Figure 8-2 Boiler System Plumbing (non-Combi)**

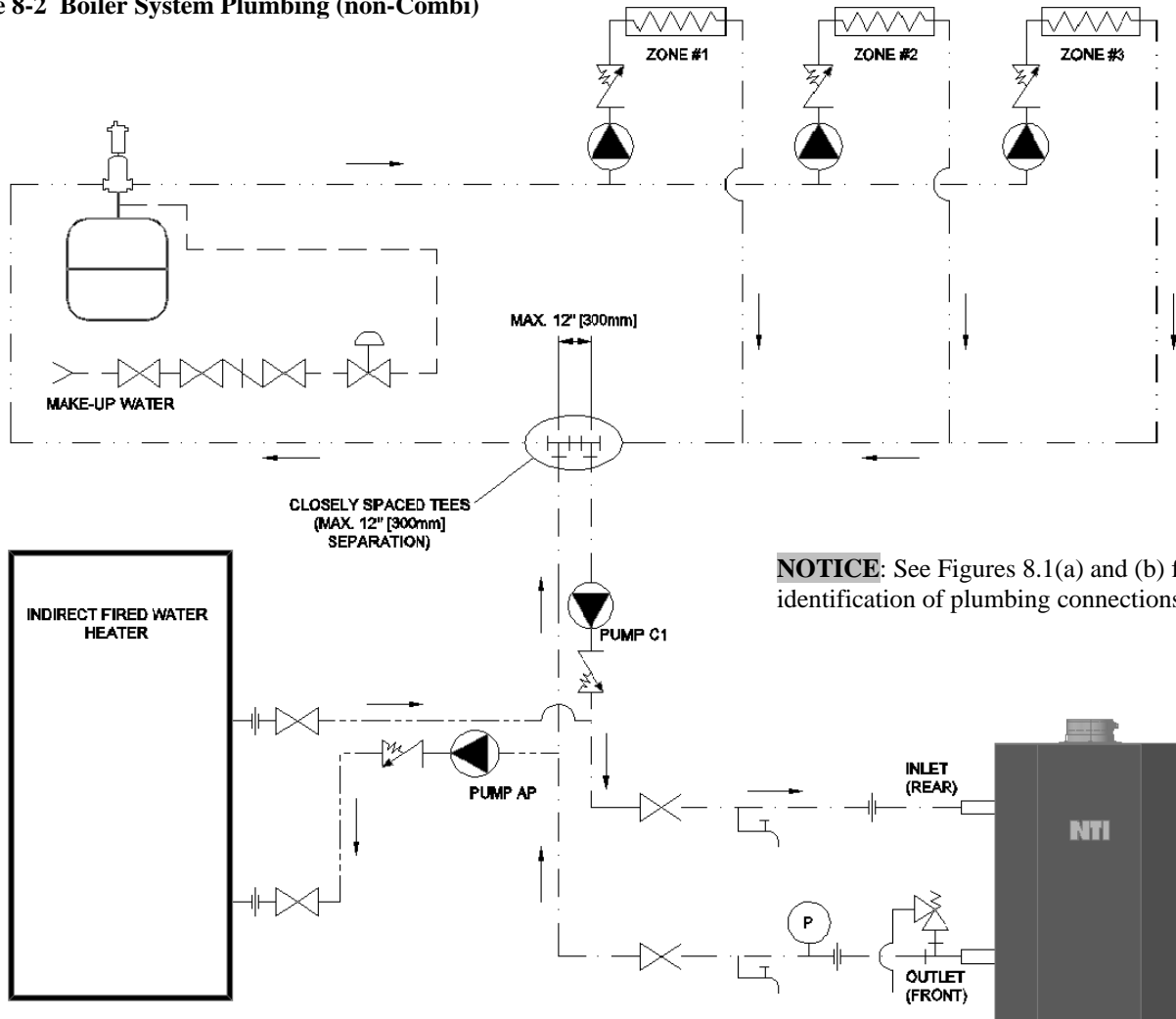

**NOTICE:** See Figures 8.1(a) and (b) for identification of plumbing connections.

LEGEND					
SYMBOL	DESCRIPTION	SYMBOL	DESCRIPTION	SYMBOL	DESCRIPTION
	MAKE-UP WATER		BACKFLOW PREVENTOR		AIR SEPARATOR
	PRIMARY LOOP		PRESSURE RELIEF VALVE		PUMP
	CENTRAL HEATING SECONDARY LOOP		PRESSURE REGULATING VALVE		UNION
	DHW SECONDARY LOOP		DRAIN VALVE		TEE
	ISOLATION VALVE		AIR VENT		PRESSURE GAUGE
	SPRING CHECK VALVE		EXPANSION TANK		FLOW DIRECTION
	ZONE LOAD				

**Figure 8-3 Boiler System Plumbing (Combi)**

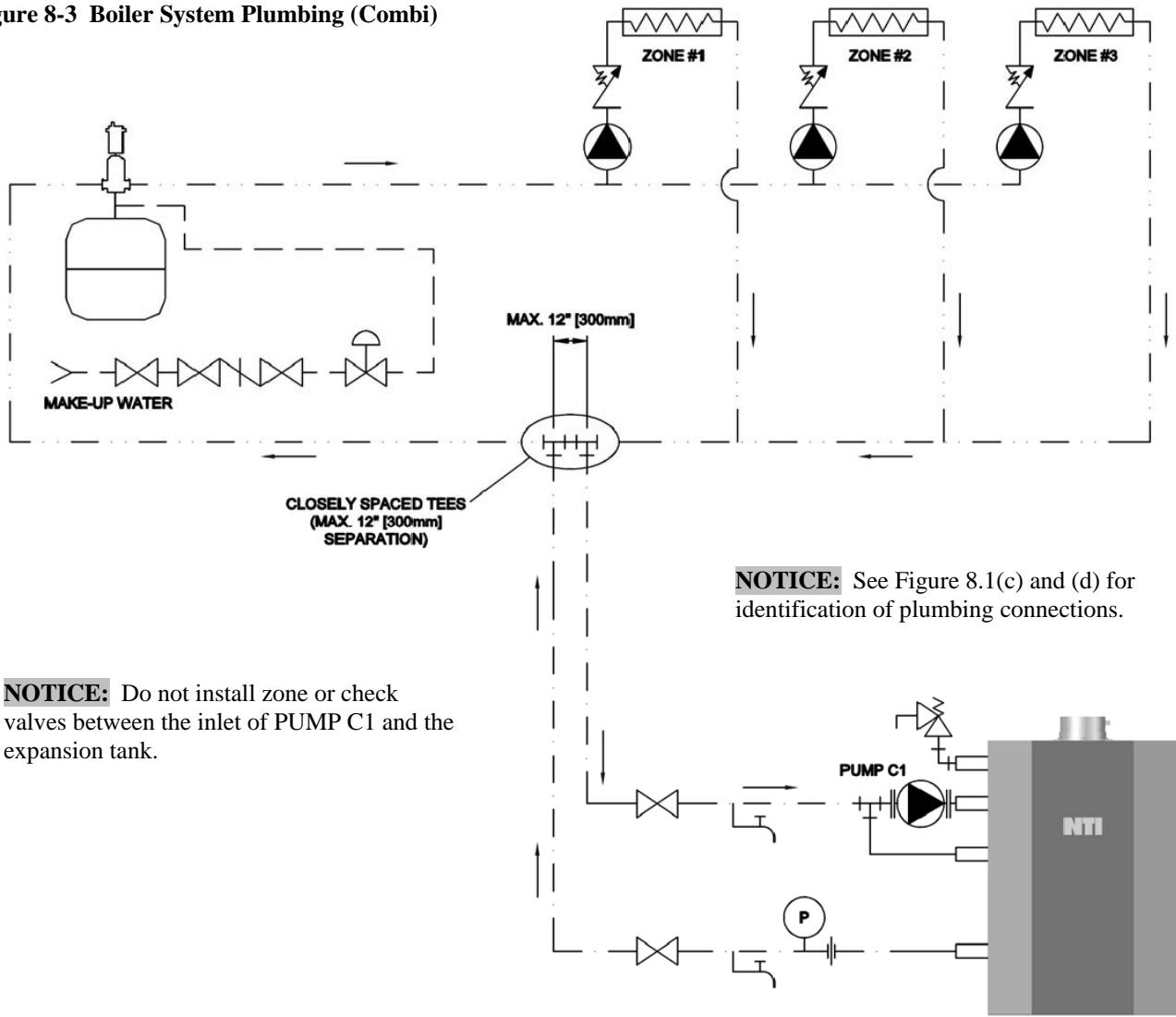

**NOTICE:** Do not install zone or check valves between the inlet of PUMP C1 and the expansion tank.

**NOTICE:** See Figure 8.1(c) and (d) for identification of plumbing connections.

LEGEND					
SYMBOL	DESCRIPTION	SYMBOL	DESCRIPTION	SYMBOL	DESCRIPTION
---	MAKE-UP WATER		BACKFLOW PREVENTOR		AIR SEPARATOR
---	PRIMARY LOOP		PRESSURE RELIEF VALVE		PUMP
---	CENTRAL HEATING SECONDARY LOOP		PRESSURE REGULATING VALVE		UNION
---	DHW SECONDARY LOOP		DRAIN VALVE		TEE
	ISOLATION VALVE		AIR VENT		PRESSURE GAUGE
	SPRING CHECK VALVE		EXPANSION TANK		FLOW DIRECTION
	ZONE LOAD		PUMP FLANGE		ELBOW

## 9.0 COMBI BOILER DHW PLUMBING AND OPERATION

The Trinity Ti boiler comes in two versions; Standard (non-Combi) and Combi. Both versions are designed to provide Space and Domestic Hot Water (DHW) heating. To provide DHW heating, the Standard version must be installed in combination with an Indirect Fired Hot Water Heater, see Figure 8-2 for installation details. The Combi version of the Trinity incorporates an indirect fired DHW heat exchanger (Braze Plate) and the controls necessary to heat DHW without requiring the addition of an Indirect Fired Hot Water Heater. The Combi option is only available on models Ti150 and Ti200, as smaller units would not produce adequate DHW.

The Trinity Combi is designed for installations where there is a limited DHW demand, such as smaller apartments and condos. In applications where there is a greater DHW demand NTI recommends the Combi in conjunction with a DHW storage tank (Figure 9-2), or a Standard Trinity in conjunction with an Indirect Fired Hot Water Heater (Figure 8-2).

### DHW Description of Operation

The Trinity Combi heats domestic hot water on demand, indirectly, using a braze plate heat exchanger. Using the factory supplied and field installed flow switch, the Trinity Combi recognizes a DHW demand when the flow switch provides a contact closure to terminals A-C on the top of the boiler; the contacts of the flow switch close at a DHW flow rate of approximately 0.5 gpm or greater. Once the flow switch contact is made, the Combi immediately goes into DHW mode regardless of the status of the Central Heating system (with the exception of an Er5 DHW lockout, see troubleshooting section). The burner fires and the Combi attempts to achieve a boiler temperature equal to the programmed “LO” setting (See Section 11.0). The LO setting is accessed via the menu in the Sentry 2100 controller, and should be set at a value sufficient to heat the potable water, i.e. 150-165°F. NTI provides a Thermostatic Mixing Valve adjustable from 100 to 145°F; the mixing valve shall be installed between the Combi DHW outlet fitting and the hot water supply pipe to the fixtures (See Figures 9-1 and 9-2), thus providing user protection from scalding hot water.

#### NOTICE

Code requirements may require the maximum setting of the Thermostatic Mixing Valve to be fixed at 120°F or lower, see “Thermostatic Mixing Valve” below and the instructions included with the valve.

### Combi DHW Plumbing & Set-up

**DHW Inlet & Outlet Connections** – The Trinity Ti Combi has two potable water connections, Inlet & Outlet, which exit the left side of the Trinity Cabinet; on the inside of the cabinet the two lines are connected to the Braze Plate Heat Exchanger; see Figures 8-1(c) and (d) for identification of the DHW Inlet and Outlet fittings. See Figures 9-1 and 9-2 for installation details.

**Thermostatic Mixing Valve** – A Sparcomix AM101-US-1 is provided with your package. This valve regulates the water temperature leaving the plate heat exchanger, and must be used in every instance. The dial can be set to the desired temperature required. Consult the Honeywell manual SD/IS150 for detailed instructions and settings. (Note: the valve must be set to a supply temperature of not more than 120°F. It is the responsibility of the installer to set the valve and remove the dial.)

#### WARNING

**Scald Hazard** - Hotter water increases the risk of scald injury. There is a hot water scald potential if the thermostatic mixing valve is set too high. Be sure to follow the adjustment instructions provided with the thermostatic mixing valve. Failure to follow these instructions may result in serious injury or death.

**DHW Filter** – Install a 100 micron or lower filter prior to the entrance of the DHW flow switch. Failure to protect the flow switch from dirt and debris will cause it to malfunction.

**Check Valve** – A check valve must be field provided and installed on the outlet of the mixing valve to prevent expansion devices downstream from back flowing when the water pressure drops during cold water draws. Failure to prevent the backflow will cause water to flow forward through the flow switch, activating it, when the cold-water draw has ended and the water pressure increases.

**Throttling Valve** – Install a throttling valve, after the mixing valve, to regulate the maximum hot water flow rate. The Combi is limited to a firing rate of 150MBH (200MBH for Ti200C); therefore excessive flow rates will result in cooler hot water temperatures.

**Drain and Isolation Valves** – Install drain and isolation valves on the inlet and outlet of the braze plate heat exchanger, as shown in Figures 9-1 and 9-2 so it can be flushed free of possible build-up caused by dirt or hard water.

**Hard Water** – To prevent the formation of scale on the inside of the braze plate heat exchanger and other components in the domestic hot water system, water with hardness higher than 50 ppm Calcium Carbonate must be treated with a “Water Softener” prior to entering the appliance. Plugging of the domestic system by scaling or accumulation of dirt is not the responsibility of NY Thermal Inc., and suitable steps shall be taken to avoid it.

**Cleaning** – Brazed plate heat exchangers operate with high turbulence flow, even at low flow rates. This high turbulence keeps small particles in suspension minimizing fouling and scaling. However, in some applications the fouling tendency can be very high, e.g. when using extremely hard water at high temperatures. In such cases it is always possible to clean the exchanger by circulating a cleaning liquid. Use a tank with weak acid, 5% phosphoric acid or, if the exchanger is frequently cleaned, 5% oxalic acid. Pump the cleaning liquid through the exchanger. For optimum cleaning, the cleaning solution flow rate should be a minimum of 1.5 times the normal flow rate, preferably in a back-flush mode. After use, do not forget to rinse the heat exchanger carefully with clean water. A solution of 1-2% sodium hydroxide (NaOH) or sodium bicarbonate (NaHCO<sub>3</sub>) before the last rinse ensures that all acid is neutralized. Clean at regular intervals.

### **Instantaneous DHW (w/o Storage Tank)**

The Combi will provide domestic hot water continuously when flow is sensed by the flow switch. This method is the most efficient means of heating water by allowing the boiler to operate at a lower return water temperature, thus increasing combustion efficiency, and by minimizing standby losses. See Figure 9-1 for installation details.

**DHW Limitations** – As the Combi produces domestic hot water instantaneously; there are inherent limitations of the system:

- **NO STORAGE** - As there is no water storage, the boiler can only provide water at the temperature specified at the corresponding flow rates. Flow through the fixtures must be regulated so not to exceed the ability of the boiler to heat the water. **MORE FLOW = LESS TEMPERATURE.** See “Procedure for Setting up Domestic Hot Water” and Tables 9-1 and 9-2.
- **DOESN'T MAINTAIN TEMPERATURE** – When there is no call for domestic the unit is off. From a dead stop the unit will detect flow and start providing heat in 15 seconds, and be up to capacity by 25 seconds. Once running, the unit can provide an endless amount of hot water. If the flow is momentarily turned off for whatever reason, the unit will turn off. Once off, the unit must relight, and not provide heat for 45-75 seconds. This will cause cold unheated water to pass through the unit, and advance through the domestic plumbing between the previously heated (hot) water, and the new (hot) water. This can be mistaken for an inability to adequately heat the water.

**“Storage”Feature (St0)** – For improved domestic hot water comfort, the Combi incorporates a “Storage” feature. This storage feature, when enabled, will keep the boiler water hot for a period of 1 to 24 hours following a call for domestic hot water (See Section 11.0 for further information of setting control). When the boiler water drops below 140°F the boiler will fire and bring the boiler to 180°F before shutting off. This “Storage” feature helps in reducing the wait time associated with a tankless hot water system. In systems where a storage tank is used (See Figure 9-2), this feature should be disabled, e.g. set to OFF.

**Procedure for Setting up Domestic Hot Water** – If the Combi is being installed in an application that uses municipal water, often the pressure is high enough to generate flow rates at the faucets that will exceed the appliances capacity to heat it. See the following tables to determine what flow can be expected at various inlet and outlet water temperatures.

**Table 9.1 Ti150 Combi DHW Flow Rates (USgpm)**

		Inlet Water Temperature (deg. F)						
		40	45	50	55	60	65	70
Outlet Water (F)	110	3.9	4.2	4.5	4.9	5.4	6.0	6.7
	115	3.6	3.9	4.2	4.5	4.9	5.4	6.0
	120	3.4	3.6	3.9	4.2	4.5	4.9	5.4
	125	3.2	3.4	3.6	3.9	4.2	4.5	4.9
	130	3.0	3.2	3.4	3.6	3.9	4.2	4.5
	135	2.8	3.0	3.2	3.4	3.6	3.9	4.2
	140	2.7	2.8	3.0	3.2	3.4	3.6	3.9

**Table 9.2 Ti200 Combi DHW Flow Rates (USgpm)**

		Inlet Water Temperature (deg. F)						
		40	45	50	55	60	65	70
Outlet Water (F)	110	5.1	5.5	6.0	6.5	7.2	8.0	9.0
	115	4.8	5.1	5.5	6.0	6.5	7.2	8.0
	120	4.5	4.8	5.1	5.5	6.0	6.5	7.2
	125	4.2	4.5	4.8	5.1	5.5	6.0	6.5
	130	4.0	4.2	4.5	4.8	5.1	5.5	6.0
	135	3.8	4.0	4.2	4.5	4.8	5.1	5.5
	140	3.6	3.8	4.0	4.2	4.5	4.8	5.1

To avoid having too much flow at the faucets use the throttling valve located at the “Cold Supply” in Figure 9-1 to limit the overall flow of domestic hot water. Follow these instructions to achieve the best delivery of DHW:

- Open throttle valve fully.
- Turn the dial on the mixing valve to the desired setting (do not exceed 120°F).
- Create the maximum amount of DHW flow that is likely to occur on a regular basis. (Usually tub faucet, or choose two other faucets)
- Allow the boiler to reach steady state, and then throttle the shut-off valve until the hot water exiting the plate heat exchanger is slightly warmer than the mixed water exiting the mixing valve. Ensure the boiler is firing at the maximum rate, if not increase the Sentry “LO” setting and repeat this step. (It is beneficial to keep the “LO” setting as low as possible to limit short cycling and maintain efficiency)

**NOTICE**

If the flow rates listed in Tables 9-1 and 9-2 are not high enough for the application, install a storage tank with re-circulating loop as per below and Figure 9-2.

**Trinity Combi w/DHW Storage Tank**

To completely avoid the DHW limitations inherent with on demand hot water heating, install a DHW storage tank as per the DHW plumbing schematic shown in Figure 9-2. When the tank temperature is insufficient, an Aqua-stat (T-stat) located within the storage tank completes a 120VAC circuit to a potable (bronze or Stainless Steel) circulating pump. The pump circulates water from the bottom of the storage tank (typical location of a drain fitting) to the DHW inlet fitting of the Trinity Combi (see Figures 8-1(c) and (d) for identification of plumbing fittings). The DHW flow switch senses the water flow and triggers a DHW demand; heated water flows from the Combi and enters the inlet fitting of the storage tank.

**NOTICE**

In lieu of the DHW flow switch, NTI recommends using an isolation relay activated with the potable re-circulating pump. The isolated end-switch of the relay would be wired to the boiler’s A-C terminals in place of the flow switch wires.

**Figure 9-1 Combi DHW Piping (no Storage)**

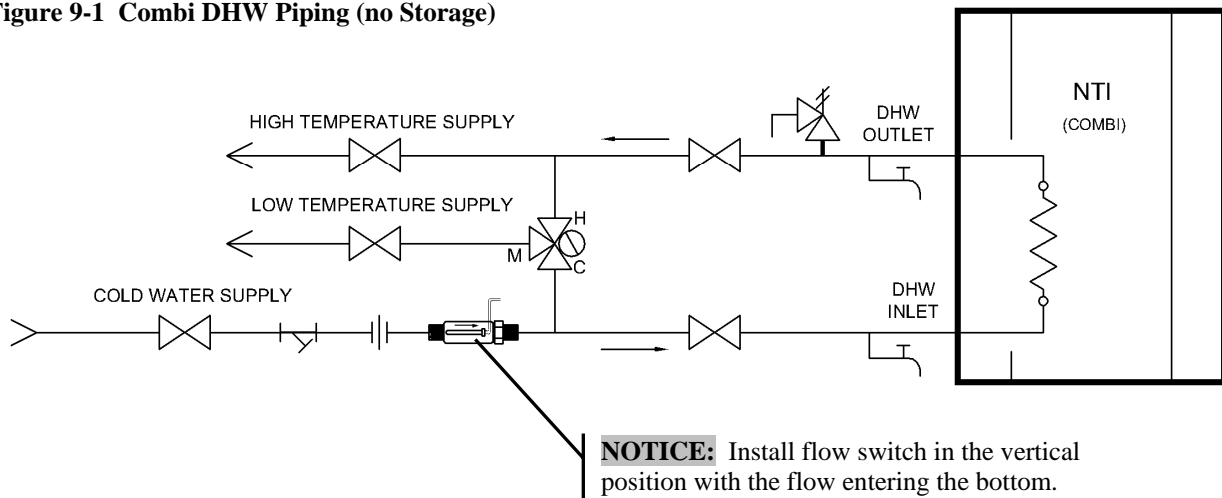

**Figure 9-2 Combi DHW Piping (w/ Storage)**

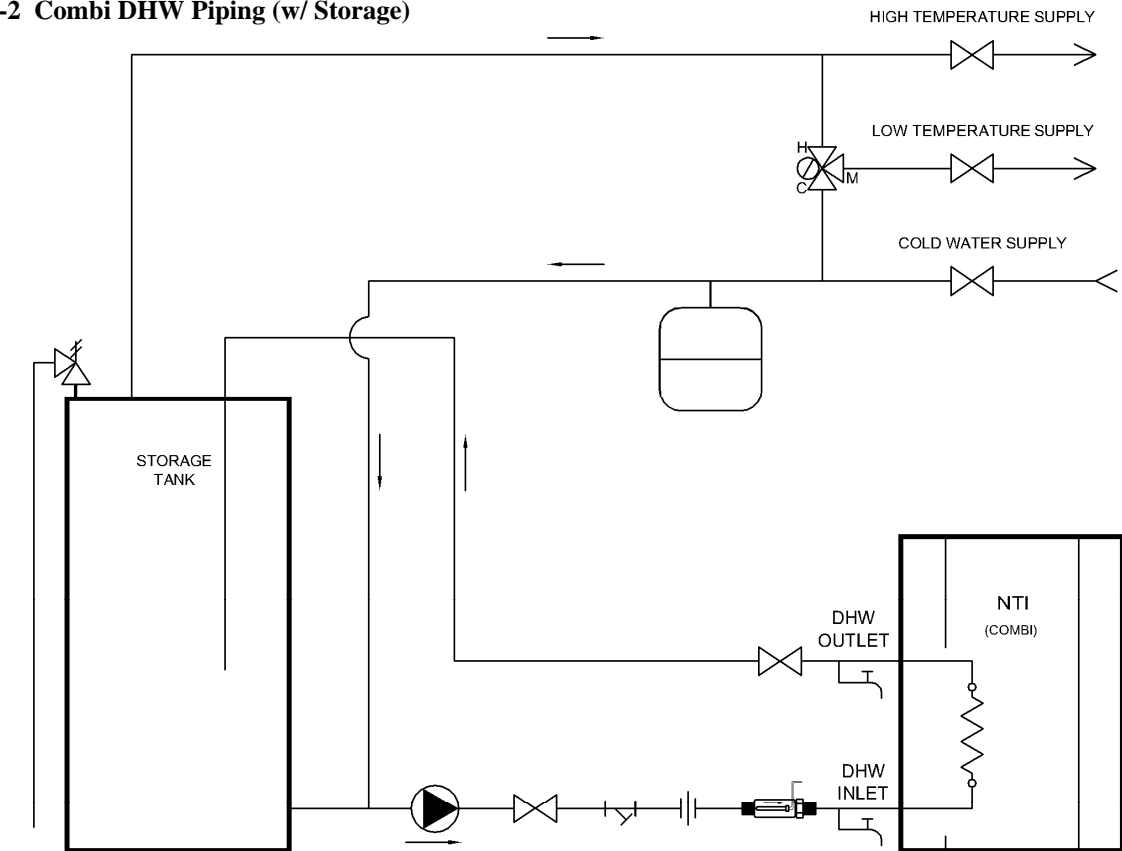

LEGEND					
SYMBOL	DESCRIPTION	SYMBOL	DESCRIPTION	SYMBOL	DESCRIPTION
	ISOLATION / THROTTLE VALVE		BRONZE PUMP		FLOW SWITCH
	DRAIN VALVE		THERMOSTATIC MIXING VALVE		Y STRAINER
	EXPANSION TANK		TEMPERATURE AND PRESSURE RELIEF VALVE		BRAZED PLATE HEAT EXCHANGER

## 10.0 WIRING

All wiring must be in accordance with the Canadian Electrical code, CSA C22.2 and any applicable local codes. Ensure that the wiring complies with this manual. The boiler must be electrically grounded in accordance with the National Electrical Code ANSI/NFPA 70, local codes, and/or the Canadian Electrical Code CSA C22.1.



**Avoid Shocks** - To Avoid Electrical Shock, turn off electrical power to the boiler prior to opening any electrical box within the unit. Ensure the power remains off while any wiring connections are being made. Failure to follow these instructions may result in component failure, serious injury or death.



**Field Wiring** - Wire grommets must be used to secure wiring and prevent chafing when passing wiring through the cabinet wall. Failure to follow instructions may damage unit.

### Line Voltage Connections

The Trinity Ti line voltage junction box is located in the upper right corner of the boiler cabinet near the wall; the junction box is accessed by removing the front door of the boiler, followed by the removal of the line voltage junction box cover. Each boiler is provided with one hole and two knockouts for routing field wiring into the line voltage junction box. Line voltage field connections are to be installed in accordance with Figures 10-1 and 10-2 for non-Combi and Combi Trinity boilers respectively and Table 10-1.

**Fuse (120VAC)** – The Trinity Ti Sentry controller is equipped with one 15 Amp fuse to protect the 120VAC pump outputs. The fuse is located under the cover of the Sentry 2100 control.



**Wire Protection** - When passing any wiring through the cabinet of the boiler, the installer must use wire grommets suitable for securing the wiring and preventing chafing. Failure to follow instructions may result in component failure, serious injury or death.



**Power Supply** - The Trinity Ti is designed to be powered using a single phase 120VAC power supply that is fused (or protected via a circuit breaker) to allow a maximum of 15 Amps. Failure to follow instructions may result in component failure, serious injury or death.



**Labeling** - Label all wires prior to disconnecting them when servicing controls. Wiring errors can cause improper and dangerous operation. Failure to follow instructions may result in property damage or personal injury.



**Continuity** - Before connecting the line voltage wiring, perform a continuity check between all wires and ground to make sure that there are no electrical leaks that could blow a fuse or damage electrical components. Also check the polarity of the line and neutral wires. Line must measure 120VAC to ground; neutral must measure zero. Failure to follow instructions may damage the unit.

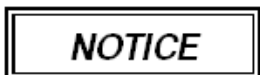

**Max Load** - Circulator outputs Ap (Purple) and C1 (Blue) are each limited to operating a circulator with a maximum current load of 3 Amps or a maximum 1/6 hp motor.

### Low Voltage Connections

The Trinity Ti low voltage (thermostat) connections are located on the top-right on the outside of the boiler cabinet. Low voltage field connections are to be installed in accordance with Figures 10-1 and 10-2 for non-Combi and Combi models respectfully, and Table 10-2.

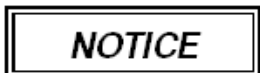

The Trinity Ti Low Voltage connections use a low voltage DC signal for communicating inputs to the Sentry controller. Power cannot be applied to these terminals, nor can the low voltage power supply from these terminals be used to power anything, i.e. **DIGITAL THERMOSTATS CANNOT** be directly connected to the boiler T-C terminals.

## Simplified Wiring Connections

Figure 10-1 Standard Trinity (non-Combi) Wiring Connections

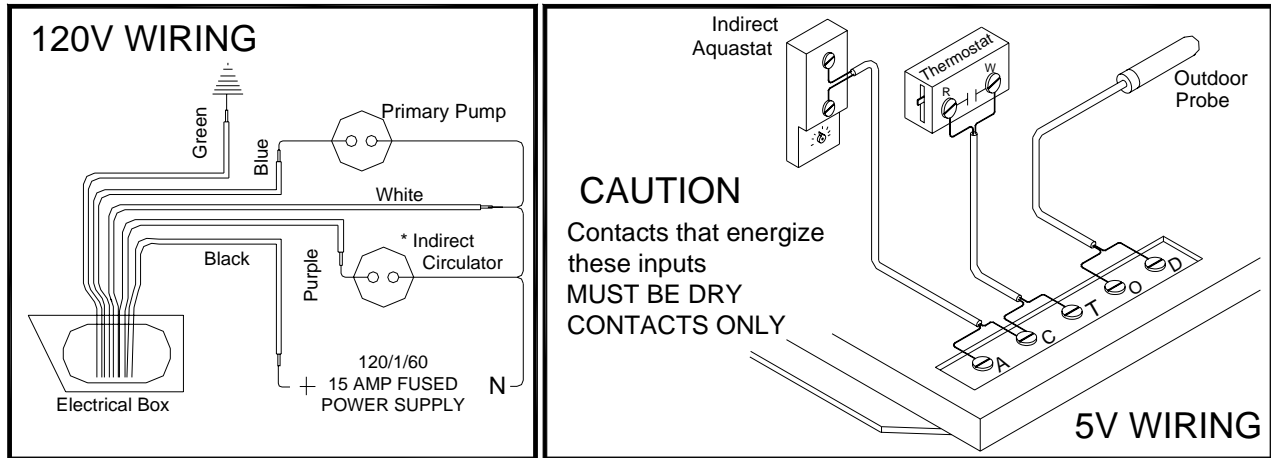

Figure 10-2 Trinity Combi Wiring Connections

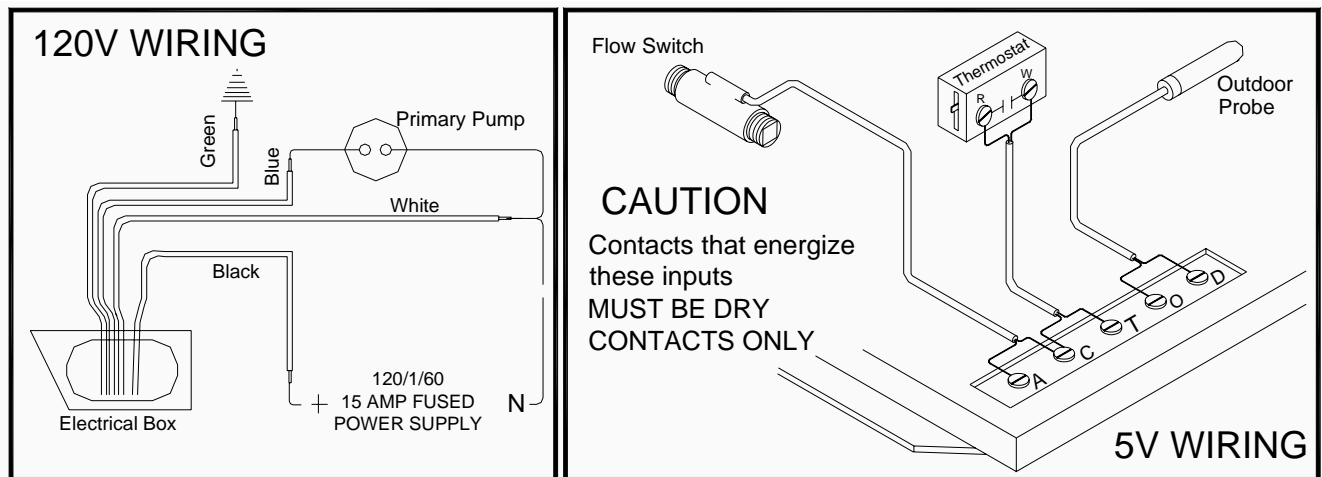

Table 10-1 Line Voltage Field Connections

Connection	Color	Description
L1 (120VAC)	Black	Location for connecting line voltage of the power supply. Note; most installation codes require the installation of a service switch to break line voltage to the appliance.
PUMP Ap	Purple	120VAC output to the DHW circulator; powered during a demand for DHW (A-C contact closure). For Combi boilers the Purple wire is internally routed to the internal DHW diverter valve.
PUMP C1	Blue	120VAC output to the Boiler/Primary Loop circulator; powered during a demand for Space Heat (T-C contact closure) and during a demand for DHW on Combi models only. On non-Combi models the C1 circulator is disengaged during a demand for DHW.
L2 (Neutral)	White	Location for connecting neutral of the power supply and all circulators.
Ground	Green	Location for connecting earth ground and for grounding all of the circulators.

**Table 10-2 Low Voltage Field Connections**

<b>Connection</b>	<b>Description</b>
A	<b>DHW Demand</b> – Input requiring contact with Common terminal “C” to initiate a demand for DHW. Contact made via an isolated end switch (dry contact) from an Aqua-stat located in an Indirect Fired Water Heater for Standard (non-Combi) Trinity boilers. Contact made via the isolated end switch of the factory supplied DHW flow switch for Combi boilers.
C	<b>Input Common</b> – Common contact for inputs “A” and “T”.
T	<b>Space Heat Demand</b> – Input requiring contact with Common terminal “C” to initiate a demand for Space Heating. Contact is made using an isolated end switch (dry contact) via thermostat, zone controller or other device. Note: contact must be an isolated dry contact, i.e. digital thermostats cannot be directly connected to contacts T and C.
O	<b>Outdoor Temperature Sensor</b> – A wall mountable OD Sensor is included with each boiler.
D	When connected to terminals O and D, the control will indicate the outdoor temperature and adjust the boiler temperature set point during a Space Heat demand, see Section 11.0 for details.

## Advanced Wiring Systems

**Figure 10.3 Zone Valve System – No Zone Controller**

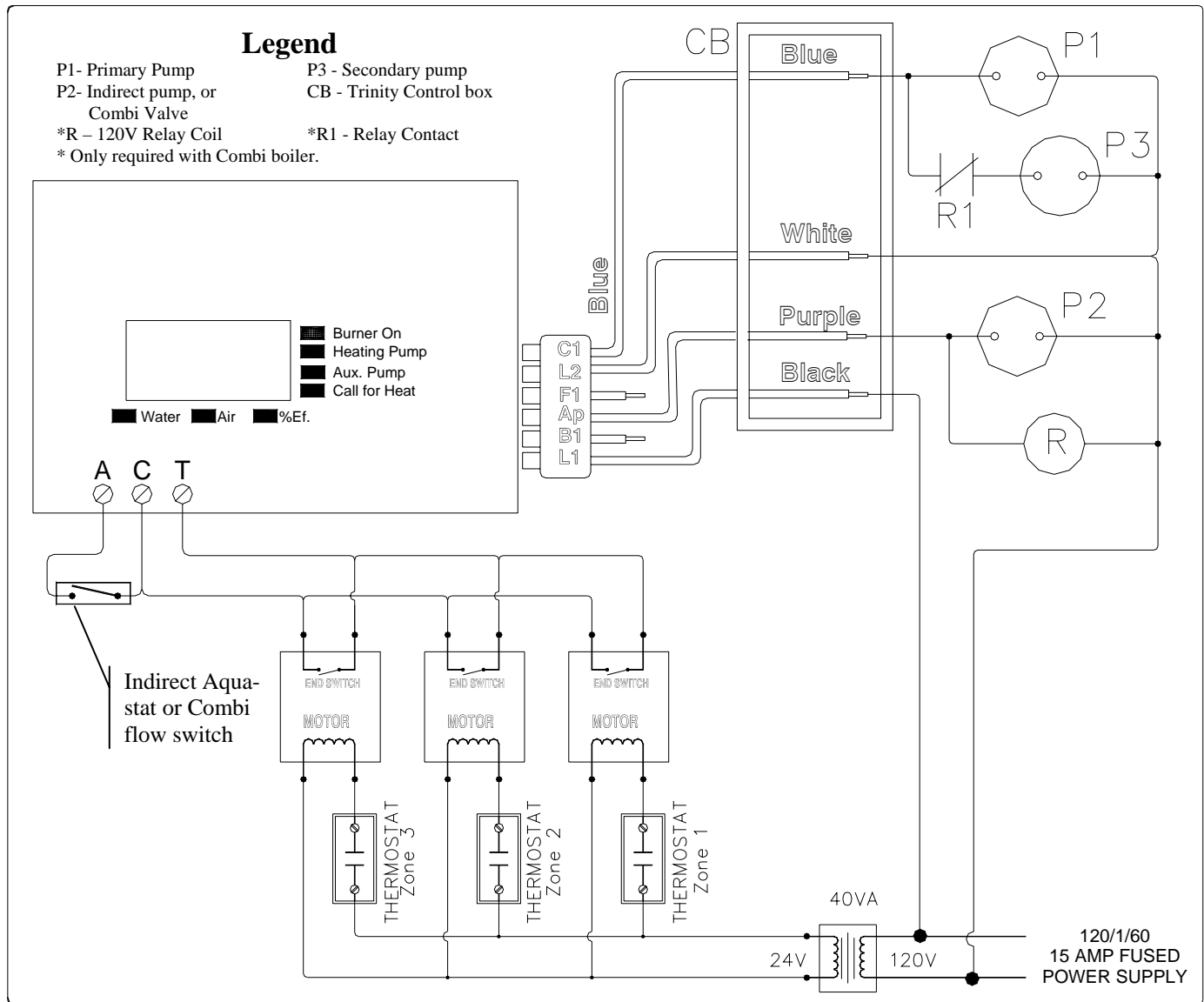

### Zone Valve System – No Zone Controller

Figure 10.3 illustrates a typical wiring configuration required for a heating system using zone valves without a zone valve controller.

**Operation** - Room thermostat closes circuit to zone valve motor, thus opening the valve. When the valve is opened, the end switch closes the circuit between terminals T-C at the Trinity Ti Low Voltage field connection (See Table 10-2 and Figures 10-1 and 10-2). The Sentry 2100 provides power to the primary pump (P1) and secondary pump (P3) via the C1 (blue) pump output, see Table 10-1 and Figures 10-1 and 10-2. The controller then operates the burner to maintain the Space Heat Set-point (HI), see Section 11.0.

**NOTICE**

**Combi Boilers** - The indirect pump is replaced by the internal diverter valve in Combi boilers. Combi boilers using this configuration must utilize a field supplied 120VAC relay (R) with a normally closed contact (R1). The R relay is powered with the internal diverter valve on a demand for DHW; the R1 relay contact opens preventing the Secondary pump (P3) from operating on a demand for DHW.

**Figure 10.4 Zone Valve System – w/Zone Controller**

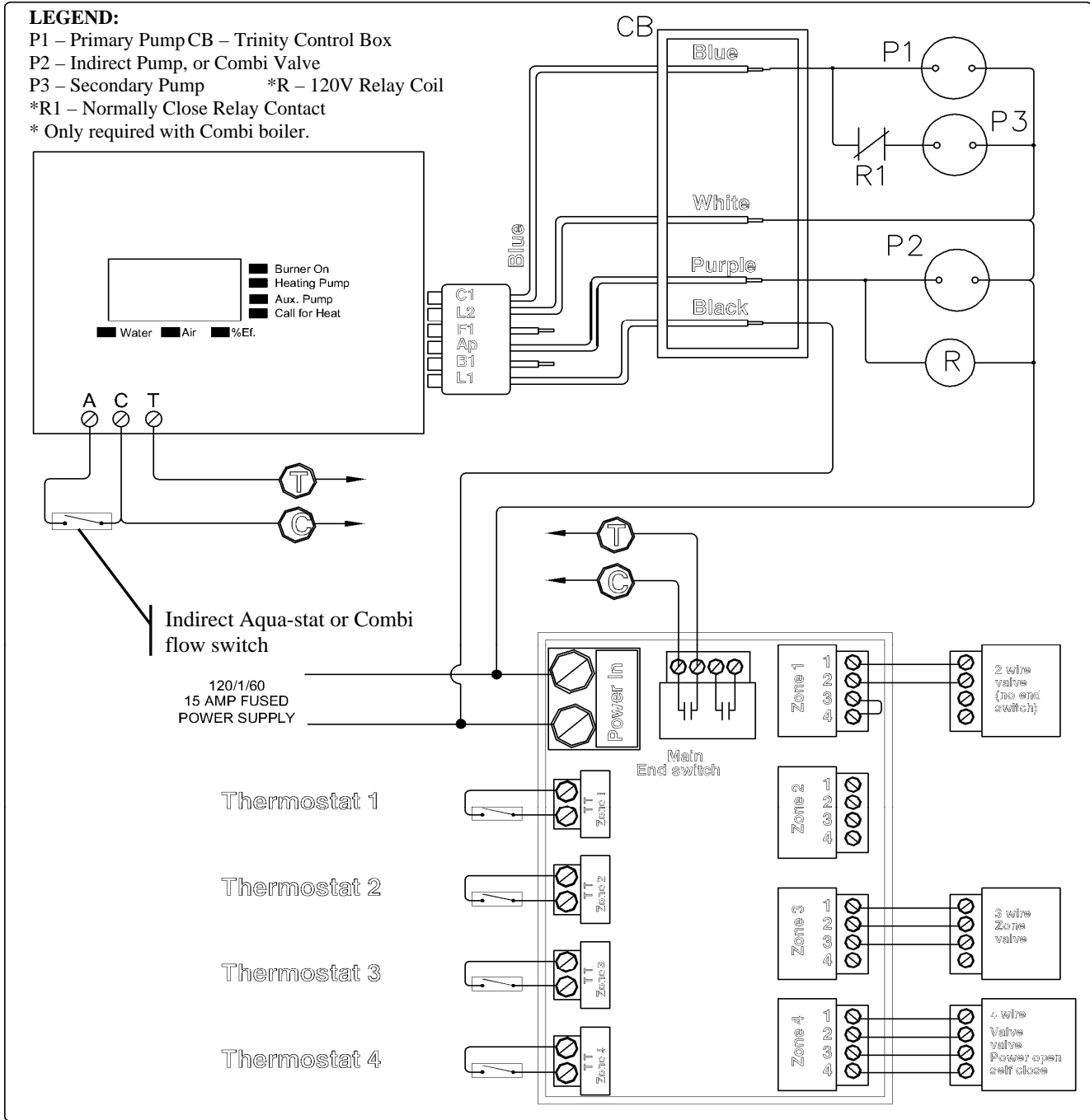

**Zone Valve System – w/Zone Controller**

Figure 10.4 illustrates a typical wiring configuration required for a heating system using zone valves with a zone valve controller (Example shows a Taco model ZVC404).

**Operation** - Room thermostat closes circuit to TT terminals of the zone controller. The controller energizes the appropriate zone valve and closes the circuit between terminals T-C at the Trinity Ti Low Voltage field connection (See Table 10-2 and Figures 10-1 and 10-2). The Sentry 2100 provides power to the primary pump (P1) via the C1 (blue) pump output, see Table 10-1 and Figures 10-1 and 10-2. The controller then operates the burner to maintain the Space Heat set-point (HI), see Section 11.0.

**NOTICE**

**Combi Boilers** - The indirect pump is replaced by the internal diverter valve in Combi boilers. Combi boilers using this configuration must utilize a field supplied 120VAC relay (R) with a normally closed contact (R1). The R relay is powered with the internal diverter valve on a demand for DHW; the R1 relay contact opens preventing the Secondary pump (P3) from operating on a demand for DHW.

**Figure 10.5 Zone Circulator Systems**

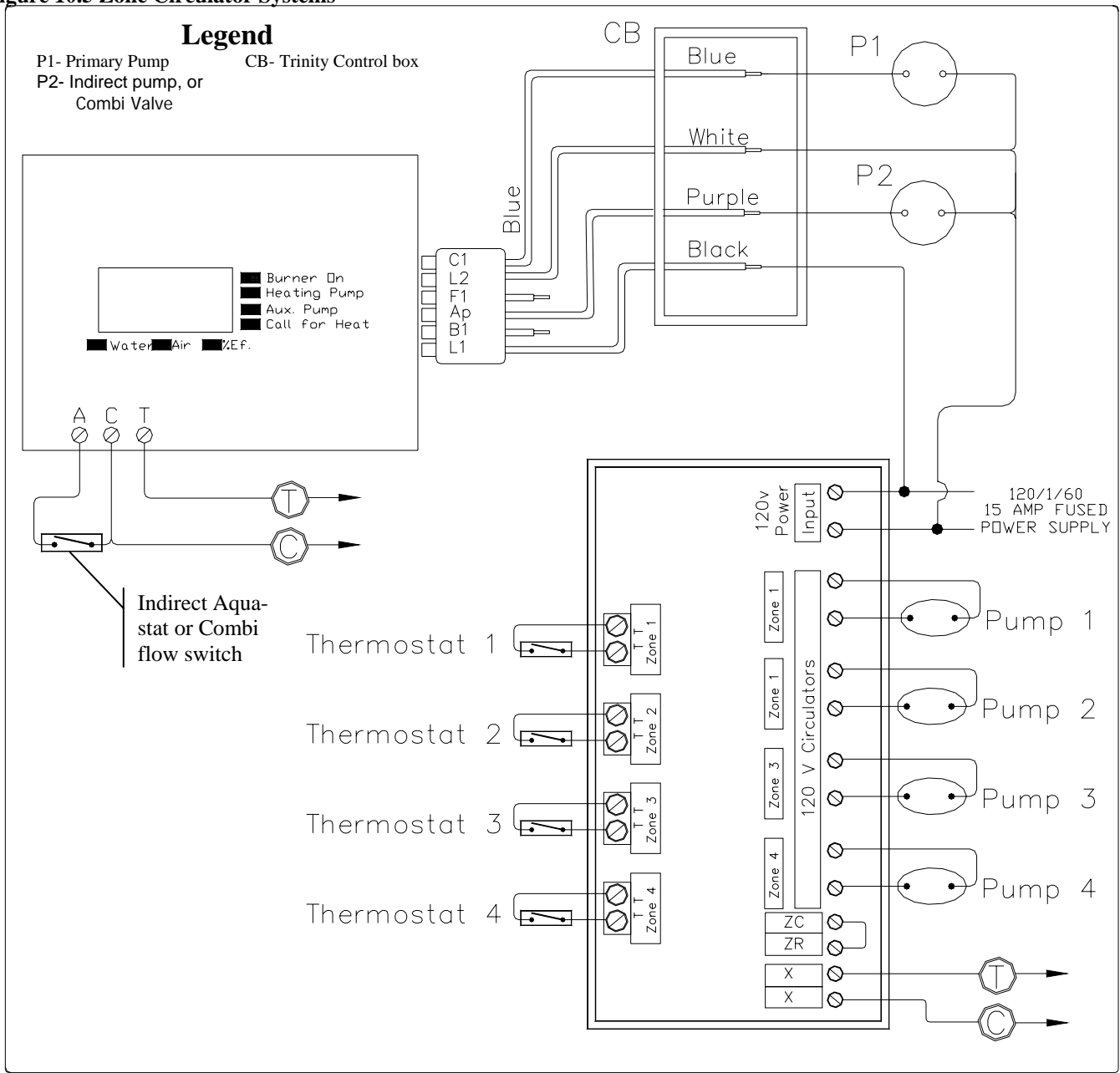

**Zone Circulator System – w/Zone Controller**

Figure 10.5 illustrates a typical wiring configuration required for a heating system using zone circulators with a zone circulator controller (Example shows a Taco model SR504).

**Operation** - Room thermostat closes circuit to TT terminals of the zone controller. The controller energizes the appropriate zone pump and closes the circuit between terminals T-C at the Trinity Ti Low Voltage field connection (See Table 10-2 and Figures 10-1 and 10-2). The Sentry 2100 provides power to the primary pump (P1) via the C1 (blue) pump output, see Table 10-1 and Figures 10-1 and 10-2. The controller then operates the burner to maintain the Space Heat set-point (HI), see Section 11.0.

**Figure 10.6 Zone Circulator System w/Multiple Temperatures**

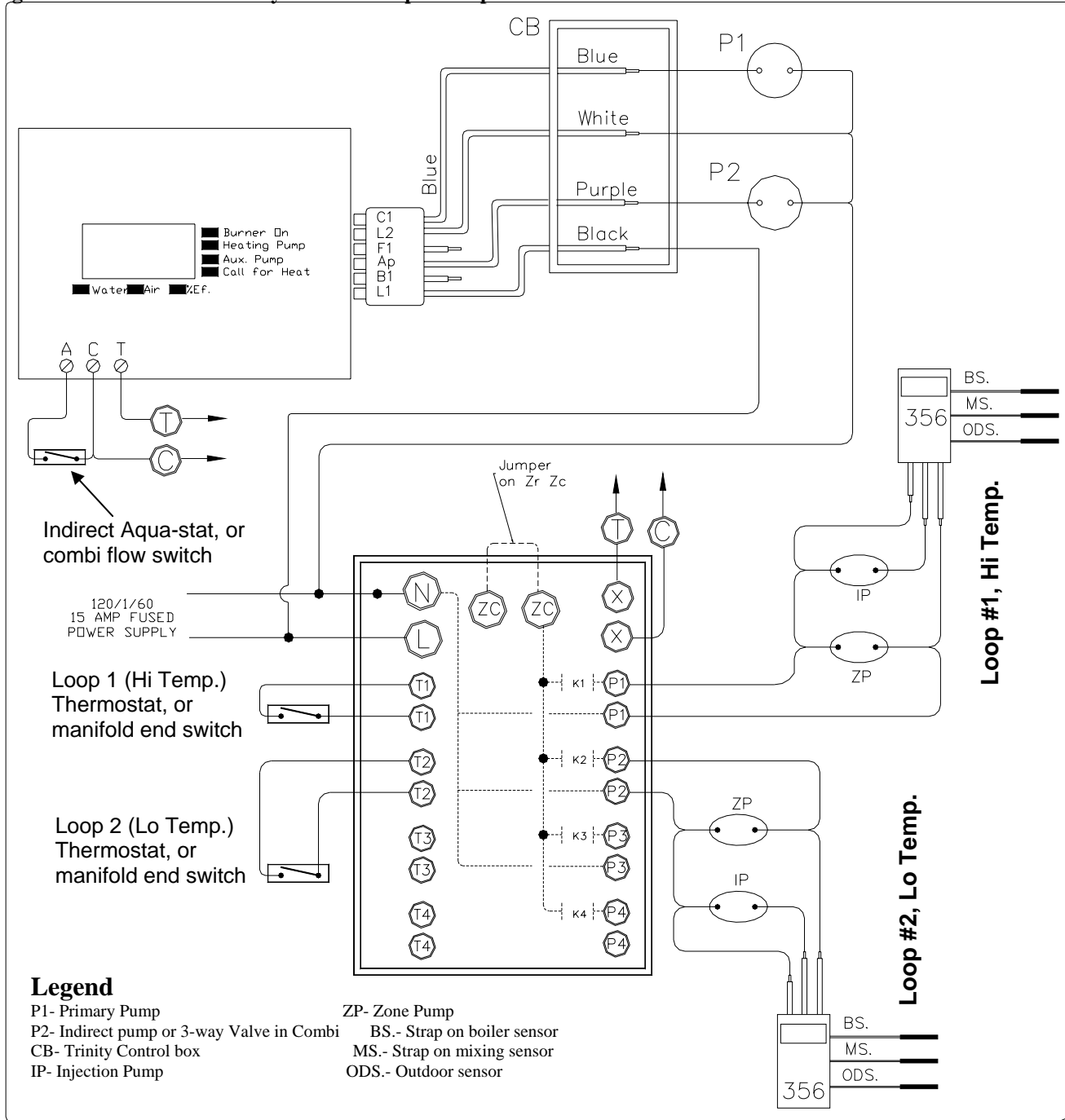

**Zone Circulator System – w/Multiple Temperatures**

Figure 10.6 illustrates a typical wiring configuration required for a heating system with multiple space heating temperature requirements. The example is of a system using two injection pumps controlled by two mixing controls. (Example shows a Taco model SR504 zone controller and two Tekmar 356 mixing controllers).

**Operation** - Room thermostat or the end switch of a zoned manifold closes the circuit to TT terminals of the zone controller. The zone controller:

1. Sends 120VAC to the applicable zone circulator (which circulates mixed water throughout the zone).
2. Sends 120 volts to the injection pump, through the Tekmar 356 mixing controller.
3. Closes the circuit between terminals T-C at the Trinity Ti Low Voltage field connection (See Table 10-2 and Figures 10-1 and 10-2). The Sentry 2100 provides power to the primary pump (P1) via the C1 (blue) pump output, see Table 10-1 and Figures 10-1 and 10-2. The controller then operates the burner to maintain the Space Heat set-point (HI), see Section 11.0.

The 356 controller reduces or increases the speed of the injection pump, depending on the temperature at the “Mix sensor”. Consult the Tekmar 356 installation manual for detailed installation, operation and set-up instructions.

## 11.0 SENTRY 2100 CONTROLLER

### CAUTION

The Sentry controller used on Ti400 is different than the Sentry controller used on Ti100-200 models. The T4.1 controller can only be used on Ti400's, while the T2.2 controller can only be used on Ti100-Ti200's)

The Sentry controller is the central controller for the Trinity boiler. The Sentry handles all the combustion logic, together with the energy management functions. The Sentry 2100 operates in two different modes, reset or conventional. The mode is automatically determined by the presence of the outdoor sensor. When the Sentry 2100 detects the presence of the outdoor sensor the controller will operate in Reset Mode, see Table 11-2. If the outdoor sensor is not installed, the controller will operate in Conventional Mode, see Table 11-1.

### Sentry 2100 Display

The following describes the meaning of the lights on the Sentry controller.

#### Green Lights:

- Burner/Bruleur** = Indicates that the ignition system is activated
- Circ.** = Indicates that the pump output C1 is activated (Boiler/Primary Loop Circulator).
- Circ. Aux.** = Indicates that the pump output Ap is activated (DHW Circulator for non-Combi, internal DHW diverter valve for Combi).
- Thermostat Demand** = Indicates that terminals T-C are closed, initiating a call for space heating.

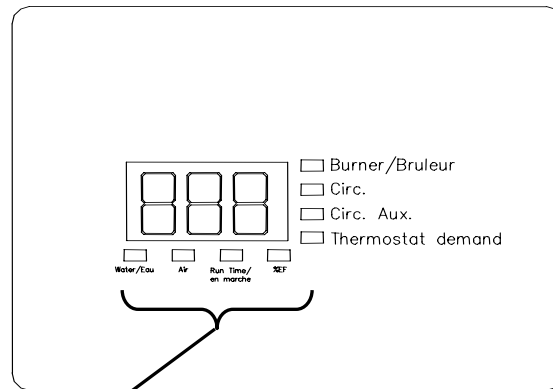

**Water Temp** – When illuminated, indicates that the display is showing boiler water temperature.

**Air** –When illuminated, indicates that the display is showing outdoor air temperature (only when outdoor air sensor is connected).

**Gas Input Value** – When illuminated, indicates the current input level (50-240 on Ti100-150, 40-240 on Ti200). See Chart to determine input.

**DHW Temp.** – When illuminated, indicates that terminals A-C are closed, initiating a demand for domestic hot water.

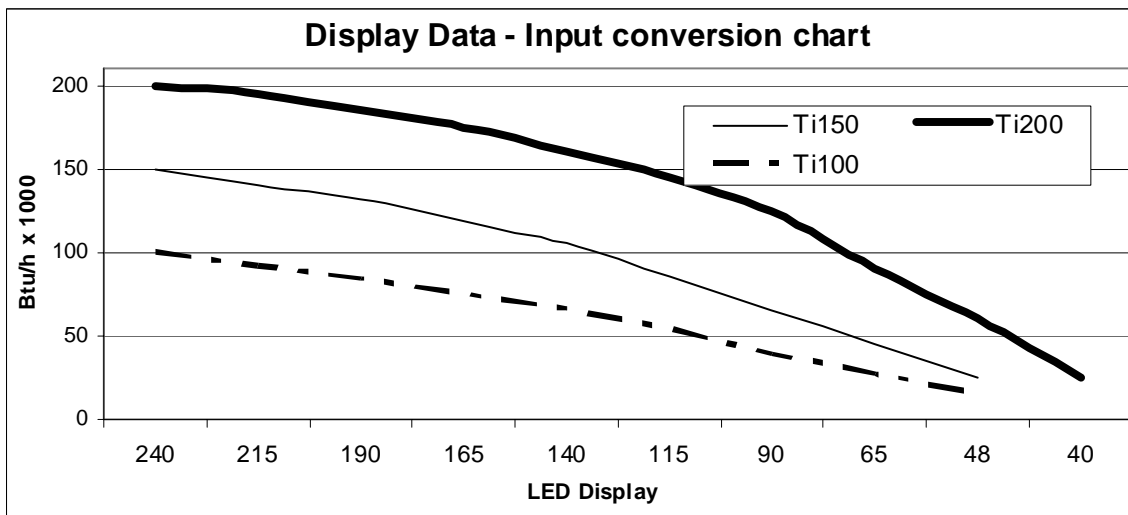

## Sentry 2100 Operation

The Trinity boiler employs a pneumatic modulation system. This modulation system increases or decreases the speed of the blower to meet the demand for heating. The gas valve senses this change in blower pressure, and introduces the required amount of gas to ensure correct combustion. The term “Set Point” is used to indicate the desired temperature that the Trinity will try and maintain, by increasing or decreasing the input.

Table 11-1 Sentry 2100 Operation – Conventional Mode

Condition	T-C & A-C Open (No Storage)	T-C Closed & A-C open	T-C Closed & A-C Closed	T-C Open & A-C Closed	T-C & A-C Open (Storage) <sup>Note 3</sup>
	Standby	Heating Only	Domestic Only	Domestic Only	Storage Mode
Set Point	-	HI	L0	L0	160°F
Burner On	-	HI – DIF	(LO-10) <sup>Note 4</sup>	(LO-10) <sup>Note 4</sup>	140°F
Burner Off	-	HI + 10	200°F	200°F	180°F
Circ – C1	Off	On	Off <sup>Note 1</sup>	Off <sup>Note 1</sup>	On
Aux. Circ – Ap	Off	Off	On <sup>Note 2</sup>	On <sup>Note 2</sup>	On

Table 11-2 Sentry 2100 Operation – Reset Mode

Condition	T-C & A-C Open	T-C Closed & A-C open	T-C Closed & A-C Closed	T-C Open & A-C Closed	T-C & A-C Open (Storage) <sup>Note 3</sup>
	Standby <sup>Note 3</sup>	Heating Only	Domestic Only	Domestic Only	Storage Mode
Set Point	-	HI <sub>Calc.</sub>	L0	L0	160°F
Burner On	-	HI <sub>Calc.</sub> – DIF	(LO-10) <sup>Note 4</sup>	(LO-10) <sup>Note 4</sup>	140°F
Burner Off	-	HI <sub>Calc.</sub> + 10	200°F	200°F	180°F
Circ – C1	Off	On	Off <sup>Note 1</sup>	Off <sup>Note 1</sup>	On
Aux. Circ – Ap	Off	Off	On <sup>Note 2</sup>	On <sup>Note 2</sup>	On

### Notes:

- 1- For Combi units the pump output C1 (Circ - C1) is powered for both space heating and domestic hot water demands, see Table 10-1 and Figure 10-2.
- 2- For Combi units the pump output Ap (Aux. Circ - Ap) powers the 3-way diverter valve located in the boiler, see Table 10-1 and Figure 10-2.
- 3- Combi units only, unit cycles on temperature (140-180°F) for 1 to 24 hours (StO setting) after last domestic hot water call, unless StO is set to OFF. **NOTICE:** Primary pump will run during Storage (StO) operation.
- 4- For Combi units the burner turns on when the water temperature is less then 190°F on the initial call, afterwards it turns back on when water temperature is less then LO set point.

## Setting the Sentry 2100

Programming is accomplished by a series of three push buttons located on the bottom side of the control. (*Function*,  $\uparrow$  and  $\downarrow$ ). To enter the programming mode, press the function key once. To scroll through the various menu options depress  $\uparrow$  until the desired menu item is displayed. To alter the value press *Function* once, and the current value will be displayed, then use  $\uparrow$  for up, and  $\downarrow$  for down, until the desired value is obtained. To enter the selected value press *Function*, which will return to the menu. When all desired values are selected, scroll to the RUN menu, and press *Function*, which exits the Programming Mode and initiates normal operation.

## Sentry 2100 Menu

**Table 11-3 Sentry 2100 Program Menu**

Menu Item	Settable Range	Description	Typical Settings
RUN		<b>Program Mode</b> - When Run is displayed, controller is in 'Prog' mode. Arrow up or down to scroll through menu items.	NA
LO	80-190°F	<b>DHW Set Point</b> - Boiler temperature the control attempts to maintain during a domestic hot water call (A-C circuit closed).	160°F
HI	80-200°F	<b>Central Heating Set Point</b> - Boiler temperature the control attempts to maintain during a heating call (T-C circuit closed). Note: the domestic call takes priority over the heating call.	140-160°F (Fan Coil) 170-190°F (Baseboard) 100-120°F (Low temperature Infloor)
DIF	1-40	<b>Differential Setting</b> - Applies only to a heating call. Temperature difference below set point at which burner will re-light.	20
RES	70-HI	<b>Sets Outdoor Reset Curve Slope</b> - The temperature where the boiler water set-point (heat call only) equals the outdoor temperature. I.e., if RES is set to 70, then the heating set point becomes 70 when it is 70°F outdoors or higher. (Only used if outdoor sensor is connected)	See Table 11-4
SFS	75-100	<b>Starting Gas Input Value</b>	85
HFS	100-240	<b>Maximum Gas Input Value</b>	240
LFS	40-100	<b>Minimum Gas Input Value</b>	50 for Ti100-150 40 for Ti200
ER5	ON/OFF	<b>DHW Time-Out</b> - When turned ON removes priority from DHW call after 2.5 hours; prioritizes heating call.	ON
FRE	ON/OFF	<b>Freeze Protection</b> - When turned ON the control operates the burner and the circulator once the boiler water temperature drops below 40°F. <b>WARNING</b> this is not a guarantee protection from freeze-up.	ON (if boiler controls primary circulator)
StO	OFF-24	<b>Storage Feature Timer</b> - Length of time in hours storage feature will keep boiler hot after the latest DHW call, only active on Combi boilers.	2 (turn OFF if Combi boiler utilizes a storage tank)

*To start the control operation, you must return to RUN in the menu, and press Function. Normal operation will begin. (\*Note: LFS must not be set below 50 on Ti100-150's.)*

## Outdoor Sensor (10K)

To fully take advantage of the energy saving features of the Trinity boiler, it is necessary to install the outdoor sensor provided. Install the sensor preferably on the north, or coldest side of the building, not within 10 feet of the discharge of the gas vent outlet, or other sources of heat. The outdoor sensor connects to the top of the boiler on terminals O and D.

## Calculating Outdoor Reset Curve (RES)

### Formula:

$$\text{Operating Temperature (HI}_{\text{CALC.}}) = \{(\text{RES} - \text{Outdoor Temp}) \times (\text{HI} - \text{RES}) / \text{RES}\} + \text{RES}$$

### Example:

- There is a call for heat and no call for domestic hot water (T-C closed & A-C open), the control uses the programmed HI and RES settings and the current outdoor temperature.
- The HI is programmed to be 160°F.
- The RES is programmed to be 85°F.
- The outdoor temperature is 40°F.

$$\text{Operating Temperature} = \{(85 - 40) \times (160 - 85) / 85\} + 85 = \underline{125^\circ\text{F}}$$

The following chart illustrates the effect of changing outdoor temperature on the boiler operating temperature for the above example.

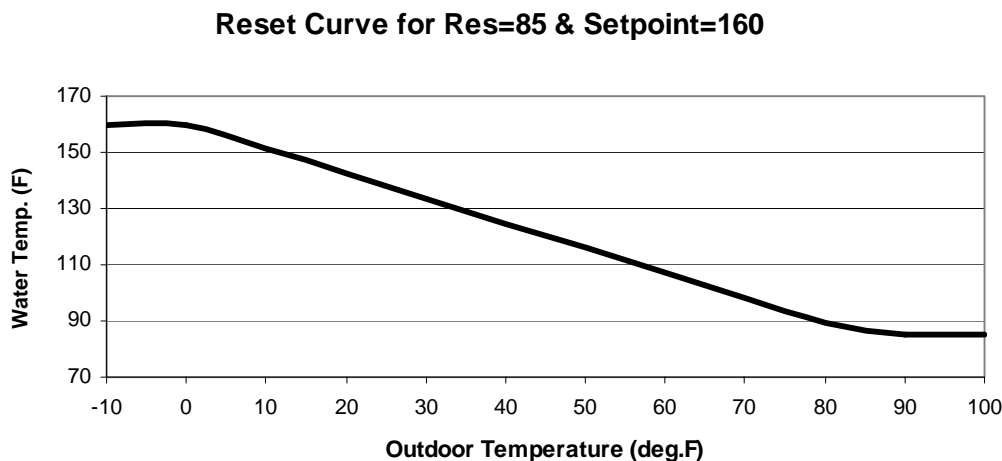

**Table 11-4 Low Voltage Field Connections**

Boiler Set Point – HI	Outdoor Reset – RES
80 – 110	70 – 80
110 – 140	80 – 90
140 – 170	90 – 100
170 – 200	100 – 110

## 12.0 TROUBLE SHOOTING

This section is intended to assist the service technician in detecting and correcting common errors. The Sentry 2100 is equipped with an internal diagnostic system that verifies control operation. The following series of error codes has been developed to aid in diagnosing control problems:

Problem	Detected Problem	Solution
<b>ER1</b> On Display	<b>“Water Temperature Excessive”</b> Sentry has sensed a water temperature in excess of 250°F at the water temperature thermister.	<ol style="list-style-type: none"> <li>1. If the boiler is extremely hot check for adequate water pressure and circulation, contact NTI for assistance.</li> <li>2. If not hot, check for sources of grounding or shorting (i.e. water) at the thermister electrical connections, check wiring from Sensor to Sentry Control.</li> <li>3. Replace thermister if the resistance is not in the correct range. (See resistance charts for 1 M-Ohm Trinity Thermister)</li> </ol>
<b>ER2</b> On Display	<b>“Water Temperature Thermister Short Circuit”</b> Sentry has sensed a short circuit in the water temperature thermister circuit.	See ER1.
<b>ER3</b> On Display	<b>“Water Sensor Open Circuit”</b> Sentry has sensed an open circuit in the Water Sensor circuit.	<ol style="list-style-type: none"> <li>1. Check wiring to Water Sensor for open circuits or shorting to ground (i.e. water). (Note: ER3 will be displayed if temperature sensed is less than 0°F.)</li> <li>2. Replace Water Sensor if the resistance is not in the correct range. (See resistance charts for 1 M- Ohm Trinity Thermister)</li> </ol>
<b>ER4</b> On Display	<b>“24V Limit Error”</b> Sentry has sensed a lack of 24V on the outlet of the Sentry burner relay (B1).	<p>The error locks the boiler out for one hour before retrying ignition.</p> <ol style="list-style-type: none"> <li>1. Reset power, if error goes away the problem is intermittent and was likely caused by a tripped limit that has automatically reset, check for adequate water pressure and flow rate. Allow the boiler to cycle and verify proper operation including outlet water temperature and flue temperature. If operation is unsuccessful and the error reoccurs continue to step 2.</li> <li>2. Ti100-200's are equipped with a low water pressure switch on the boiler return that requires a minimum of 10PSI to complete the 24VAC ignition circuit. Ensure there is a minimum of 15PSI on the boiler outlet prior to the primary circulator; ensure the boiler is plumbed in primary-secondary fashion. Replace water pressure switch if plumbing and pressure is correct and if it measures an open circuit.</li> <li>3. Check for continuity through the 24VAC limit wiring and manifold and stack limits, replace limits or wiring that are not a closed circuit.</li> </ol>
<b>ER5</b> On Display	<b>“DHW Time-Out”</b> The ER5 option is ON and the Sentry has sensed that the DHW call has lasted longer than 2.5 hours, thus removing priority from the DHW call.	<p>Reset the ER5 error by resetting the power or cycling the DHW call. Check for proper operation of the DHW call.</p> <ol style="list-style-type: none"> <li>1. Combi's are equipped with a DHW flow switch; ensure it is not sticking in the closed position when there is no DHW flow. If so, remove it and free it of any debris and check for proper operation, replace if necessary.</li> <li>2. For non-Combi boilers, operating with an indirect water heater, check for proper boiler water circulation during a DHW call, and check for proper operation of the indirect water heater's Aqua-stat.</li> <li>3. For applications with prolonged DHW draws, turn the ER5 option OFF.</li> </ol>
<b>ER6</b>	<b>“Flame Lock Out”</b> Sentry has sensed a lack of 24V to the gas valve during operation or a Fenwal ignition lockout.	<p>There is a problem in the ignition sequence, it could be caused by a faulty igniter, flame sensor, gas valve or improper line pressure or combustion. Check ignition sequence to determine which component is not functioning. <i>(Sentry will retry ignition sequence 1 hour after ER6 code originally occurs or if control is reset)</i></p> <p>If a 3-Flash error occurs on the Fenwal controller prior to locking out on an Er6, proceed to “Three Flashes on Fenwal”.</p>
<b>Burner shuts off before set-point temperature is reached</b> (and burner light goes out)	Reset calculation being used to lower HI setting.	If OD probe is being used, the HI setting will be calculated using formula in Section 11.0, adjust RES setting as necessary.
	Thermostat is satisfied	<ol style="list-style-type: none"> <li>1. If the thermostat demand light is turning off, the thermostat has satisfied.</li> <li>2. If DHW temp light is turning off; the Aqua-stat or call for DHW has been satisfied.</li> </ol>

<b>ER9</b>	<b>Internal Controller Fault</b>	Indicates that the Sentry control has lost communication with an internal processor, contact NTI for assistance.
<b>ASO Indicates that the Air Switch is Open</b>	<b>“Air Switch Open”</b>  This is displayed when the boiler is expecting the air switch to be closed by a differential pressure generated when the combustion blower turns on.	<ol style="list-style-type: none"> <li>1. Are the vinyl tubes connected between the air switch and the ports on the inlet pipe? Negative side of switch connects to the port on the 1-1/2” PVC elbow.</li> <li>2. Check for blockage on the intake and exhaust vents.</li> <li>3. If fan is running the air switch may be faulty, ensure it is set at 0.2”wc.</li> <li>4. If fan is not running, check 120V wiring to blower, if ok remove low voltage harness from blower, if blower fails to start, replace blower, if blower does start problem may be with blower or Sentry control.</li> </ol>
<b>ASC Indicates that the Air Switch is Closed</b>	<b>“Air Switch Closed”</b>  This is displayed when the boiler has turned the blower off and is expecting the air switch to be open.	<ol style="list-style-type: none"> <li>1. Is the fan running. If so check for 24V between B and D terminals (see wiring diagram). If 24V is not present replace transformer.</li> <li>2. If fan is not running then the Air Switch is stuck closed. <ol style="list-style-type: none"> <li>a. Check to ensure switch is set at 0.2”wc.</li> <li>b. Check vinyl tubes to air switch for moisture, clear if necessary and check venting termination for proper clearance (moisture in tubes is generally cause by cross-contamination of the exhaust to the air inlet).</li> <li>c. Remove the white wire from the air switch, if ASC persists replace the Sentry 2100 controller, if an ASO message is display replace the air switch.</li> </ol> </li> </ol>
<b>Two Flashes on Fenwal</b>	<b>“Flame Fault”</b>  The Fenwal controller senses flame prior to ignition sequence.	If the combustion sequence is normal, and there is no flame prior to ignition, the Fenwal control is defective, and must be replaced.
<b>Three Flashes on Fenwal</b>	<b>“Ignition Lockout”</b>	<p>Check the condensate drain for blockage – a blocked condensate drain will flood the combustion chamber and cause this error, see Section 4.0 for further instructions. Reset and observe ignition sequence:</p> <ol style="list-style-type: none"> <li>1. If the burner ignites then goes out within 2-3 seconds: <ol style="list-style-type: none"> <li>a. If the boiler is newly installed, check the polarity of the 120VAC power supply – reversed polarity will cause this error.</li> <li>b. Ensure the cable is connected to the flame sensor.</li> <li>c. Check for proper sustained gas line pressure.</li> <li>d. Check venting and combustion chamber for blockage – clean combustion chamber.</li> <li>e. Replace flame probe.</li> <li>f. Replace Fenwal controller.</li> </ol> </li> <li>2. If the igniter glows but the burner does not ignite: <ol style="list-style-type: none"> <li>a. Check for proper sustained gas line pressure.</li> <li>b. Check venting and combustion chamber for blockage – clean combustion chamber.</li> <li>c. Replace igniter.</li> <li>d. Replace Fenwal controller.</li> </ol> </li> <li>3. If the igniter does not glow: <ol style="list-style-type: none"> <li>a. Replace igniter.</li> <li>b. Replace Fenwal controller.</li> </ol> </li> </ol>
<b>Boiler will not stay lit.</b>	Indicates lack of a flame signal. In order to stay running the flame signal must be at least 0.7 $\mu$ Amps	<ol style="list-style-type: none"> <li>1. If the Burner light on the Sentry is going out, go to <b>“Burner shutting off”</b>.</li> <li>2. Check the condensate drain for blockage – a blocked condensate drain will flood the combustion chamber and cause this error, see Section 4.0 for further instructions.</li> <li>3. See Step 1 (a through f) under “Three Flashes on Fenwal”.</li> </ol>
<b>Boiler bangs or hisses</b>	Bangs or sounds like a kettle while burner is running indicates insufficient flow	<ol style="list-style-type: none"> <li>1. Ensure the plumbing is installed as per this manual. Check to see if pumps are operating properly and water pressure is above 15psi. <b>This problem can lead to boiler overheating!</b> See Section 8.0.</li> <li>2. Boiler may be plugging-up with scale or magnetite, clean with Fernox DS-40 Descaler and Cleaner (NTI PN: 83450).</li> <li>3. If glycol is being used the concentration may be to high, recommend using a concentration lower then 35%. De-rate unit by reducing the maximum modulation rate (HFS) and/or the maximum water temperature (LO and HI), see Section 11.0.</li> </ol>

<b>Boiler Lights rough or pulsates</b>	Typically an imbalance in the Air to gas ratio	<ol style="list-style-type: none"> <li>1. Ensure the vent lengths are in compliance with Section 3.0.</li> <li>2. Check venting and combustion chamber for blockage – clean combustion chamber.</li> <li>3. Check for proper sustained gas line pressure.</li> <li>4. Momentarily remove the intake pipe from the boiler during ignition, if unit lights smoothly with intake pipe disconnected reconnect and check for proper combustion, see Section 7.0.</li> </ol>
<b>Fan appears to be creating a noise in the house</b>	Slight vibration can cause noise in the residence (This is not a warranty issue)	Use flexible gas line to insolate the vibration noises between the gas valve and the line. Don't hang gas lines from floor joists. Use rubber insulators with gas line supports.
	Making a rubbing noise. ((This is not a warranty issue))	If gas valve is not held when the gas nipple is connected, the force of tightening the fitting can damage the valve, and warp the fan housing. If pipe is used, the gas line must not create any forces to the valve, either vertically (weight of line), or horizontally (misaligned connection)
<b>Display Goes Blank</b>	No power to control, blown control fuse or control failure	<ol style="list-style-type: none"> <li>1. Reset power, if display comes back on contact NTI for assistance.</li> <li>2. Ensure 120VAC is being supplied to the boiler.</li> <li>3. Check the internal fuse in the Sentry – to access the internal fuse, remove the front decal to reveal the screws securing the face plate cover. If fuse has blown replace with equivalent.</li> <li>4. Replace Sentry 2100 controller.</li> </ol>

The following are the resistance charts for diagnosing the water and outdoor air temperature thermisters of the Trinity boiler.

1. Measure the resistance of the thermister when disconnected.
2. Using the appropriate chart, find the resistance and move either vertical (Water Sensor) or horizontal (air probe) until the line is intersected.
3. Move 90 degrees to the corresponding temperature.
4. If the temperature is plus or minus 10 degrees, then the probe is operating correctly.

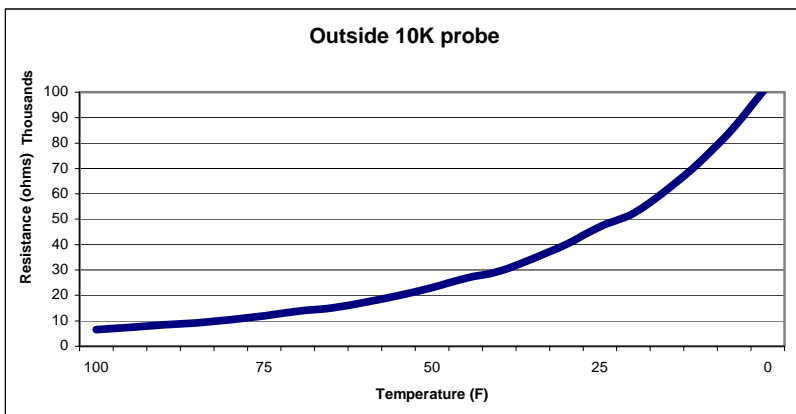
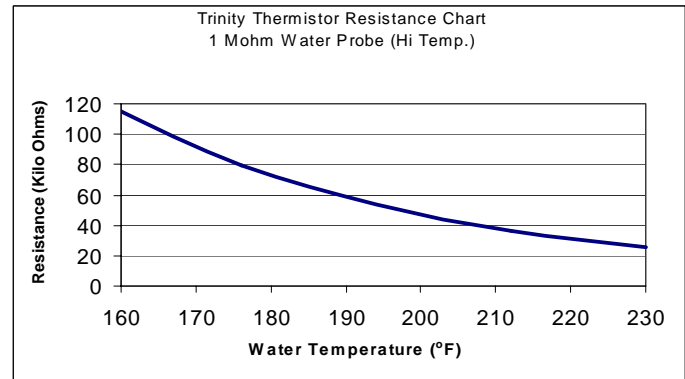
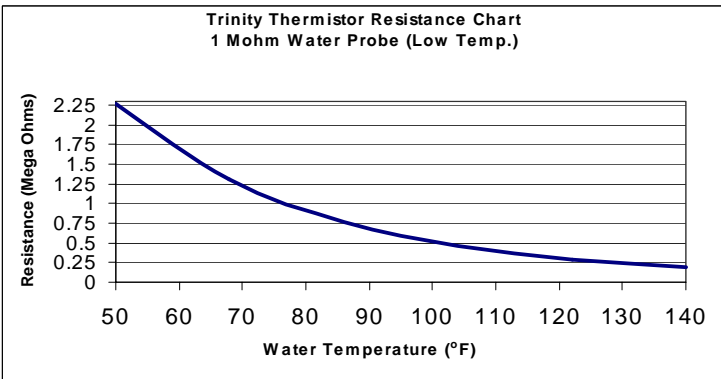

### 13.0 SEQUENCE OF OPERATION

The following is the normal sequence of operation for the trinity boiler.

### Trinity Sequence of operation

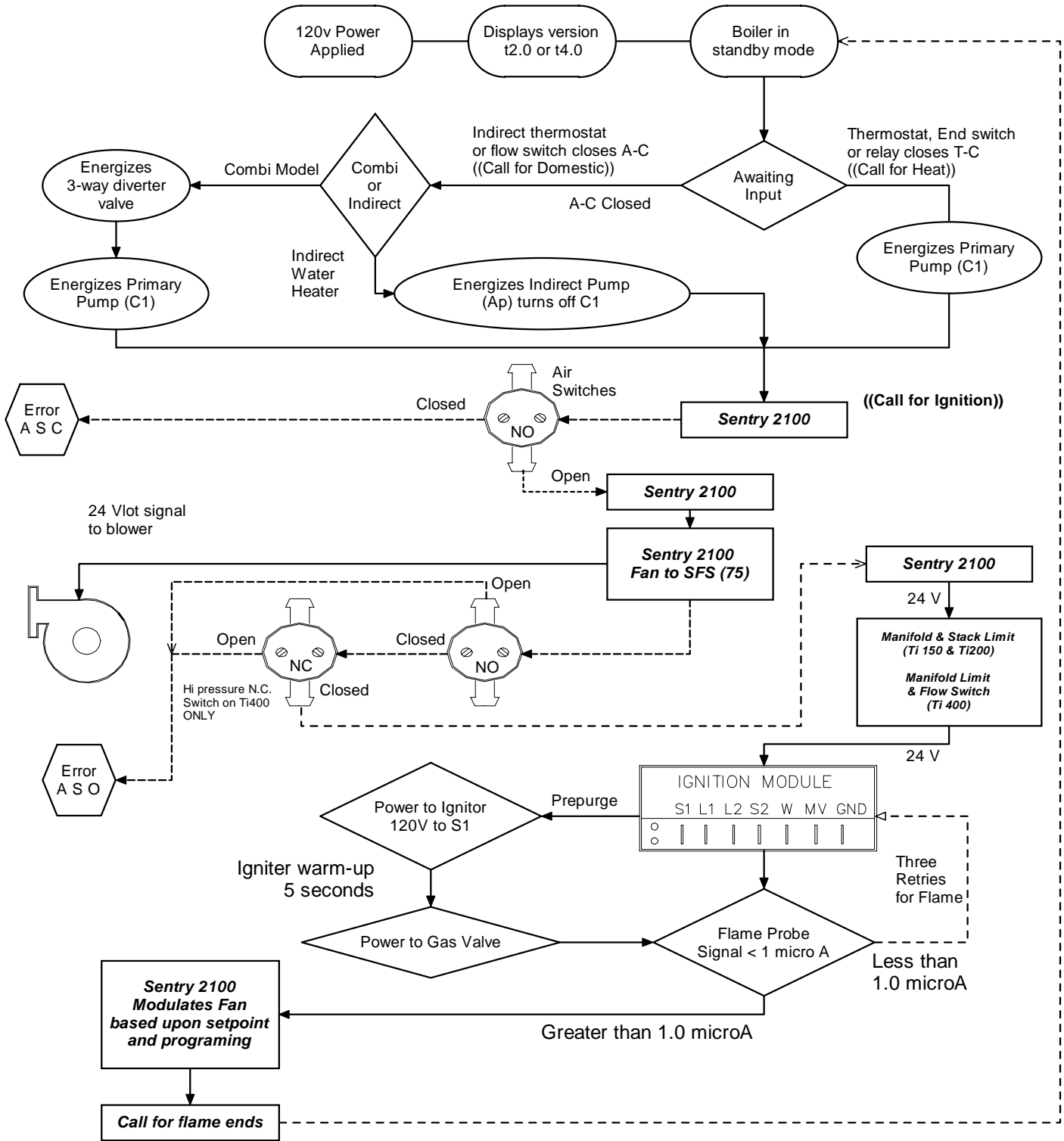



## 15.0 INSTALLATION CHECKLIST

### Installation

- 1. If operating on Propane Gas, convert appliance using kit number 82650-1.
- 2. Install the Vent/Air-Intake piping in accordance with Sections 3.0 of this manual. Ensure all joints are secured and cemented properly. Both the Vent and Air-Intake pipes must terminate outdoors. Perform the **Mandatory Pre-commissioning Procedure for Plastic Venting** in Section 3.0.
- 3. Connect the condensate drain in accordance with Section 4.0 of this manual.
- 4. Connect the gas supply in accordance with Section 5.0 of this manual.
- 5. Install the plumbing in accordance with the Section 8.0 of this Manual. Flush/clean the internals of the heating system (hydronic piping of hydronic systems only). Treat system water with Fernox F1 Protector.
- 6. Connect field wiring in accordance with Section 10.0 of this manual.
- 7. Advise home/building owner of their responsibilities with respect to maintaining the appliance.



The building owner is responsible for keeping the Vent/Air-Intake termination free of snow, ice, or other potential blockages and for scheduling routine maintenance on the appliance (see Section 16.0). Failure to properly maintain the appliance may result in serious injury or death.

### Start-up



Allow primers/cements to cure for 8 hours prior to Start-up. If curing time is less than 8 hours, first perform Steps 2 through 6 of **Mandatory Pre-commissioning Procedure for Plastic Venting** in Section 3.0. Failure to follow these instructions can result in explosion, serious injury or death.

- 1. Turn gas shut-off valve to the ON position.
- 2. Turn Power on to appliance.
- 3. Set Controller to the desired settings.
- 4. Turn thermostat up, Ignition will occur.

### Operational Checklist

- 1. System is free of gas leaks.
- 2. System is free of water leaks.
- 3. Water pressure is maintained above 15 PSI.
- 4. All air is purged from the heating system piping.
- 5. Ensure proper water flow rate; unit must not kettle, bang, hiss or flash the water to steam.
- 6. Ensure gas line pressure is in accordance with Section 5.0.
- 7. System is free of combustion leaks.
- 8. Unit must operate smoothly.
- 9. Ensure the flue gas combustion readings are within the tolerances listed in Table 7-1.
- 10. Each ignition must be smooth.
- 11. Verify that all condensate lines are clean and drain freely.

### Before Leaving

- 1. Remove line pressure gauge from gas valve, tighten bleed screw, test screw for leaks. See Section 7.0.
- 2. Ensure the condensate drain is assembled and working correctly, see Section 4.0.
- 3. Allow the appliance to complete at least one heating cycle, or to operate for at least 15 minutes.
- 4. Always verify proper operation after servicing.

### Instructions to Installing Contractor

- 1. Ensure that the customer receives the Warranty Documentation included with the installation manual.
- 2. Leave the manual with the customer so they know when to call for annual maintenance and inspection.



This appliance must have water flowing through it whenever the burner is firing. Failure to comply may damage the unit, void the warranty, and cause serious injury or death.



Allowing the appliance to operate with a dirty combustion chamber will adversely affect its operation and void the warranty. Failure to clean the heat exchanger on a frequency that matches the need of the application may result in fire, property damage, or death.

## 16.0 ANNUAL MAINTENANCE AND INSPECTION

This unit must be inspected at the beginning of every heating season by a Qualified Technician.

### Annual Inspection Checklist

- 1. Lighting is smooth and consistent, and the combustion fan is noise & vibration free.
- 2. The condensate freely flows from the unit, and is cleaned of sediment.
- 3. Relief Valve and air vents are not weeping.
- 4. Low water cut off is flushed (if applicable)
- 5. Examine all venting for evidence of leaks. Ensure vent screens are cleaned and clear of debris.
- 6. Check the burner plate for signs of leaking.
- 7. The combustion chamber must be inspected and cleaned (See Combustion Chamber Cleaning Procedure below).
- 8. Listen for water flow noises indicating a drop in appliance water flow rate.

**Important** - The hydronic system may need to be flushed to eliminate hard water scale (Use Fernox DS-40 Descaler, NTI PN: 83450).

### Combustion Chamber Cleaning Procedure

Units operating with LP Gas or in an industrial environment will have to be cleaned a minimum of once per year. Other applications will require the combustion chamber to be cleaned after the first year of operation, with subsequent cleanings scheduled based on the condition of the combustion chamber at the time. Unless a step is identified as model specific, the following combustion chamber cleaning procedure is the same for all models.



**Crystalline Silica** - Read carefully the warnings and handling instructions pertaining to Refractory Ceramic Fibers before commencing any service work in the combustion chamber. Take all necessary precautions and use recommended personal protective equipment as required.

- 1. Initiate a post-purge cycle to clear any gas from the combustion chamber, then turn gas valve off.
- 2. Access the combustion chamber by removing the aluminum burner door assembly of the appliance.
- 3. Remove the insulation disc (P/N 83112) located in the back of the combustion chamber to avoid damaging it during the cleaning process. The disc is held in place with a 2.5mm "Allen-head" screw.
- 4. Use a vacuum with a high efficiency filter to remove any loose debris or dust.
- 5. Wet the inside of the combustion chamber with water. Use a garden hose with a trigger nozzle to direct pressurized water through the gaps between the heat exchanger tubes. The water should pass in-between the heat exchanger tubes and exit via the condensate drain. This process may require the use of some dry rags or plastic to protect electrical components from being damaged by dripping or spraying water.
- 6. Use a nylon or other non-metallic brush to loosen the incrustations and any other contaminants that have remained stuck on and in-between the tubes.
- 7. Repeat steps 5 and 6 until the heat exchanger is clean and water from the condensate drain runs clear.
- 8. Re-install the insulation disc (part no. 83112) to the back of the combustion chamber.
- 9. Inspect the insulation disc located on the back-side of the burner door (p/n 82769). Replace if damaged.
- 10. Re-install the burner door, gas-supply and Air-inlet pipe, check for gas leaks.
- 13. Perform the Operational Check List detailed in Section 15.0.



Replace any gaskets or insulation discs that show any signs of damage and do not re-use. Failure to follow these instructions may result in fire, property damage or death.

## Refractory Ceramic Fibers (RFC)



**Personal Protective Equipment Recommended** - Read the following warnings and handling instructions carefully before commencing any service work in the combustion chamber. The insulating material on the inside of the burner door and at the back of the combustion chamber contain *Refractory Ceramic Fibers* and should not be handled without personal protective equipment.



**Potential Carcinogen** - Use of *Refractory Ceramic Fibers* in high temperature applications (above 1000°C) can result in the formation of Crystalline Silica (cristobalite), a respirable silica dust. Repeated airborne exposure to crystalline silica dust may result in chronic lung infections, acute respiratory illness, or death.

Crystalline silica is listed as a (potential) occupational carcinogen by the following regulatory organizations: International Agency for Research on Cancer (IARC), Canadian Centre for Occupational Health and Safety (CCOHS), Occupational Safety and Health Administration (OSHA), and National Institute for Occupational Safety and Health (NIOSH). Failure to comply with handling instructions in Table 16-1 may result in serious injury or death.



**Crystalline Silica** - Certain components confined in the combustion chamber may contain this potential carcinogen. Improper installation, adjustment, alteration, service or maintenance can cause property damage, serious injury (exposure to hazardous materials) or death. Refer to Table 16-1 for handling instruction and recommended personal protective equipment. Installation and service must be performed by a qualified installer, service agency or the gas supplier (who must read and follow the supplied instructions before installing, servicing, or removing this appliance. This appliance contains materials that have been identified as carcinogenic, or possibly carcinogenic, to humans).

Installation and service must be performed by a qualified installer, service agency or the gas supplier (who must read and follow the supplied instructions before installing, servicing, or removing this appliance. This appliance contains materials that have been identified as carcinogenic, or possibly carcinogenic, to humans).

**Table 16-1 Handling Instructions for Refractory Ceramic Fibers (RCF)**

Reduce the Risk of Exposure	Precautions and Recommended Personal Protective Equipment
Avoid contact with skin and eyes	<ul style="list-style-type: none"> <li>Wear long-sleeved clothing, gloves, and safety goggles or glasses.</li> </ul>
Avoid breathing in silica dust	<ul style="list-style-type: none"> <li>Wear a respirator with a N95-rated filter efficiency or better.<sup>1</sup></li> <li>Use water to reduce airborne dust levels when cleaning the combustion chamber.</li> <li>Do not dry sweep silica dust. Pre-wet or use a vacuum with a high efficiency filter.</li> </ul>
Avoid transferring contamination	<ul style="list-style-type: none"> <li>When installing or removing RFCs, place the material in a sealable plastic bag.</li> <li>Remove contaminated clothing after use. Store in sealable container until cleaned.</li> <li>Wash contaminated clothing separately from other laundry.</li> </ul>
First Aid Measures	<p>If irritation persists after implementing first aid measures consult a physician.</p> <ul style="list-style-type: none"> <li><b>Skin</b> - Wash with soap and water.</li> <li><b>Eyes</b> - Do not rub eyes; flush with water immediately.</li> <li><b>Inhalation</b> - Breathe in fresh air; drink water, sneeze or cough to clear irritated passage ways.</li> </ul>
<p><b>Notes:</b></p> <p><sup>1</sup> Respirator recommendations based on CCOHS and OSHA requirements at the time this document was written. Consult your local regulatory authority regarding current requirements for respirators, personal protective equipment, handling, and disposal of RCFs.</p>	

For more information on Refractory Ceramic Fibers, the risks, recommended handling procedures and acceptable disposal practices contact the organization(s) listed below:

**Canada (CCOHS):** Telephone directory listing under Government Blue Pages Canada—Health and Safety—Canadian Centre for Occupational Health and Safety; or website <http://www.ccohs.ca>.

**United States (OSHA):** Telephone directory listing under United States Government—Department of Labor—Occupational Safety and Health Administration; or website <http://www.osha.gov>.

## 17.0 PARTS LIST

### Models Ti100-Ti200

Replacement parts are available from your stocking wholesaler. Homeowners must contact their local Installer or Wholesaler. Installers or Wholesalers may contact NY Thermal Inc. for assistance at 506-657-6000. Notes: \*Used for Combi version only.

No.	P.N.	Description
1	82657	Premix burner, 135.8 Ti-150
1	82658	Premix burner, 200.6 Ti-200
1A	82761	Premix Burner Gasket
2	82457	Transformer, 24V
3	82013	Sentry 2100
4	82052	Blower #RG130 Ti-150 Only
4	82661	Blower #RG148 Ti-200 Only
5	82054	Gas Valve (CVI) VK8115F1134B
5A	82065	Gas Valve 1/2" npt elbow
5B	82600	Gas Valve Vent connection
6	82662	Air switch Huba @ .2"wc.
7	83035	Thermister 1/4"NPT
8	82058	Ignition Module (Fenwal)
9	82708	IGNITER, #601, c/w SS shield
10	82762	Rauschert Flame Rod
11	82763	Composite Flue Box
11A	82764	Composite Flue Box Gasket
11B	82765	Composite Flue Outlet Gasket
11C	83291-1	Flue Adapter Assembly (Ti100-200)
12	82992	Manifold Limit, 1/4NPT(Ti100-150 ASME)
13	82596	Ti100-150 Heat Exchanger
13	83012	Ti100-150 ASME Heat Exchanger
13	82647	Ti 200 Heat Exchanger
14	82650	LP orifice 5.20mm Ti150-200 Only
14	83216	LP orifice 3.40mm Ti100 Only
15	82660	Stack Limit, 1/4BSP,190F, Dif=30
16	82766	Blower gasket Ti100-150 Only
16	82719	Blower gasket Ti200 Only
17	82622-1	Ti Inlet Pipe assembly
18	83042	Condensate Y Drain
18A	82913	Siphon Condensate Trap
19	82767	Cast aluminum Burner door
19A	82769	Ti Ceramic burner door disc
19B	82770	Ti Burner door gasket
20	82768	Ti Igniter gasket
21	82228*	Tempering valve #AM101-US-1
22	82771	Extended air tube
23	82011*	Plate heat exchanger LA 1430
24	81896*	Flow switch FS-380, .5activate
25	82160*	3 way Valve VU54S2016B, 3/4"
26	82159*	3 way actuator VU444A1007B
27	82754	Control panel & Harness
27A	82754-1	PCB Optocoupler
28	82054-1	CVI Venturi 01 (Ti150 & 200)
28	83205	CVI Venturi 003 (Ti100 Only)
28A	82054-2	CVI Venturi Gasket
29	82104-1	Ti Air metering Elbow
30	81027-1	Sentry (10k) Outdoor Air Sensor
31	83223-1	Pressure Switch 1/4NPT (Ti100-150ASME)
32	83112	Divider plate insul (c/w washer & screw)
33	83462	Tee, Brass, 1/4"
34	82539	Auto Air Vent, 1/8"
35	83059	Terminal Strip
36	82411-3	Ti100-200 Cover

