



Trinity Lx600 High Efficiency Gas Condensing Boiler & Water Heater

Submittal Sheet

Section 1 - Specifications
Section 2 - Dimensions
Section 3 - Electrical

Project Name: _____ Date: _____
 Location: _____
 Engineer: _____
 Contractor: _____ Rep: _____

1 SPECIFICATIONS

General Specifications

- ▶ Product Features
 - Certified to ANSI Z21.13 / CSA 4.9 Gas-fired Boiler Standard
 - Certified to ANSI Z21.10.3 / CSA 4.3 Gas Water Heater Standard
 - ASME "H" stamped boiler, designed and constructed in compliance with the ASME Boiler and Pressure Vessel Code Section IV.
 - CSD-1 compliant
 - Maximum operating pressure 160 psi [1103 kPa]
 - Modulating burner, 5:1 turndown
 - Direct Spark Ignition
 - Zero clearance to combustibles
- ▶ Optional Side Wall Vent Terminal Kits NTI part # 83236, 84355, 84358
- ▶ Factory Supplied Items
 - 10k thermistor Outdoor and System sensors
- ▶ Factory Supplied Items (cont'd)
 - 2 - 500ml bottles Fernox F1 Protector
 - Flow switch
 - 50PSI & 150PSI ASME Relief Valves
 - 60PSI & 160PSI Pressure Gauge
- ▶ Control Features
 - Integral microprocessor safety control
 - 2 central heat inputs (high & low temperature)
 - Domestic Hot Water Priority
 - Outdoor reset
 - Warm weather shutdown
 - Time of day input
 - Lead-Lag up to 8 Lx series boilers

Water Connections NPT, in.	Gas Connection NPT, in.	Vent/Air-Intake Pipe Diameter in. [mm]	Vent/Air-Intake Max. Length ft. [m]	Approx. Weight with Water lb. [kg]
2	1	Air Inlet 4 [102]	100 [30.5]	380 [172]
		Vent 4 [102]	100 [30.5]	

Heating Specifications

Input		Heating Capacity BTU/hr [kW]	Recovery Rate @ 100°F Rise USGPH	Steady State Efficiency %
Min BTU/hr [kW]	Max BTU/hr [kW]			
120,000 [35.1]	600,000 [176]	562,000 [164]	677	94.0

Performance Specifications

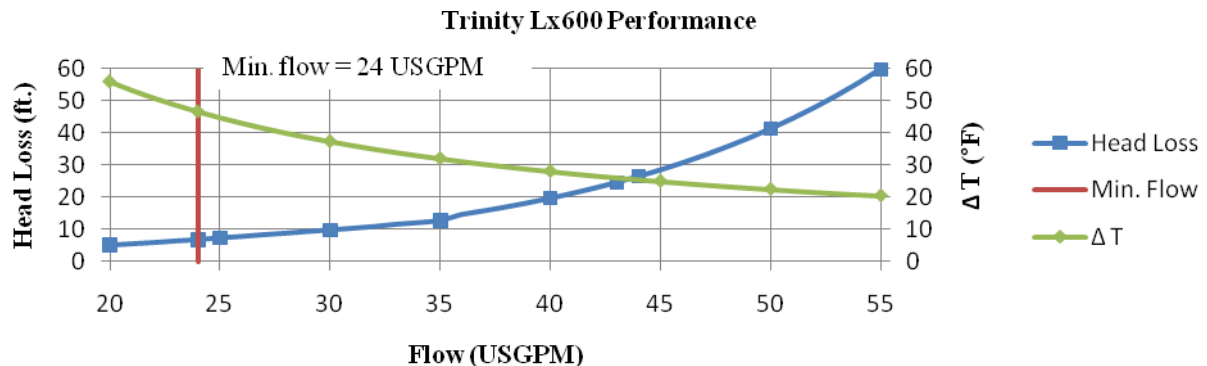

NY Thermal Inc.

65 Drury Cove Road Saint John, NB E2H 2Z8 Canada

Technical Service: 1-800-688-2575 Fax: 1-506-432-1135 Web: <http://www.nythermal.com>

NY Thermal Inc. reserves the right to change these specifications without notice



Trinity Lx600 High Efficiency Gas Condensing Boiler & Water Heater

Submittal Sheet

DIMENSIONS

Product Dimensions – in. [mm]

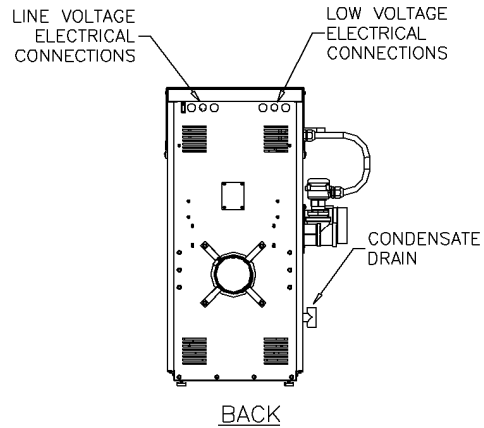
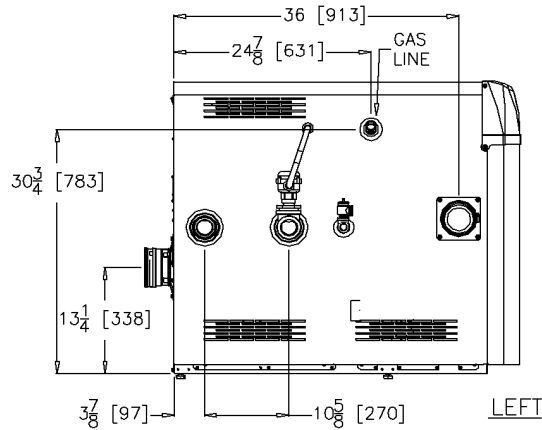
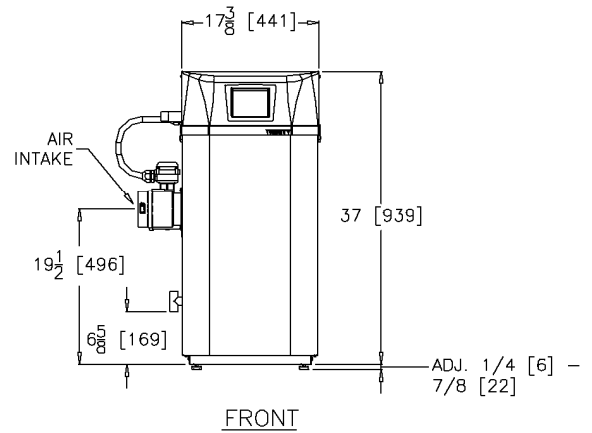
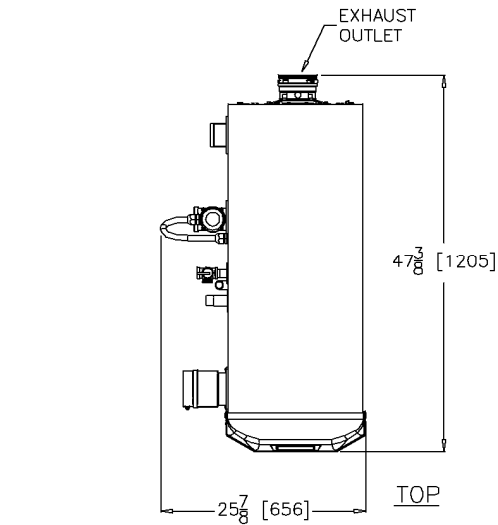

Recommended Clearances – in. [mm]

Top	Front	Left	Right	Back	Bottom
24 [610]	24 [610]	24 [610]	12 [305]	24	0



NY Thermal Inc.

65 Drury Cove Road Saint John, NB E2H 2Z8 Canada

Technical Service: 1-800-688-2575 Fax: 1-506-432-1135 Web: <http://www.nythermal.com>

NY Thermal Inc. reserves the right to change these specifications without notice



Trinity Lx600 High Efficiency Gas Condensing Boiler & Water Heater

Submittal Sheet

3 ELECTRICAL

Simplified Wiring Diagrams

Line Voltage Electrical:

- ▶ 120VAC / 60 Hz / 1 Phase / 12 Amp
- ▶ Barrier Strip for field wiring terminations
- ▶ 3 Pump outputs
 - Indirect Domestic Hot Water (Pump A)
 - Boiler (Pump B)
 - Central Heat (Pump C)

Note: Pumps are field supplied.

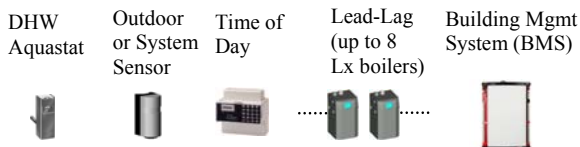
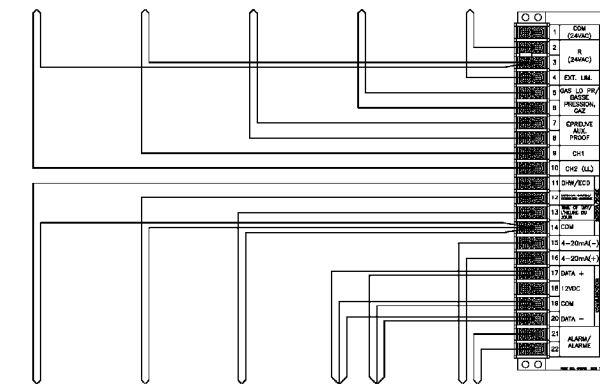
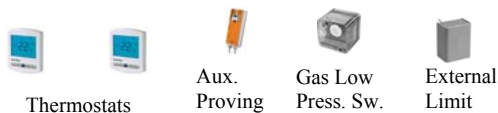
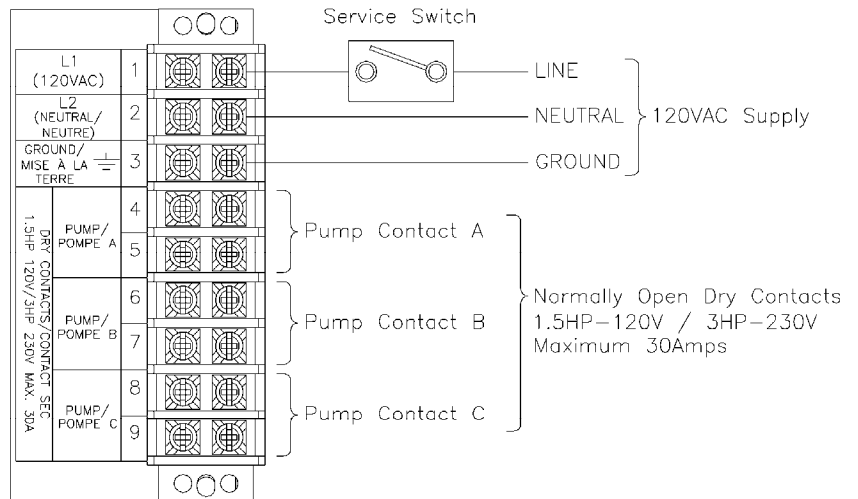

Low Voltage Electrical:

- ▶ Barrier Strip for field wiring terminations
- ▶ 120/24 VAC Transformer 75VA (factory supplied)
- ▶ Inputs
 - 2 CH thermostat inputs (by others)
 - Indirect DHW aquastat (by others)
 - External Limit (by others)
 - Gas low pressure switch (by others)
 - Outdoor sensor (factory supplied)
 - System sensor (factory supplied)
 - 4-20mA external modulating control (by others)
 - Time of day (TOD) (by others)
- ▶ Outputs
 - Remote Touchscreen display (optional)
 - Alarm dry contact (24VAC 0.63A max.)
- ▶ EIA-485 Modbus communications for Lead-Lag



NY Thermal Inc.

65 Drury Cove Road Saint John, NB E2H 2Z8 Canada

Technical Service: 1-800-688-2575 Fax: 1-506-432-1135 Web: <http://www.nythermal.com>

NY Thermal Inc. reserves the right to change these specifications without notice