



# Trinity Lx300 High Efficiency Gas Condensing Boiler & Water Heater

## Submittal Sheet

Section 1 - Specifications  
Section 2 - Dimensions  
Section 3 - Electrical

Project Name: \_\_\_\_\_ Date: \_\_\_\_\_  
 Location: \_\_\_\_\_  
 Engineer: \_\_\_\_\_  
 Contractor: \_\_\_\_\_ Rep: \_\_\_\_\_

### 1 SPECIFICATIONS

#### General Specifications

- ▶ Product Features
  - Certified to ANSI Z21.13 / CSA 4.9 Gas-fired Boiler Standard
  - Certified to ANSI Z21.10.3 / CSA 4.3 Gas Water Heater Standard
  - ASME “H” stamped boiler, designed and constructed in compliance with the ASME Boiler and Pressure Vessel Code Section IV.
  - Maximum operating pressure 160 psi [1103 kPa]
  - Field conversion from Natural Gas (factory) to Propane
  - Modulating burner, 5:1 turndown
  - Direct Spark Ignition
  - Wall or floor mounting
  - Zero clearance to combustibles
- ▶ Optional Side Wall Vent Terminal Kit (NTI Part # 83236, 84355 & 84358)
- ▶ Factory Supplied Items
  - 1 – 500ml bottle Fernox F1 Protector
  - 10k thermistor Outdoor and System sensors
  - 30PSI & 125PSI ASME Relief Valves
  - 30PSI & 160PSI Pressure Gauges
- ▶ Control Features
  - Integral microprocessor safety control
  - 2 central heat inputs (high & low temperature)
  - Domestic Hot Water Priority
  - Outdoor reset
  - Warm weather shutdown
  - Lead-Lag up to 8 Lx series boilers

Water Connections NPT, in.	Gas Connection NPT, in.	Vent/Air-Intake Pipe Diameter in. [mm]	Vent/Air-Intake Max. Length, NG/LP ft. [m]	Approx. Weight with Water lb. [kg]
1-1/4	1/2	4 [102]	100 [30.5]	180 [81.6]
		6 [152]	100 [30.5]	

#### Heating Specifications

Input		Heating Capacity BTU/hr [kW]	Recovery Rate @ 100°F Rise USGPH	AFUE %	Net I=B=R Rating BTU/hr [kW]
Min BTU/hr [kW]	Max BTU/hr [kW]				
55,000 [16.1]	275,000 [80.5]	251,000 [73.5]	310	95.1	213,000 [62.4]

#### Performance Specifications

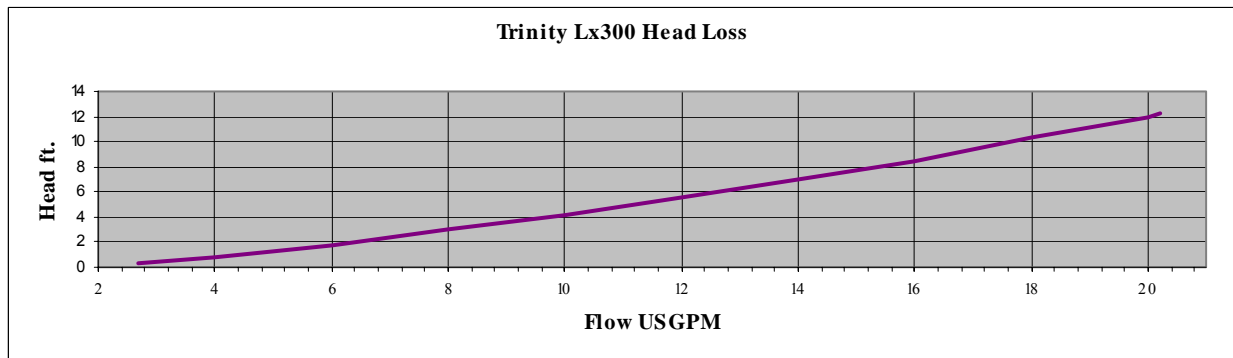

NY Thermal Inc.

65 Drury Cove Road Saint John, NB E2H 2Z8 Canada

Technical Service: 1-800-688-2575 Fax: 1-506-432-1135 Web: <http://www.nythermal.com>

NY Thermal Inc. reserves the right to change these specifications without notice



# Trinity Lx300 High Efficiency Gas Condensing Boiler & Water Heater

## Submittal Sheet

### 2 DIMENSIONS

#### Product Dimensions – in. [mm]

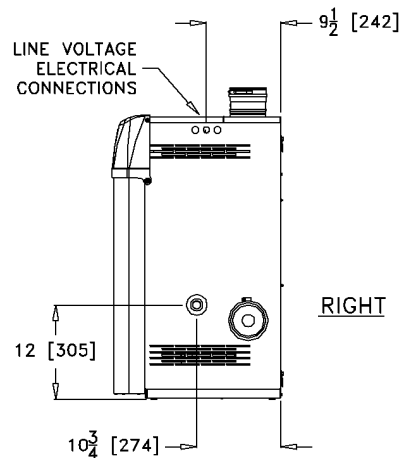
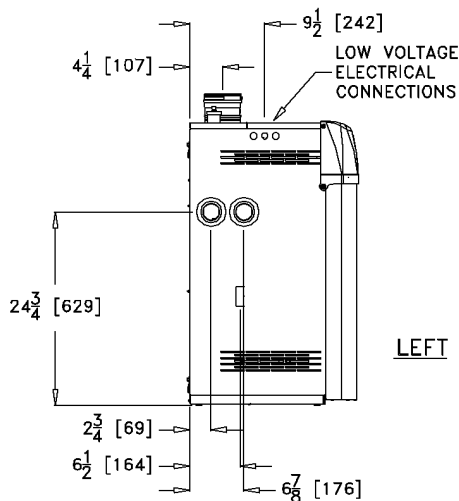
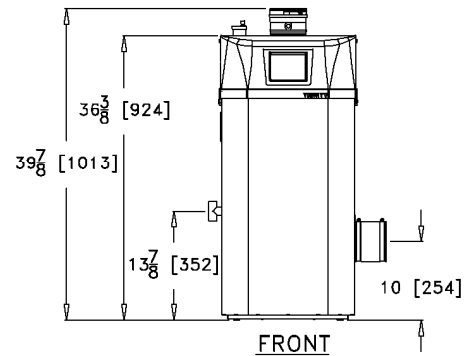
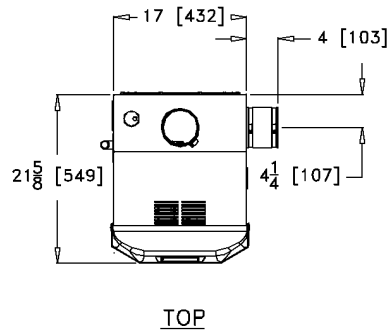

#### Recommended Clearances – in. [mm]

Top	Front	Left	Right	Back	Bottom
24 [610]	24 [610]	24 [610]	12 [305]	0	0



NY Thermal Inc.

65 Drury Cove Road Saint John, NB E2H 2Z8 Canada

Technical Service: 1-800-688-2575 Fax: 1-506-432-1135 Web: <http://www.nythermal.com>

NY Thermal Inc. reserves the right to change these specifications without notice



# Trinity Lx300 High Efficiency Gas Condensing Boiler & Water Heater

## Submittal Sheet

### 3 ELECTRICAL

#### Simplified Wiring Diagrams

##### Line Voltage Electrical:

- ▶ 120VAC / 60 Hz / 1 Phase / 12 Amp
- ▶ Barrier Strip for field wiring terminations
- ▶ 3 Pump outputs
  - Indirect Domestic Hot Water (Pump A)
  - Boiler (Pump B)
  - Central Heat (Pump C)

Note: Pumps are field supplied.

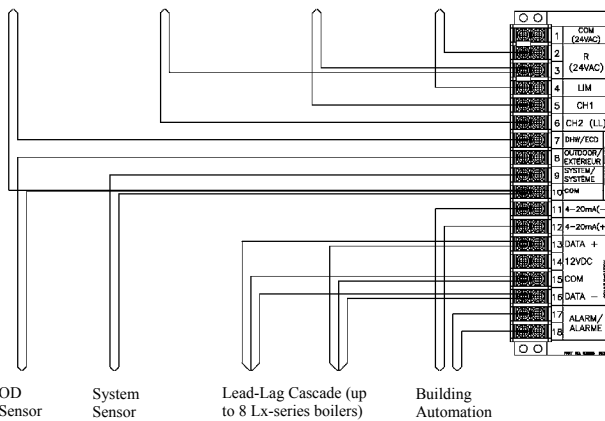
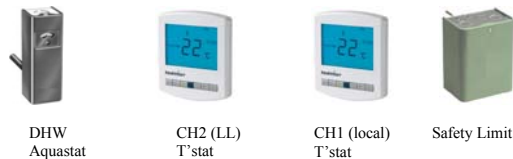
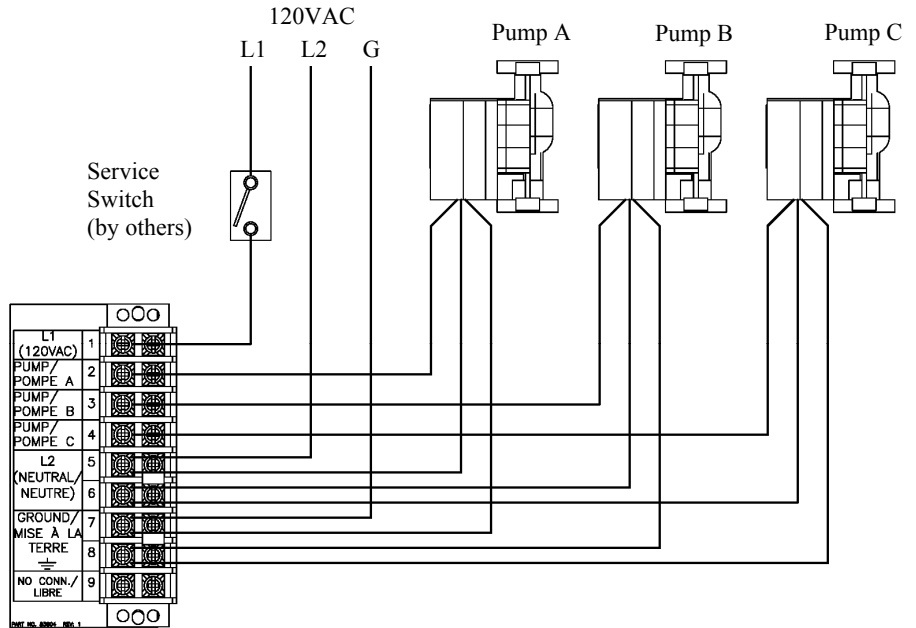

##### Low Voltage Electrical:

- ▶ Barrier Strip for field wiring terminations
- ▶ 120/24 VAC Transformer 40VA (factory supplied)
- ▶ Inputs
  - CH1 thermostat (by others)
  - CH2 thermostat (by others)
  - Indirect DHW aquastat (by others)
  - External Limit (by others)
  - Outdoor sensor (factory supplied)
  - System sensor (factory supplied)
  - 4-20mA external modulating control (by others)
- ▶ Outputs
  - Remote Touchscreen display (optional)
  - Alarm dry contact (24VAC 0.63A max.)
- ▶ EIA-485 Modbus communications for Lead-Lag



NY Thermal Inc.

65 Drury Cove Road Saint John, NB E2H 2Z8 Canada

Technical Service: 1-800-688-2575 Fax: 1-506-432-1135 Web: <http://www.nythermal.com>

NY Thermal Inc. reserves the right to change these specifications without notice