



Trinity Lx200 High Efficiency Gas Condensing Boiler & Water Heater

Submittal Sheet

Section 1 - Specifications
Section 2 - Dimensions
Section 3 - Electrical

Project Name: _____ Date: _____
 Location: _____
 Engineer: _____
 Contractor: _____ Rep: _____

1 SPECIFICATIONS

General Specifications

► Product Features

- Certified to ANSI Z21.13 / CSA 4.9 Gas-fired Boiler Standard
- Certified to ANSI Z21.10.3 / CSA 4.3 Gas Water Heater Standard
- ASME "H" stamped boiler, designed and constructed in compliance with the ASME Boiler and Pressure Vessel Code Section IV.
- Maximum operating pressure 145 psi [1000 kPa]
- Field conversion from Natural Gas (factory) to Propane
- Modulating burner, 8:1 turndown
- Direct Spark Ignition
- Wall or floor mounting
- Zero clearance to combustibles

► Optional sidewall vent kit (NTI part # 82666 & 84357)

► Factory Supplied Items

- 1 – 500ml bottle Fernox F1 Protector
- 10K thermistor outdoor and system sensors
- 30PSI & 125PSI ASME Relief Valves
- 30PSI & 160PSI Pressure Gauges

► Control Features

- Integral microprocessor safety control
- 2 central heat inputs (high & low temperature)
- Domestic Hot Water Priority
- Outdoor reset
- Warm weather shutdown
- Lead-Lag up to 8 Lx series boilers

Water Connections NPT, in.	Gas Connection NPT, in.	Vent/Air-Intake Pipe Diameter in. [mm]	Vent/Air-Intake Max. Length, NG/LP ft. [m]	Approx. Weight with Water lb. [kg]
1	1/2	3 [76]	105 / 50 [32 / 15.2]	125 [56.7]

Heating Specifications

Input		Heating Capacity BTU/hr [kW]	Recovery Rate @ 100°F Rise USGPH	AFUE %	Net I=B=R Rating BTU/hr [kW]
Min BTU/hr [kW]	Max BTU/hr [kW]				
25,000 [7.3]	199,000 [58.3]	182,000 [53.3]	224	95.1	158,000 [46.3]

Performance Specifications

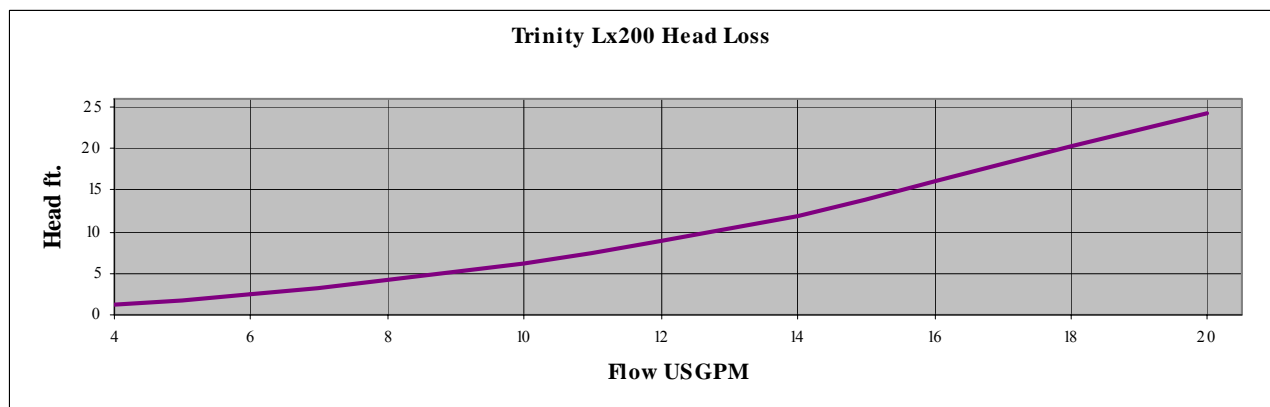

NY Thermal Inc.

65 Drury Cove Road Saint John, NB E2H 2Z8 Canada

Technical Service: 1-800-688-2575 Fax: 1-506-432-1135 Web: <http://www.nythermal.com>

NY Thermal Inc. reserves the right to change these specifications without notice



**Trinity Lx200
High Efficiency Gas
Condensing Boiler & Water Heater**

Submittal Sheet

2 DIMENSIONS

Product Dimensions – in. [mm]

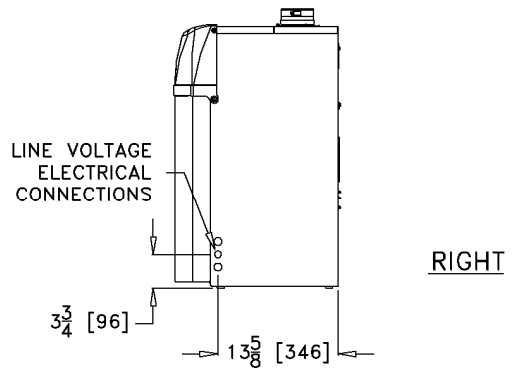
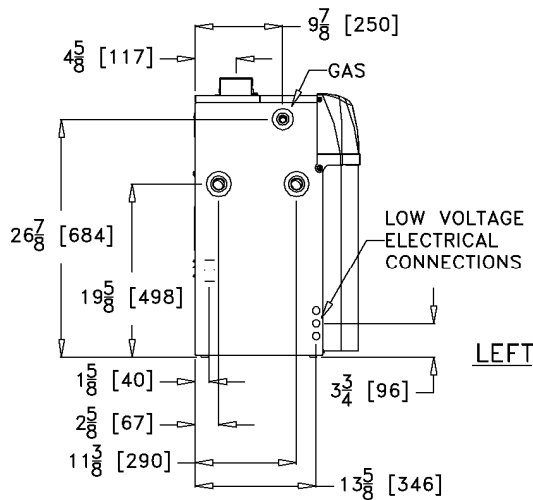
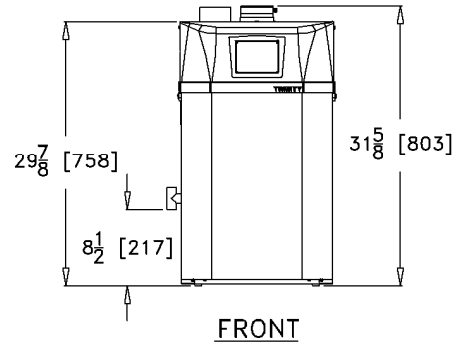
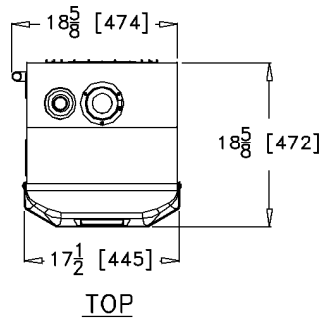

Recommended Clearances – in. [mm]

Top	Front	Left	Right	Back	Bottom
24 [610]	24 [610]	24 [610]	4 [102]	0	0



NY Thermal Inc.

65 Drury Cove Road Saint John, NB E2H 2Z8 Canada

Technical Service: 1-800-688-2575 Fax: 1-506-432-1135 Web: [http:// www.nythermal.com](http://www.nythermal.com)

NY Thermal Inc. reserves the right to change these specifications without notice



Trinity Lx200 High Efficiency Gas Condensing Boiler & Water Heater

Submittal Sheet

3 ELECTRICAL

Simplified Wiring Diagrams

Line Voltage Electrical:

- ▶ 120VAC / 60 Hz / 1 Phase / 12 Amp
- ▶ Barrier Strip for field wiring terminations
- ▶ 3 Pump outputs
 - Indirect Domestic Hot Water (Pump A)
 - Boiler (Pump B)
 - Central Heat (Pump C)

Note: Pumps are field supplied.

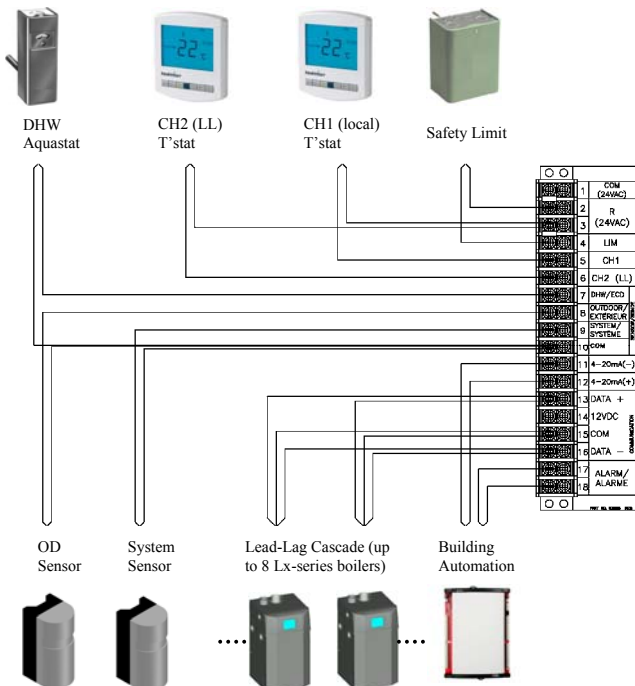
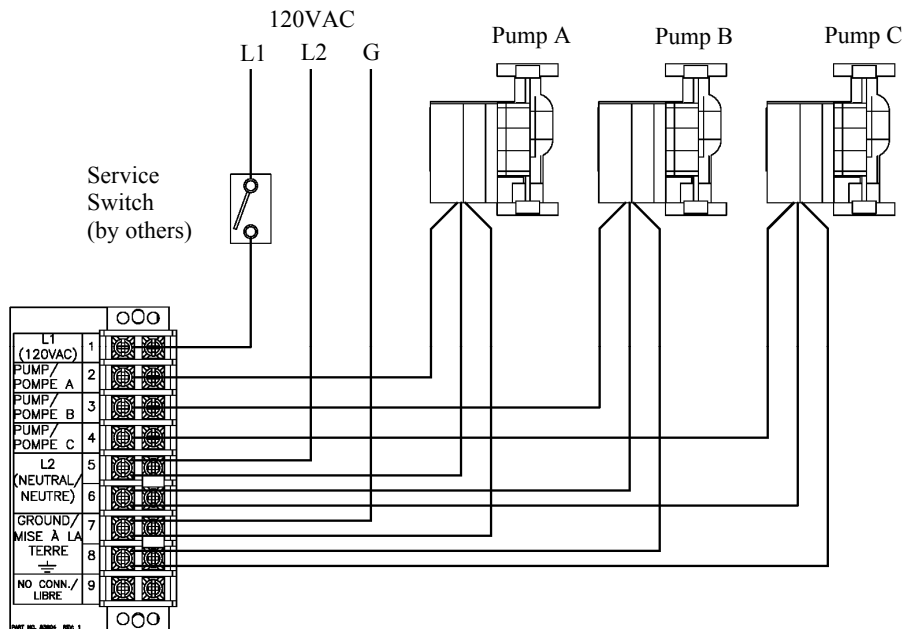

Low Voltage Electrical:

- ▶ Barrier Strip for field wiring terminations
- ▶ 120/24 VAC Transformer 40VA (factory supplied)
- ▶ Inputs
 - CH1 thermostat (by others)
 - CH2 thermostat (by others)
 - Indirect DHW aquastat (by others)
 - External Limit (by others)
 - Outdoor sensor (factory supplied)
 - System sensor (factory supplied)
 - 4-20mA external modulating control (by others)
- ▶ Outputs
 - Remote Touchscreen display (optional)
 - Alarm dry contact (24VAC 0.63A max.)
- ▶ EIA-485 Modbus communications for Lead-Lag



NY Thermal Inc.

65 Drury Cove Road Saint John, NB E2H 2Z8 Canada

Technical Service: 1-800-688-2575 Fax: 1-506-432-1135 Web: [http:// www.nythermal.com](http://www.nythermal.com)

NY Thermal Inc. reserves the right to change these specifications without notice