



# NY Thermal Inc.

## WF-200 Wood Fired Boiler

Date: 3-11-08

**Important:** read these instructions before operating or installing this boiler

### 1.0 Chimney Inspection

The boiler should be hooked up with a chimney of the following types:

- A) A factory built chimney, conforming to the required ULC S 629 Standard for 650°C Factory-built Chimneys. These are designed for wood fuel. They are typically called “all fuel” chimneys. The appropriate clearance of these chimneys from combustible materials is specified in the manufacturers installation instructions and also the listing label of the chimney selection. This is extremely important because of the possibility of chimney fires and the corrosiveness of creosote, such chimneys are built to withstand more severe conditions than standard types.
- B) Masonry and concrete chimneys, which are built in conformance with provincial regulations or in the absence of such regulations, are required to conform to the National Building Code. When hooking boiler to an existing chimney, that chimney must be one of the above and it should be inspected toughly before firing the equipment.

**NOTE: U.S. MARKET- TYPE B CHIMNEY IS THE ONLY ACCEPTABLE CHOICE (MASONARY)**

### Foundation

The boiler should never be installed on a combustible floor or base. Foundations shall be installed with the following minimum dimensions:

- (A) 4” Thick.
- (B) Extended 6” beyond the boiler in the sides and back.
- (C) Extend 18” in front.

### Placement of the Boiler and Combustible Material

Installation- Place boiler on non-combustible floor observe following minimum clearances to combustible material:

- Front 48”
- Right side and top 6”
- Coil side 24” (with coil)
- Coil side 6” (no coil installed)
- Flue pipe 18”
- Rear 24”
- Space above boiler not to be used for storage.

Connect only to approved (Class A) factory built chimney or tile lined masonry flue.

### Attention:

Clearance to a woodpile is 10’ (feet) in all directions.

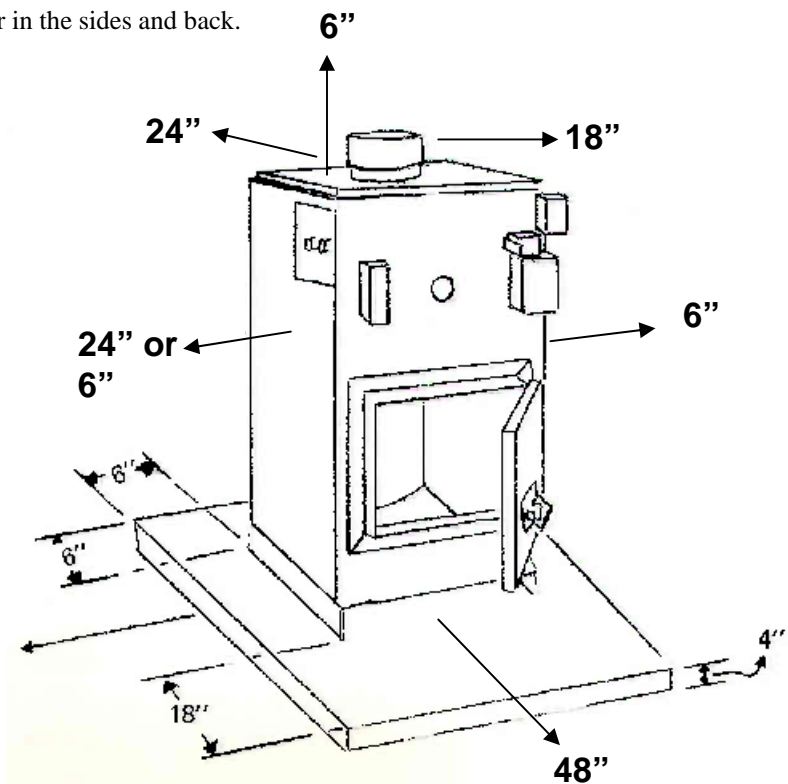

## 2.0 Ventilation & Combustion Air

The boiler should be provided with adequate fresh air for combustion when the boiler is installed, grilles should be placed near the ceiling and the floor to provide ventilation as well as air combustion. One square inch minimum free area per 1000 B.T.U. per hour input or 135 square inches for each gallon per hour required in each grille. Outdoor connections should be screened and provided with louvers. Refer to CSA Standard B365-19980. There should be at least 100 sq inches of free air space to allow for proper combustion air when installing a WF200.

## 3.0 Maintenance

1. Lubricate Circular motor and Bearing Assembly two times yearly. Use medium wt. oil.
2. A clean, properly maintained hot water system should not be drained unless there is a possibility of freezing, unless the boiler has accumulated a considerable amount of sludge or dirt on the water side, or unless draining is necessary to permit repairs. Very little sludge should accumulate in a boiler where little make-up water is added and where appropriate boiler water is maintained at proper strength.
3. Anti-freeze solutions, when used in a heating system, should be tested from year to year as recommended by the manufacturer of the anti-freeze that is used. This practice is not approved under the rules of the ASME Low pressure Heating Boiler Code. Check with local plumbing inspector for the proper "back flow prevent or".
4. Any water heater installed in, or connected to a boiler, should be back-washed periodically, using valves to reverse the direction of the flow through the heater. The purpose of this back washing is to reduce the amount of scale, which will accumulate at the outlet side of the heater. Continue the back washing until the water runs clear. The back washing may be done frequently and the maximum interval should be determined by trial.
5. When a sealer is used to eliminate system leaks and similar problems or if the sealer is used in conjunction with other compounds, the system should be completely flushed and drained after the sealer has performed their functions. A maximum interval of five days with the sealer in the system is recommended, sealers have a detrimental effect on boilers, pumps and relief valves and should be flushed out as quickly as possible. Note: using a sealer without flushing will void guarantee.

## 4.0 Venting Chimney Connector

Usually a few feet of flue pipe (single wall) are unused to connect the boiler to the chimney and in such cases, this section of the venting system is called for a chimney connector. A great number of fires associated with wood burning appliances are due to unsafe connector installations. The following requirements are designed to prevent two hazards: 1) ignition of the surroundings, principally by radiant heating, and 2) inadequate draft, which could result in serious smoke concentrations in the house. The minimum thickness of steel used for the flue pipe must conform to Table below.

Min Thickness of Metal used in Steel Flue pipes	
Diameter of Flue Pipe, In	Minimum Thickness, In
7-8	0.021

Each flue joint should be secured with at least 3 metal screws or equivalent. Outside mechanical support should be used if the connector is more that 6 feet long. The flue pipe should be accessible for inspection, cleaning and possible replacement.

If the flue pipe connects to an existing chimney, the pipe should penetrate through the inner surface of the masonry wall, but not beyond (not into the space itself.) The connection should be made physically secure such as through the use of high temperature cement.

A flue pipe serving a solid fuel appliance should:

- A. Be securely supported by metal or other non-combustible supports.
- B. Be as short and straight as possible.
- C. Not exceed a maximum 10-foot horizontal run.
- D. Be designed and constructed to allow for expansion.
- E. Be sloped upward toward the chimney at least ¼ inch per foot of horizontal run.
- F. Have a cross-section area no less than: 1) The area of the flue outlet of the appliance served by a flue pipe  
2) The combined area of the flue outlets of all the appliances served by a breeching.
- G. Enter the side of a chimney through an approved metal thimble or masonry flue ring.
- H. Not extend into the chimney flue.

- I. Have a tight connection with the chimney.
- J. Have installed at least three sheet metal screws to secure each length of flue pipe where they are joined and where it is attached to the wood boiler flue outlet.
- K. A flue servicing a solid fuel fired appliance should not pass through:
  - a. Attic or roof space, closet or similar concealed space
  - b. A floor, ceiling, wall or partition of combustion construction.

### 5.0 Recommended Piping Arrangement for Oil Add-ons

The recommended piping diagram shall require the installation of a hot water circulation loop that would dissipate at least 10% of the estimated rated heat of the solid fuel boiler in the event that circulation is reduced because off electrical power failure. This loop shall be such that it can only be made inoperative by a deliberate manual action.

Note: The design parameters for sizing this heat dissipation loop shall include: 1) minimum pipe size of 7/8"OD, 2) room ambient temperature of 18°C (65°F), and 3) a mean water temperature of 82°C (180°F).

A	Existing Oil Boiler
B	WF 200 Wood Boiler
C	Existing Heating Pump
D	Wood Boiler Pump
E	Isolation Valves
F	Expansion tank
G	Zone Valves (N.C.)
H	Dump Zone Valve (N.O.)
I	Existing Fill/Backflow Valve
J	Pressure Relief valve
K	L4006B Aquastat
L	L4081A Aquastat
M	Damper Motor
N	Existing Boiler Aquastat
O	Flow Check Valve
P	Swing Check Valve
Q	Water Supply
R	Existing system Return
S	Existing Boiler Supply
T	Supply to Zones
U	Alternate Return Location
V	Domestic Water Outlet

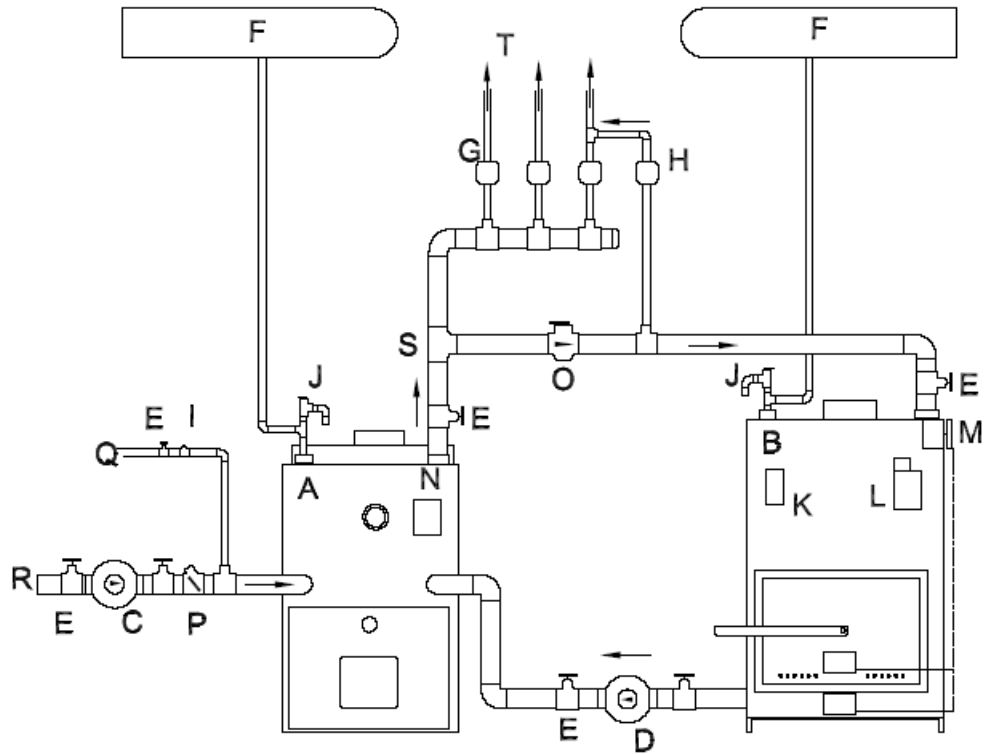

## 5.1 Suggested Wiring Diagram for Oil Add-ons

- Power both boilers from a single electrical circuit.
- Do not change the function of the controls on the oil boiler- it could void certification of the oil boiler.
- Enclosures of control devices are not to be used as junction boxes to extend supply circuits from one boiler to the other.
- Upon completion of the installation, adjustments of any controls, other than the room thermostats, should not be required when changing from one fuel to the other.

**Legend**

A- Dump zone valve  
 B- Transformer 20 VA 120-24V  
 C-M847A Damper motor  
 D- Wood Pump  
 E- System Pump  
 F- Oil burner

**120V, 60 HZ, 1PH less than 12 Amps**

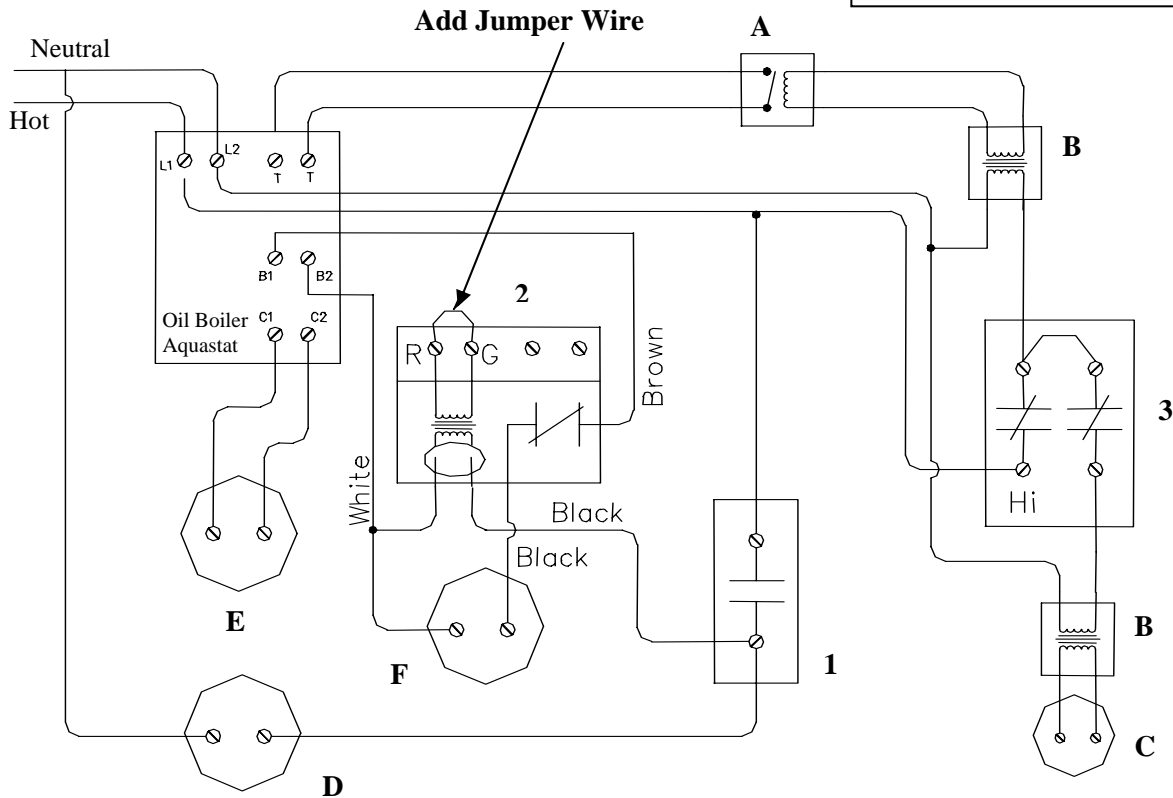

**May Be Wired Similarly with dual aquastat on the oil boiler**

Power supply- 120V, 60 HZ, 1PH less than 12 Amps. Wiring must be in accordance with CSA C22.1

No.	PN.	Description	Operation
1	13905	L4006B	SPST switch makes on temp. Rise to set point. Breaks on fall from set point minus differential. On rise R W contacts close energizing wood circulator, and at the same time power R8239A relay to de-energize N.C. Contacts in relay so the oil burner cannot operate
2	81313	R8285a OR 8A05A-101	Used as isolating relay. Will not allow oil burner to operate when wood circulator is running. Oil burner is powered from L8124A triple aqua stat through N.C. contacts in the R 8239A relay which contacts are open when wood circulator is powered through L4006B
3	13902 OR 81876	L4081A OR 11D05-1	2-SPST switches. Both break on rise, one acts as controller powering M847 damper motor on temperature fall. The other is a high limit switch wired in series with the controller. The high limit switch breaks power to both damper motor and N.O. damp zone valve. End switch of N.O. valve is connected to TT of L8124A triple aquastat to bring oil circulator on when temperature in wood boiler exceeds high limit setting of L 4081A aquastat.

In the event that the low water cut-off is used, a tapping has been provided on the front of the Boiler (3/4"). We recommend use of O.E.M. 170 L.W.C.O. or approved equal.

## Suggested Control Settings

L8124A aqua stat oil boiler or equivalent, HI 200°, LOW 180°, Diff 10°; L4006B aqua stat wood boiler, HI 190°, Diff 10°; L4081A aqua stat wood boiler, 220°, Low 200°.

### 5.2 Control Sequence for Oil Add-on

1. **Standby (( T T Open, No Wood Fire ))**. Oil boiler operates as normal.
2. **Standby (( T T Open, Wood Fire ))**. When the temperature in wood boiler rises to the set point of the L4006B control, the wood circulator is energized (pumping wood boiler water into the existing oil boiler), and power is energized to the switching relay Pn. 81313. This will interrupt power to the burner through the “Normally closed” contacts in the relay.
3. **Domestic Coil ((T T Open))**. If there is a call for domestic hot water, the oil boiler will remain OFF unless the temperature drops below the L4006B setting.
4. **Call For Heat ((T T Closed Wood Fire))**. When there is a call for heat, the oil boiler operates normally. If the temperature of the wood boiler is higher than the setpoint of the L4006B, the burner will be prevented from operating (normally closed contacts of switching relay, Pn. 81313). The wood circulator is energized pumping the wood boiler water into the existing oil boiler and into the house.
5. **Call For Heat ((T T Closed, No Wood Fire))**. Oil boiler operates as normal.
6. In the event that the boiler overheats (220°F L4006A Aquastat) or a power failure, the power to the normally open zone valve “H” will be lost, and the valve will open and water will flow by gravity around the dump zone loop. If in an overheat condition, the end switch of the dump zone will energize the TT of the Aquastat to energize the circulator. (See Wiring Schematic)
7. The Dump zone should be the largest zone in the house.

**CAUTION** Add wood according to the temperature outside. Overfilling will make the dampers close for extended periods of time creating creosote in the chimney.

### 5.3 Recommended Piping Arrangement for Trinity Gas Add-on

A	Trinity Boiler
B	WF Boiler
C	Trinity Pump (Hi Head)
D	Wood Boiler Pump
E	Isolation Valves
F	Expansion tank
G	Zone Valves (N.C.)
H	Dump Zone Valve (N.O.)
I	Fill/Backflow Valve
J	Pressure Relief valve
K	L4006B Aquastat
L	L4081A Aquastat
M	Damper Motor
N	Secondary Pump
O	Flow Check Valve
P	Swing Check Valve
Q	Water Supply
R	Secondary System Return
S	Secondary System Supply
T	Supply to Zones
U	Return From Zones

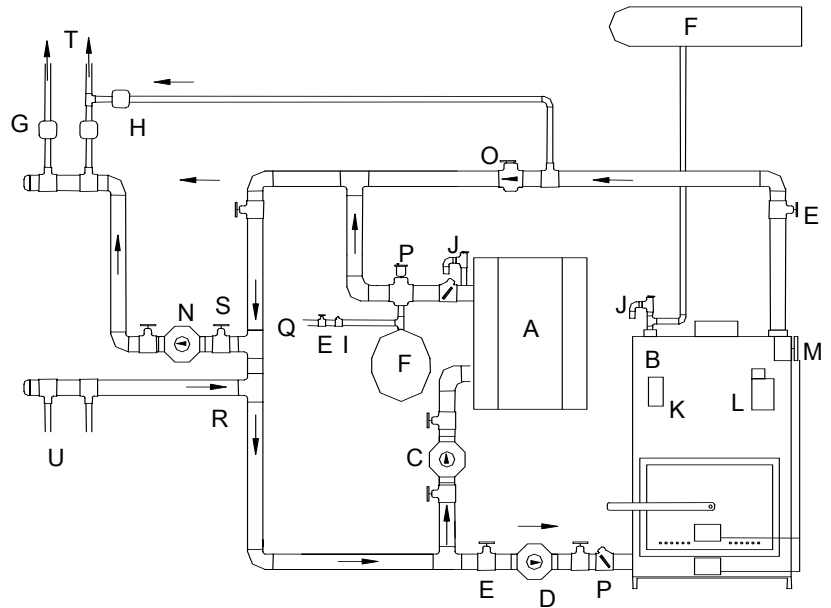

## 5.4 Suggested Wiring Diagram for Trinity Gas Boiler Add-ons

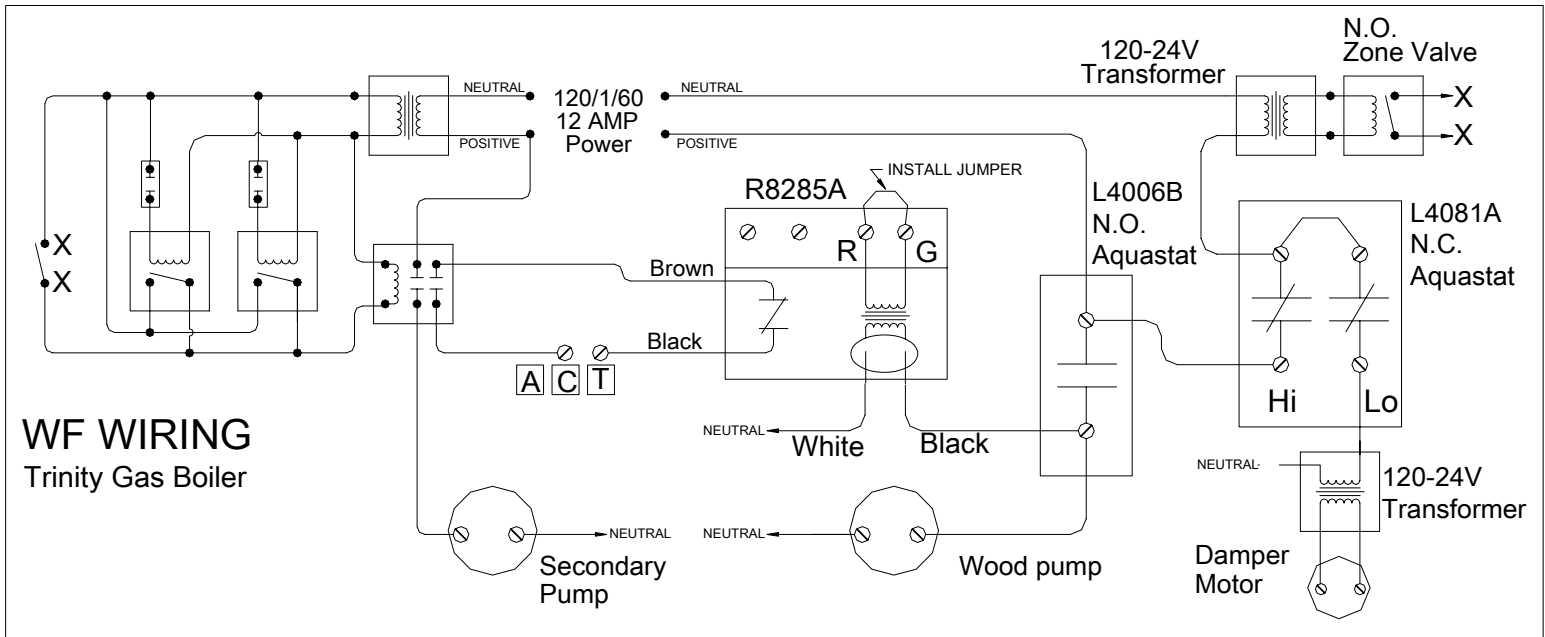

## 6.0 Recommended Piping Arrangement for Stand-alone

It is strongly recommended when installing a wood boiler as a single unit a re-circulating line be installed from the return to the supply of the boiler, as a wood burning unit does not recover cold water return as quickly as an oil burning unit.

<b>B</b>	WF Boiler
<b>C</b>	Heating Pump
<b>E</b>	Isolation Valves
<b>F</b>	Expansion tank
<b>G</b>	Zone Valves (N.C.)
<b>H</b>	Dump Zone Valve (N.O.)
<b>I</b>	Fill/Backflow Valve
<b>J</b>	Pressure Relief valve
<b>K</b>	L4006B Aquastat
<b>L</b>	L4081A Aquastat
<b>M</b>	Damper Motor
<b>Q</b>	Water Supply
<b>R</b>	Heating System Return
<b>S</b>	Heating System Supply
<b>T</b>	Supply to Zones

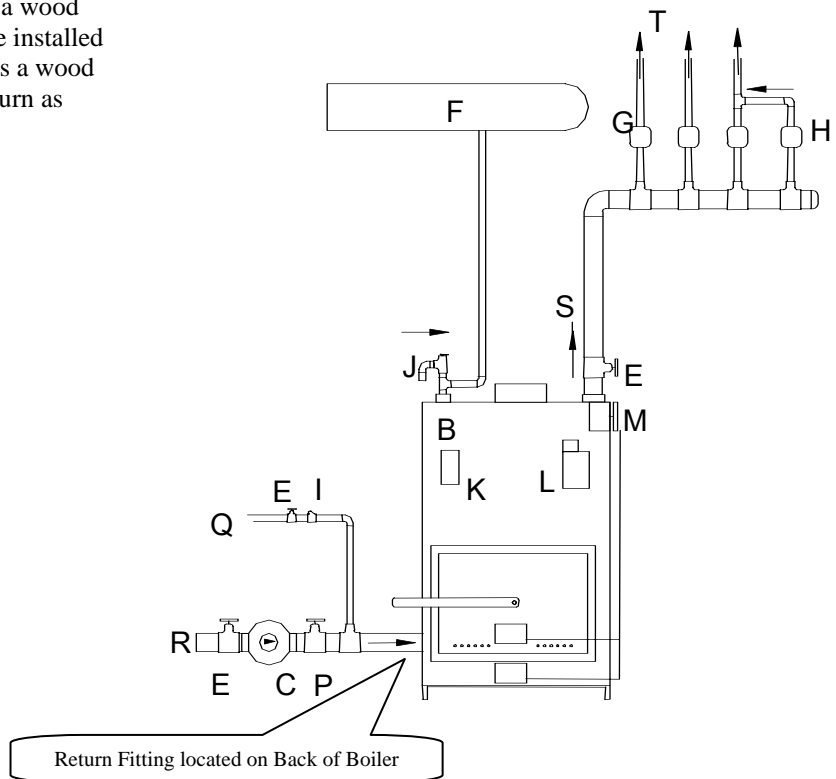



# Parts Diagram

- A Flush Jacket
- B Domestic Coil
- C Normally Open Zone Valve
- D Flue Reducer
- E Flue
- F Relief Valve Tapping
- G Supply Tapping
- H Damper Motor M847
- I Transformer AT20
- J Aqua stat L4062A
- K Pressure & Temperature Gauge
- L Aqua stat L4006 B
- M Relay R8239A
- N Transformer AT20
- O Damper Chain
- P Damper Door
- Q Fire Door
- R Combustion Area
- S Base
- T Return Tapping
- U Low water cut off

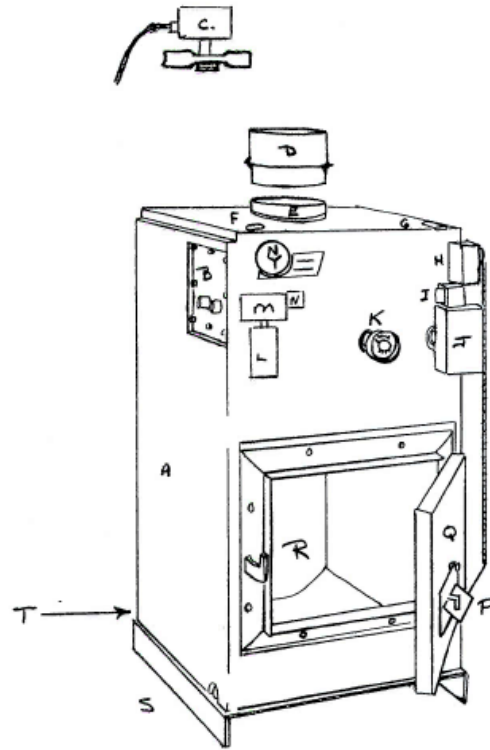

Tapping provided for  
 3/4" Low water cut-off  
 Model OEM 170 Safeguard  
 Or Approved Equal

# Dimensions

	WF 100	WF 200
<b>Dimension</b>		
A	42"	42"
B	37"	37"
C	13 1/2"	13 1/2"
D	15 3/4"	15 3/4"
E	6"	8"
F	7"	7"
G	7"	7"
H	22 1/2"	22 1/2"
I	23"	30"
<b>Chamber size (HxWxD)</b>	<b>18x16x19"</b>	
<b>Supply</b>	<b>1 1/4"</b>	<b>1 1/2"</b>
<b>Return</b>	<b>1 1/4"</b>	<b>1 1/2"</b>
<b>Relief Valve</b>	<b>3/4"</b>	<b>3/4"</b>
<b>Drain</b>	<b>1/2"</b>	<b>1/2"</b>
<b>Heating Surface (sq. Ft)</b>	<b>16</b>	<b>20</b>
<b>Weight (lbs)</b>	<b>540</b>	<b>625</b>
<b>Water volume (Imp. Gal)</b>	<b>33</b>	<b>43</b>

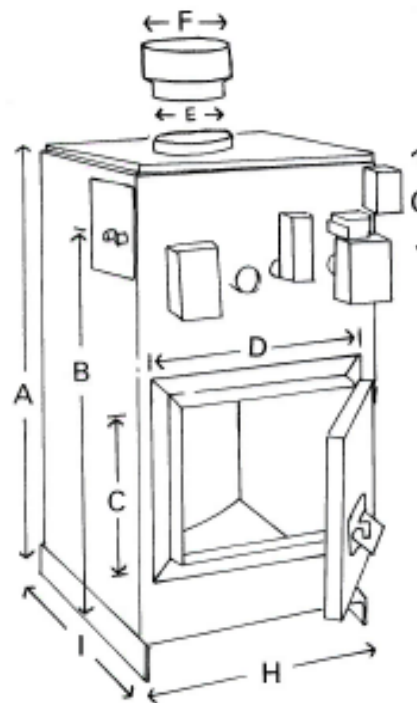

## Venting Hookup

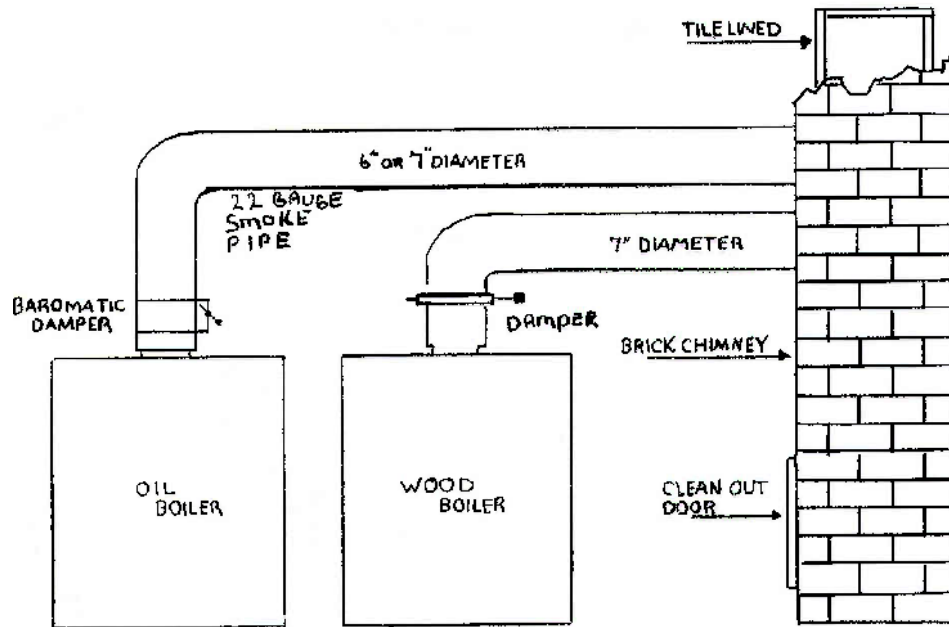

Note: U.S. Market:  
Wood boiler requires  
barometric damper  
installed

Important: Manual Draft Damper shown in this diagram only recommended in applications with very high draft conditions.

When Manual Dampers are installed they should provide no more than 80% closure when fully shut.

They must also be installed on a short piece of flue pipe that is easily removed to facilitate easy cleaning.

## Hot Water System

**Caution** Before putting water into a new boiler, make sure that the fireside is ready for operation. (Note: do not light a fire in an empty boiler) Once water is introduced operate the fireside to bring the boiler water up to temperature. This is necessary because raw water must be heated to at least 180°F immediately after it is introduced into the boiler, in order to drive off the dissolved gases, which might otherwise corrode the boiler.

The oil and grease, which accumulate in a new hot water boiler, can be washed out in the following manner:

- (a) Add caustic soda or presidium phosphate to the boiler water at the rate of 1 lb of either chemical per 50 gallons of total water in the system. Caution: Use care when handling these chemicals, the caustic soda is extremely corrosive to the skin and clothing. **DO NOT PERMIT EITHER THE DRY MATERIAL OR THE CONCENTRATED SOLUTION TO COME INTO CONTACT WITH SKIN OR CLOTHING.**
- (b) Fill the entire system with water.
- (c) Start the firing equipment.
- (d) Circulate the water through the entire system.
- (e) Vent the system including the radiation.
- (f) Allow boiler water to reach operating temperature if possible.
- (g) Continue to circulate the water for a few hours.
- (h) Stop the firing equipment.
- (i) Drain the system in a manner and to a location that hot water can be discharged with safety.
- (j) Wash the water side of the boiler thoroughly using a hose with sufficient pressure.
- (k) Refill the system with fresh water.
- (l) Bring water temperature up to at least 180°F immediately.
- (m) Tighten plugs while boiler is hot.
- (n) The boiler is now ready to put into service or on stand-by.

## How Much Water to Run in System

For Hot Water Heating, beginning with the lowest radiator, open vent and allow air to escape, closing vent when water begins to flow from it. Repeat this on all other radiators, continuing to second and then higher floors. (Radiators equipped with automatic air vent valves do not require venting by hand except to speed up initial filling of system.)

On open type system, after venting air from all radiators, the system should be filtered until water runs from the overflow connection on the expansion tank. On new heating systems remove rim and glass from altitude gauge and set stationary hand so that it indicates the same altitude as movable hand. Any recession of moveable hand below this reading thereafter indicates loss of water from the system due to leakage or evaporation. If this occurs refill system until movable and stationary hands again coincide.

All closed type systems should be provided with an air cushion tank and relief valve. Water should be fed to the system by means of an automatic fill valve available for that purpose. The relief valve should be opened occasionally to make sure it is operative. The relief valve should open before pressure indicated on the combination gauge exceeds thirty pounds. If this pressure is exceeded before relief valve opens, drain water from system until pressure is reduced below thirty pounds and have repaired or replaced immediately.

A waterlogged air cushion tank is indicated by rapid increase in pressure with only a slight increase in temperature, or frequent escape of water from relief valve.

Check Safety Relief Valve on Boiler Monthly- Test the safety valve by momentarily pulling lever to observe free escape of water.

**Please check with all local codes and ordinance before installing.**

## Caution

### Do not fire with wood until operating manuals and instructions are fully understood and:

- (1) Install and wire boiler only as described in manual.
- (2) Burn wood only- never use gas, oil or other liquids in fire
- (3) Never use rubber tires or creosote railway ties
- (4) Not suitable for Stoker firing
- (5) Do not load wood above the water baffle
- (6) Remove ash when height reaches 4" or less. Remove only when fire is completely out by using a shovel and placing ash in a metal container
- (7) Do not adjust draft higher than 0.5" in W.C.
- (8) Dry wood is recommended for safety and efficiency. Green or wet wood gives less heat and more smoke.
- (9) Damper should be opened for 6 seconds before opening fire door.
- (10) Always open door slowly, this will cut down the possibility of creating a suction and drawing smoke from combustion chamber
- (11) For safety keep fire door tightly closed.
- (12) Stored wood should not obstruct access to the boiler in any way
- (13) Stored wood should be piled in a way, which allows air to flow freely through it and not be piled at distance less than the distance shown on page (2) of this manual under the heading "Placement of Boiler and Combustible Material. These recommended clearances are especially important when changing or removing ash from boiler.
- (14) Insure that all seals on boiler are air tight to prevent over heating of boiler when combustion air damper is shut.

**Creosote** can be the result of incomplete combustion. When combustion is not complete or when the wood doesn't burn completely, unburned gases are given off. These unburned gases will be drawn through the boiler into the smoke pipe and exhausted through the chimney. When these gases cool down, creosote results. The colder they get the harder the creosote forms. The harder it forms the harder it is to remove. Creosote is still combustible and it will burn uncontrollably if ignited.

Creosote buildup can be avoided or kept to a minimum by:

1. Burning only seasoned dry wood.
2. Maintaining hot fires.
3. Using inside chimneys.

## Chimney Fires Or Runaway Fires

- Close all sources of air to the fire (including the draft regulator).
- Evacuate the house and call the fire department.
- Wet down combustible materials adjacent to the chimney.
- Do not take down flue pipe until fire is completely out.
- Do not use the chimney again until it has been inspected and repaired, if necessary.

By following these basic steps you will bring the fire under control. The time it takes to bring it under control depends upon the amount of fuel in the boiler and the rate at which it is burning at the time it is detected.

## Smoke Pipe Inspection

- The smoke pipe should be inspected on a regular basis during the heating season.
- Whenever possible the smoke pipe should be dismantled and cleaned out.
- The smoke pipe should be carefully examined for defects such as corrosion, seams coming apart, etc.
- If any defects are noticed the pipe should be replaced.
- 22-gauge galvanized stovepipe is recommended.