

# Trinity Lx

Model Numbers: Lx150-400

Version Date: 2010-01-01



## APPENDIX B - BOILER APPLICATIONS: PLUMBING AND WIRING INSTRUCTIONS

Optional Configuration: Refer to "Appendix C – Water Heater Applications"



### TABLE OF CONTENTS

1.0	INTRODUCTION .....	2
2.0	BOILER AND HEATING SYSTEMS PIPING.....	3
	Boiler System Preparation.....	3
	Boiler Water .....	3
	Near Boiler Plumbing.....	4
	Boiler System Plumbing.....	5
	Stand Alone Boiler Applications.....	7
	Multiple Boiler Applications.....	10
3.0	FIELD WIRING .....	13
	Line Voltage Connections.....	13
	Low Voltage Connections.....	15

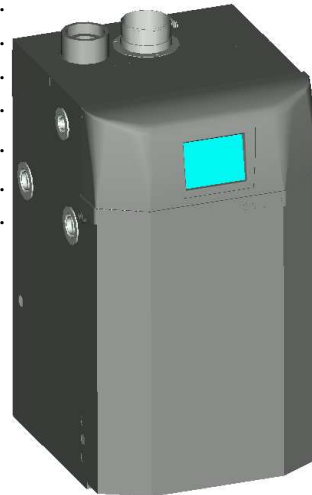

### HAZARD SYMBOLS AND DEFINITIONS



Danger Sign: Indicates a hazardous situation which, if not avoided, will result in serious injury or death.



Warning Sign: Indicates a hazardous situation which, if not avoided, could result in serious injury or death.



Caution Sign plus Safety Alert Symbol: Indicates a hazardous situation which, if not avoided, could result in minor or moderate injury.



Caution Sign without Safety Alert Symbol: Indicates a hazardous situation which, if not avoided, could result in property damage.

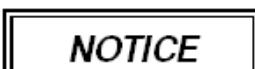

Notice Sign: Indicates a hazardous situation which, if not avoided, could result in property damage.



This Boiler must be installed by a licensed and trained Heating Technician or the **Warranty is Void**. Failure to properly install this unit may result in property damage, serious injury to occupants, or possibly death.

1.0 INTRODUCTION



**Boiler Applications** – These instructions apply to the plumbing and wiring for Trinity Lx150-400 units operating as boilers and covers instructions that are specific to boiler applications. When units Lx200 and Lx400 are installed and operated as a water heater, refer to "Appendix C - Water Heater Applications: Plumbing & Wiring Instructions". See Table 1-1 for a list of Application Manuals.

**Terminology** – The following terms in the instruction manuals are used to differentiate between which instructions are common-to-both and which are appliance-specific. The term "**APPLIANCE**" applies to both kinds of applications (boiler and water heater) and is used when conveying instructions which are common-to-both. The term "**BOILER**" or "**WATER HEATER**" is used when conveying instructions which are appliance-specific or specific to one or the other, but not both.

**Table 1-1 Instruction Manuals**

Appliance	Model No.	Installation and Operation Instructions (Common-to-Both)	Application Manuals (Appliance-Specific)
Boiler	Lx150-400	Trinity Lx Series	Appendix B Boiler Applications
Water Heater	Lx200 & 400	Trinity Lx Series	Appendix C Water Heating Applications

**General Installation Requirements**

The installation of your NTI Trinity gas boiler must conform to the requirements of this manual, your local authority, and the National Fuel Gas Code ANSI Z223.1 and or CAN/CGA B149 Installation Codes. Where required by the Authority, the installation must conform to the standard for “Controls and Safety Devices for Automatically Fired Boilers ANSI/ASME CSD-1.

This document pertains to the correct installation and operation of NTI Trinity boiler models Lx150, Lx150E, Lx200 and Lx400. The instructions detailed in this document supersede any and all previous instructions provided by NTI, written or otherwise. Each unit is provided with the following:

- 1) Installation and Operation Instructions for Trinity Lx Series,
- 2) Appendix A - Control and Touchscreen Display Instructions for Trinity Lx Series,
- 3) Appendix B - Boiler Applications: Plumbing and Wiring Instructions,
- 4) Appendix C - Water Heater Applications: Plumbing and Wiring Instructions, and
- 5) Natural to LP Conversion Kit \*

\* The conversion kit is required to convert the Appliance so it will safely operate with Propane Gas.



Read and understand this entire document prior to proceeding with the installation of the Trinity Lx boiler. Failure to follow the instructions outlined in this document will result in property damage, serious injury or death.



Failure to have the boiler properly serviced and inspected on a regular basis may result in property damage, serious injury or death.

**User Responsibilities**

This appliance may only be installed and serviced by a qualified boiler installer/service technician. For normal residential applications this boiler must be serviced / inspected annually, by a qualified boiler technician. Other applications (e.g. commercial or other more strenuous conditions) may require more frequent service/inspection. As the User/owner of this equipment, you are responsible for ensuring the maintenance is performed at the required intervals.

## 2.0 BOILER AND HEATING SYSTEMS PIPING

The heat exchanger of the Trinity boiler is designed to attain the highest level of heat transfer in a compact design. To accomplish this, the heating water flows through a series of fin shaped tubes, designed to maximize the heat transfer area. To maintain the efficient and reliable operation of the heat exchanger, and to avoid heat exchanger failure, it is critical to ensure the rules and guidelines in this section are followed.



### WARNING

Failure to follow the instructions provided in this section will void the NTI warranty and may result in property damage, fire, serious injury or death.

### Boiler System Preparation

Prior to connecting plumbing to the boiler, flush the entire system to ensure it is free of sediment, flux, solder, scale, debris or other impurities that may be harmful to the system and boiler. During the assembly of the heating system, it is important to keep the inside of the piping free of any debris including construction and copper dust, sand and dirt.

For retrofits, all system piping including radiators, must be cleansed of all build-up including sludge and scale. All systems, old and new, must be cleansed to remove flux, grease and carbon residue. NTI recommends cleansing the boiler system with “Ferrox F3 Cleaner”. For retrofit applications with heavy limescale and sludge deposits, a heavier duty cleaner may be required; NTI recommends the use of “Ferrox DS-40 System Cleaner”. For information on performing the cleansing, follow the instructions included with the Ferrox DS-40 System Cleaner. See Table 2-1 for list of recommended boiler cleansing products.



### CAUTION

Failure to rid the heating system of the contaminants listed above will void your NTI warranty and may result in premature heat exchanger failure and property damage.

**Table 2-1 Boiler System Cleansers and Corrosion Inhibitors**

Application	Ferrox Product	NTI Part #	Description
Boiler Water Treatment	F1 Protector	83448	Corrosion inhibitor.
Cleanser for new and old systems	F3 Cleaner	83449	Removes flux, grease and carbon residue.
Cleanser for Retrofits	DS-40 System Cleaner	83450	Removes heavy limescale and sludge deposits.

### Boiler Water

**Pressure** - The Trinity boiler is intended solely for use in pressurized closed loop heating systems operating with a minimum pressure of 15 PSI at the boiler outlet. To obtain the minimum system design pressure, follow the piping diagrams illustrated in this section.

**Oxygen Elimination** - This boiler may only be installed in a pressurized closed-loop heating system, free of air (oxygen) and other impurities. To avoid the presence of oxygen, ensure all of the air is removed from the system during commissioning via strategically placed adequately sized air-removal devices, located throughout the heating system. See figures in this section detailing the location of the primary air-removal device required for the boiler. Immediately repair any leaks in the system plumbing to avoid the addition of make-up water; make-up water provides a source of oxygen and minerals that may lead to heat exchanger failure. Failure to follow these instructions will result in poor performance, unnecessary wear of system components and premature failure.

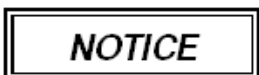

### NOTICE

The “Boiler Application” is not approved for operation in an “open system”, thus it cannot be used for direct potable water heating or process heating of any kind.

**Water Chemistry** – The installer of the Trinity Lx boiler must consider the condition of the water in the heating system. Ensure the condition of the boiler water falls within the following parameters:

- Water hardness – between 3 and 9 Grains/gal.
- PH – between 7.5 and 9.5.

**Treatment** - Boiler water that falls outside of the conditions listed above must be treated with a corrosion inhibitor. Each Trinity Lx boiler is provided with a bottle of “Ferrox F1” corrosion inhibitor, adequate to treat a 26.4 gallon (100 liter) heating system to a minimum required concentration of 0.5%. Systems with greater volume will require more inhibitor. For information on performing the treatment, follow the instructions included with the Ferrox F1 Protector. See Table 2-1 for a list of recommended boiler system cleansers and corrosion inhibitors.



To maintain protection, the level of corrosion inhibitor must be monitored periodically for the correct concentration.

**Anti-freeze** - For systems requiring freeze protection, use only inhibited propylene glycol, specially formulated for hydronic heating systems; use of other types of antifreeze may be harmful to the system and will void the warranty. Note: the use of glycol may reduce the usable output capacity of the boiler, thus requiring the unit to be “down-fired” by limiting the maximum operating capacity and/or the maximum water temperature. NTI recommends against exceeding 35% concentration of glycol.

### Near Boiler Plumbing

**Pressure Relief Valve** - A 30PSI Pressure Relief Valve is factory supplied with all boilers. Lx models dual certified as boilers or water heaters (Lx200/Lx400) include an additional 125PSI pressure relief valve. Since all Trinity Lx boilers, excluding Lx150’s sold in Canada (MAWP=30PSI), have a maximum operating pressure of 145PSI, a pressure relief valve with a higher discharge pressure rating (up to the MAWP of the boiler) may be used as long as the relieving capacity is in excess of the maximum input capacity of the boiler. This allows boiler installations to use either pressure relief valve (30PSI or 125PSI), while water heater installations are required to use the higher pressure relief valve (125PSI).

The pressure relief valve must be installed at the boiler outlet and in the vertical position, as shown in Figures 2-1(a) and (b), with the drain pipe outlet exiting the side of the pressure relief valve horizontally and elbowing down. If using a higher pressure relief valve, such as 125PSI, ensure the pressure gauge is sized to display the higher pressure valve (e.g. 160PSI pressure gauge).



If installed with the incorrect orientation (horizontally with drain pipe out the bottom) the relief valve may not function properly resulting in property damage or personal injury.



Ensure the discharge of the pressure relief is piped to a location where the steam or water will not cause property damage or serious injury.

**Pressure Gauge** – All models come with a factory supplied 30PSI Pressure Gauge. Models Lx200/Lx400, which are dual certified to be used as either a boiler or a water heater, have an additional factory supplied 160PSI pressure gauge. For boiler installations, either pressure gauge may be used. For water heater installations, the higher pressure gauge must be used along with the corresponding higher pressure relief valve. The pressure gauge must be installed at the appliance’s outlet prior to any circulators and in the vicinity of the pressure relief valve. See Figures 2-1(a) and (b).

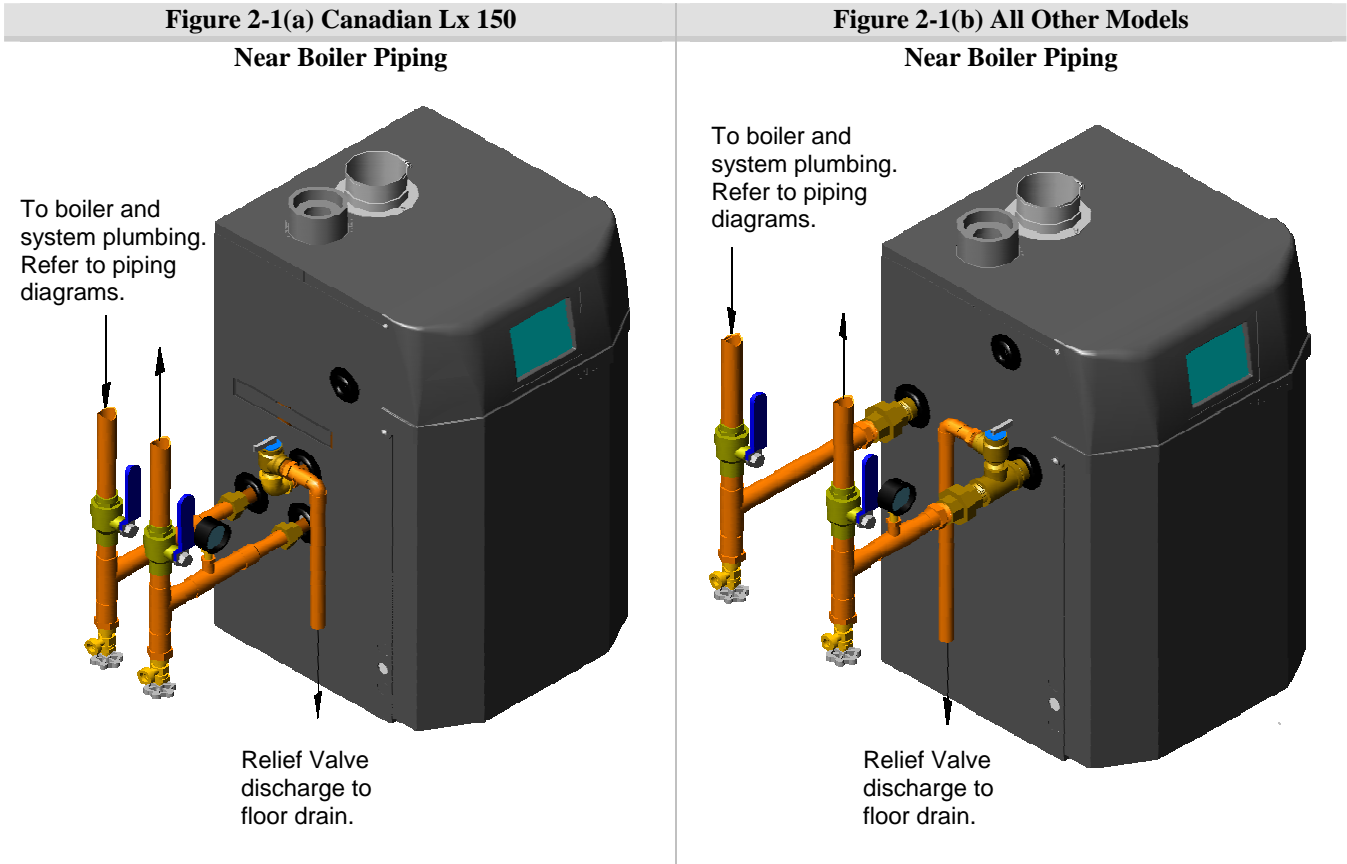

**Low Water Cutoff / Flow Switch** – The Trinity Lx boiler is not provided with a LWCO or Flow Switch, check with your local authorities for the requirements of these devices prior to installing the boiler. If a Flow Switch is installed it must be located in series with the boiler and in accordance with the instructions provided with the flow switch. NTI recommends a “McDonnell & Miller” flow switch installed in a 1” diameter line for all models except the Lx400, which requires an 1-1/2” diameter line.

**NOTICE** When external safety devices are used, such as a LWCO, Flow Switch, or a Temperature Limiting Switch, they must be wired as per the instructions provided in this manual. Refer to Section 3.0 for more information.

**Boiler System Plumbing**

The Trinity Lx boiler uses a low mass heat exchanger that requires a minimum rate of forced water circulation any time the burner is operating (See Table 2-3 for minimum flow rates). To ensure the minimum flow rate is attained, the boiler must be installed in a “Primary/Secondary” plumbing configuration utilizing “Closely Spaced Tees” to de-couple the Boiler-Primary loop from the System-Secondary loop(s). See the examples of Primary/Secondary Loop configurations in Figures 2-2 and 2-3.

**System Components** – As well as a Primary/Secondary Loop Configuration utilizing closely spaced tees a properly installed system will include the following major components identified in Table 2-2 as a minimum.

**Table 2-2 System Major Component Checklist**

Factory Supplied	Field Supplied Components
<input type="checkbox"/> Pressure Relief Valve (30PSI)	<input type="checkbox"/> Boiler Loop Circulator (Pump B in Figure 2-2 or Pump C in Figure 2-3)
<input type="checkbox"/> Pressure Gauge (30PSI)	<input type="checkbox"/> DHW Loop Circulator (Pump A in Figure 2-2 and Figure 2-3, for applications utilizing Indirect Fired Water Heater only)
	<input type="checkbox"/> Central Heat (CH) Loop Circulator(s) (CH Circulator - Pump C in Figure 2-2; Zone Circulators in Figure 2-3)
	<input type="checkbox"/> Central Air Removal Devices (i.e. Micro Bubbler or Air-Scoop)
	<input type="checkbox"/> Pressure Regulating “Fill Valve”
	<input type="checkbox"/> Backflow Preventor
	<input type="checkbox"/> Expansion Tank

**Circulating Pumps** – The Trinity Lx boiler is equipped with three 120VAC pump outputs:

1. PUMP A “DHW Pump” - operates during a Domestic Hot Water demand
2. PUMP B “Boiler Pump” - operates during any demand
3. PUMP C “CH Pump” - operates during a Central Heat demand (CH1 or CH2)

Ensure pumps are oriented as per the manufacturers’ instructions. Wiring of these circulators will depend on the system configuration chosen, see Figures 2-2 and 2-3. For further wiring details see Section 3.0.

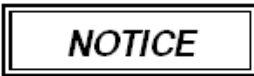

Circulators responsible for forcing the water flow rate through the boiler must be sized according to Table 2-3, see Figures 2-2 and 2-3 for details.



Failure to ensure the minimum water flow rate through the boiler when the burner is on will not only reduce the operating efficiency of the boiler, but may also cause premature failure, overheating and void the warranty. Failure to follow instructions may result in fire, property damage, serious injury or death.

**Table 2-3 Minimum Circulator and Pipe Sizes**

Model	Restriction Head Loss	Minimum Pipe Size	Min. Flow (GPM)	Max. Temp. Rise	Minimum Primary Loop Pump Size		
					B&G	Grundfos	Taco
150	7' at 6 GPM	1"	6	45°F	<b>PL-30</b>	UP 26-64	0011
150E	3' at 6 GPM	1"	6	45°F	<b>PL-30</b>	UP 26-64	0011
200	5' at 8 GPM	1-1/4"	8	45°F	<b>PL-36</b>	UP 26-99	0011
400	10' at 20 GPM	1-1/2"	16	45°F	<b>PL-36</b>	UP 26-99	0011 <sup>1</sup>

**Notes:**

1 - Recommend using a Taco 0013 for DHW indirect circulator on the Lx400 when installed as per Figure 2-3.

**Air Removal** – The boiler and system plumbing layout must be configured to promote the removal of air from the water. Air vents and bleeders must be strategically placed throughout the system to aid in purging the air from the system during commissioning of the boiler. The system must also employ the use of a strategically located air removal device, such as an air scoop or micro-bubbler, designed to remove the air from the water as it flows through the system.

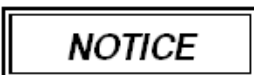

Follow the installation instructions included with the air removal device when placing it in the system; air removal devices generally work better when placed higher in the system. Always locate air removal devices in areas of the system that have a guaranteed positive pressure, e.g., in close proximity to the water fill and expansion tank.

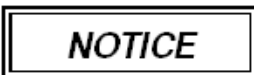

Trinity boilers are equipped with an automatic air removal device to aid in the purging of air from the boiler during the initial fill. This device is **NOT** intended, nor is it sufficient to remove the air from the system plumbing, even if the air makes it back to the boiler. A strategically located air removal device must be installed in the system.

**Expansion Tank** – The expansion tank must be sized in accordance with the water volume of the system as well as the firing rate of the appliance. It is important to locate the expansion tank, and make-up water fill, on the inlet side of any circulator in the system, as doing so will guarantee the lowest pressure in the system will be at least equal to the tank and make-up water pressure. See examples in Figures 2-2 and 2-3.



Ensure the expansion tank cannot become isolated from the boiler anytime the system is operating. Failure to follow these instructions may result in discharge of the Pressure Relief Valve may result in property damage or personal injury.

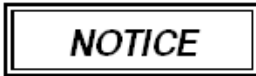

The installation of flow checks, motorized valves or other shutoff devices (other than for the purpose of servicing) are not permitted between the location of the “Closely Spaced Tees” and the expansion tank; see Figures 2-2 and 2-3.

**Indirect Fired Water Heater** – When installed as per Figure 2-3, the indirect fired water heater is in series with the boiler during a demand for DHW. Therefore when using this configuration it is important to use an Indirect Fired Water Heater that has minimal head loss. Indirect fired water heater head loss must not exceed those specified in Table 2-4, when installed as per Figure 2-3.

**Table 2-4 Maximum Indirect Fired Water Heater Head Loss (Boiler Side) at Minimum Flow**

Lx150	Lx150E	Lx200	Lx400
10’ at 6 GPM	14’ at 6 GPM	14’ at 8 GPM	9’ at 16 GPM

**Stand Alone Boiler Applications**

Single or stand alone boilers have the option of two heating inputs. On a central heat call, input CH1 is used as a lone input or as the high temperature input in a dual heating temperature system. CH1 is considered the “local” central heat call and has priority in a dual heating temperature system. The second central heat input (CH2) is used as a low temperature input in a dual heating temperature system. Figures 2-2 and 2-3 are examples of plumbing configurations for stand alone boilers using a single system circulator and multiple system circulators, respectively. Figure 2-3 also illustrates an optional second /low temperature heating zone.

**Figure 2-2: Single System Circulator Configuration** - Often used in applications zoned with “Zone Valves”. During a demand for central heat, the boiler energizes the System Circulator via the Central Heating (CH) pump output (PUMP C). The System Circulator must be sized to provide adequate circulation throughout the heating system. During a Domestic Hot Water (DHW) demand, the boiler de-energizes the System Circulator (PUMP C) and energizes the DHW Circulator (Pump A). With this configuration the Boiler Circulator is the only pump that causes flow through the boiler and it is powered during any demand via the boiler pump output (PUMP B). This circulator must be sized according to Table 2-3.

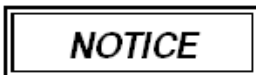

The piping configuration described above requires the Central Heating system and DHW system to be de-coupled from the “Primary Loop” via closely spaced tees (Figure 2-3).

**Figure 2-3: Multiple System Circulator Configuration** - Often used in applications with “Zone Circulators”. This configuration requires the installation of a check valve located at each circulator. During a central heating demand the boiler energizes the Central Heat Circulator via the Central Heat pump out (PUMP C). During a Domestic Hot Water (DHW) demand, the boiler de-energizes PUMP C and energizes the DHW Circulator (Pump A). Both Pump A and C, used in this configuration, are responsible for water flow through the boiler and must be sized according to Table 2-3. Pump output, PUMP B is not used in this configuration.

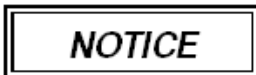

Figures 2-2 and 2-3 illustrate typical piping systems. These piping schematics do not illustrate all of the required concepts and components required to have a proper installation. Concepts not shown include: prevention of thermal-siphoning (heat traps), isolation valves, drain and purge valves, etc. It is the responsibility of the installing contractor and system designer to determine which system best meets the need of the installation and to consider all aspects of a proper system design. Contractor modifications to these instructions may be required, based upon existing piping and system design.



Figure 2-2 All Models

Stand Alone Boiler Plumbing Primary/Secondary Loop  
(Single System Circulator Configuration)

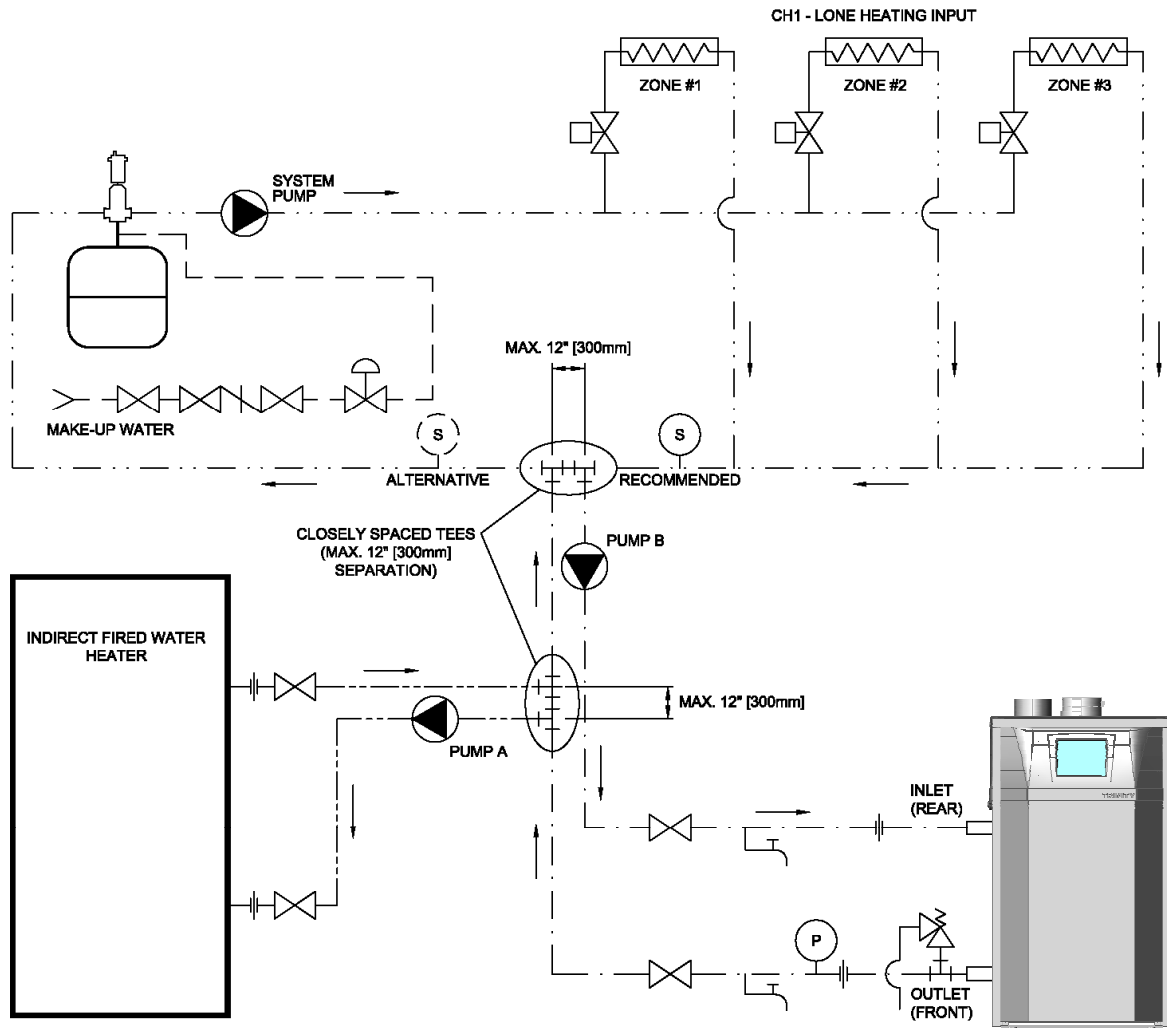

LEGEND					
SYMBOL	DESCRIPTION	SYMBOL	DESCRIPTION	SYMBOL	DESCRIPTION
---	MAKE-UP WATER		BACKFLOW PREVENTOR		AIR SEPARATOR
---	PRIMARY LOOP		PRESSURE RELIEF VALVE		PUMP
---	CENTRAL HEATING SECONDARY LOOP		PRESSURE REGULATING VALVE		UNION
---	DHW SECONDARY LOOP		DRAIN VALVE		TEE
	ISOLATION VALVE		AIR VENT		FLOW DIRECTION
	ZONE VALVE		EXPANSION TANK		SYSTEM SENSOR
	ZONE LOAD		PRESSURE GAUGE		

Figure 2-3 All Models

Stand Alone Boiler Plumbing Primary/Secondary Loop  
(Multiple System Circulator Configuration)

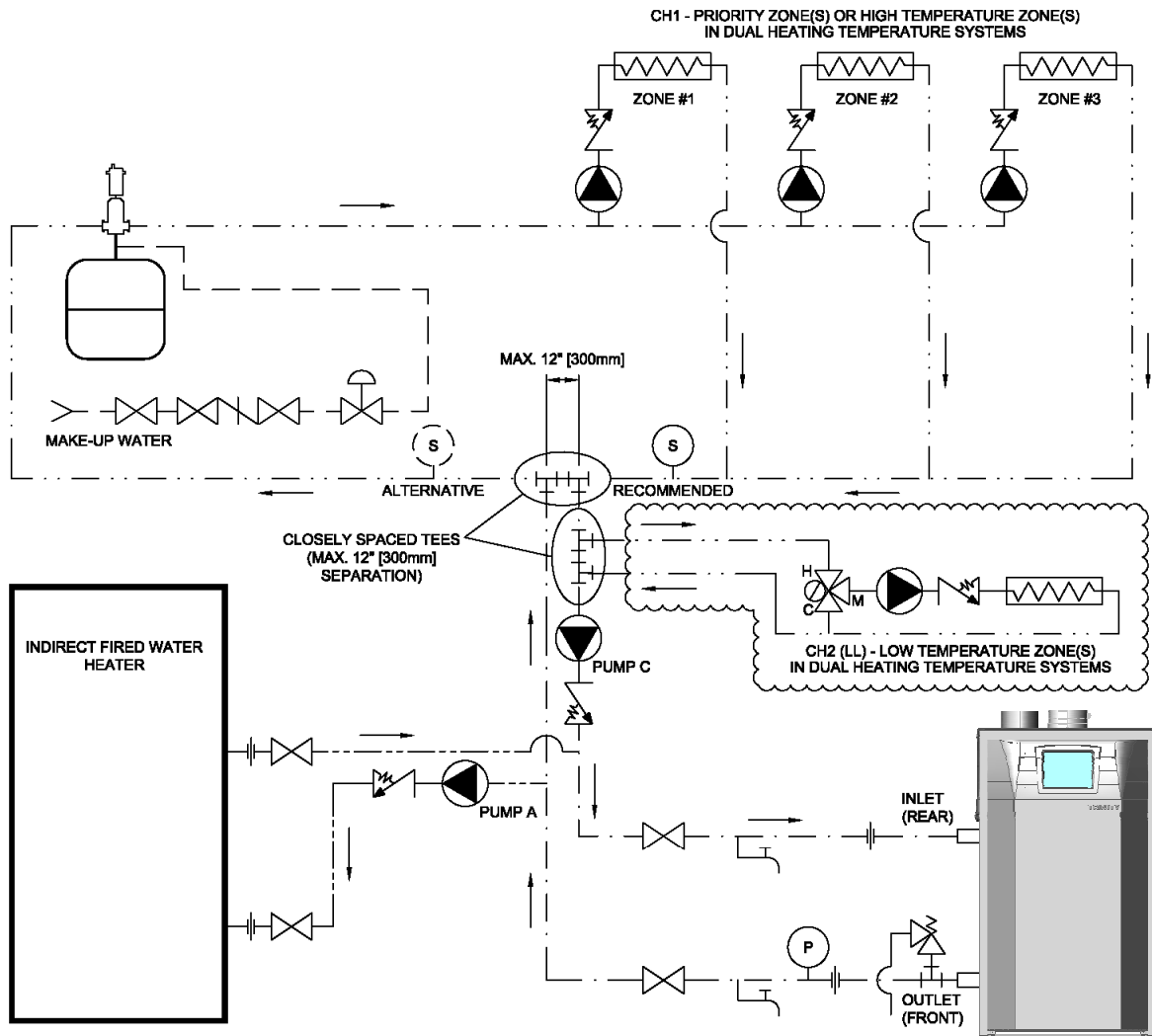

LEGEND					
SYMBOL	DESCRIPTION	SYMBOL	DESCRIPTION	SYMBOL	DESCRIPTION
---	MAKE-UP WATER		BACKFLOW PREVENTOR		AIR SEPARATOR
---	PRIMARY LOOP		PRESSURE RELIEF VALVE		PUMP
- . . -	CENTRAL HEATING SECONDARY LOOP		PRESSURE REGULATING VALVE		UNION
---	DHW SECONDARY LOOP		DRAIN VALVE		TEE
	ISOLATION VALVE		AIR VENT		FLOW DIRECTION
	ZONE VALVE		EXPANSION TANK		SPRING CHECK VALVE
	ZONE LOAD		PRESSURE GAUGE		SYSTEM SENSOR
	THERMOSTATIC MIXING VALVE		OPTIONAL		

**Multiple Boiler Applications**

The Lx controller has the internal capacity to stage or Lead-Lag up to 8 boilers configured in a cascade. This Lead-Lag capability allows a designated “Master” boiler to communicate with and effectively control each boiler in a multiple boiler system. This function is accomplished by “Daisy Chaining” a 3-wire cable between each of the boilers and enabling the Master parameter in the boiler of your choice. The boiler with the Master parameter enabled becomes the single point of contact for Central Heating and Outdoor Reset set-points as well as system control wiring such as the Thermostat demand and Outdoor and System Water Temperature. See section on Low Voltage Connections for wiring and control set-up details. Figures 2-4 and 2-5 are examples of multiple boiler plumbing configurations illustrating small and large DHW applications.



**Modbus Address** – Each boiler in a cascade arrangement (lead-lag) must have a unique modbus address between 1 and 8, inclusive. For detailed instructions on how to set the modbus address for each Lx controller, refer to "System Identification & Access" in Appendix A.

**Figure 2-4: Multiple Boiler Applications with Small DHW Requirements** – Used in applications where the DHW load can be satisfied by a single boiler. In this example, Boiler 1 provides DHW priority over Central Heating, while Boilers 2 and 3 provide Central Heating only; furthermore, the DHW demand to Boiler 1 comes directly from the Aquastat of the Indirect Fired Water Heater.

**Figure 2-5: Multiple Boiler Applications with Large DHW Requirements** – Used in applications where the DHW load is too large to be satisfied by a single boiler. In this example, Boilers 1 and 2 provide DHW priority over Central Heating, while Boiler 3 provides Central Heating only. In contrast to small DHW requirements, the Aquastat(s) of the Indirect Water Heater(s) is used to activate the main DHW pump and a relay is used to trigger individual contacts for the DHW inputs of Boilers 1 and 2. Refer to Figure 3-3 for relay wiring details.

During a Lead-Lag Central Heat demand [CH2 (LL)], the Master communicates the call to the applicable boiler(s); boilers attempting to satisfy the Central Heat demand will energize their local pump contacts B (Boiler) and C (Central Heat). Boilers not responsible for heating DHW use pump contact B for controlling their local Central Heat Pump (see Boilers 2 and 3 in Figure 2-4). Boilers responsible for heating DHW use pump contact C for controlling the local Central Heat Pump (see Boilers 1 and 2 in Figure 2-5). A boiler receiving a local DHW demand will turn off pump contact C for Central Heat and will activate pump contact A for DHW, thus providing DHW priority.

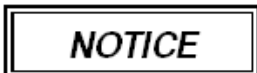

With the exception of the Main System circulator in Figures 2-4 and 2-5 and the Main DHW circulator in Figure 2-5, all circulators must be sized according to Table 2-3.

**System Circulator** - The installer can designate one of the boilers, preferably one not responsible for DHW heating, to control the operation of the System Circulator. Via the user interface, under “Pump Configuration” and “Central Heat Pump”, check the box labeled “Use for Lead Lag Master demand”. This forces the local pump output C to activate when the Master gets a Lead-Lag Central Heat demand [(CH2 (LL))]. Pump output C can then be used to power the System Circulator. Due to the large load of a typical system circulator, it is recommended that a 120VAC isolation relay be used instead of powering the system circulator directly from pump output C (i.e. pump output C is limited to 3 Amps or 1/6hp).

**Table 2-5 Minimum Pipe Sizes for Multiple Boiler Applications**

# of Units	Lx150/150E	Lx200	Lx400
	Pipe Size	Pipe Size	Pipe Size
1	1-1/4"	1-1/4"	1-1/2"
2	1-1/2"	2"	2-1/2"
3	2"	2"	3"
4	2"	2-1/2"	3"
5	2-1/2"	2-1/2"	4"
6	2-1/2"	3"	4"
7	2-1/2"	3"	5"
8	2-1/2"	3"	5"

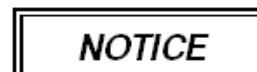

All boiler piping for **Multiple Boiler Applications** must be sized according to Table 2-5.

Figure 2-4 All Models  
Multiple Boiler Lead-Lag Plumbing Configuration  
(Small DHW Requirements)

LEGEND			
SYMBOL	DESCRIPTION	SYMBOL	DESCRIPTION
---	MAKE-UP WATER	⌘	BACKFLOW PREVENTOR
---	PRIMARY LOOP	⊙	PRESSURE RELIEF VALVE
---	CENTRAL HEATING SECONDARY LOOP	⊕	PRESSURE REGULATING VALVE
---	DHW SECONDARY LOOP	⌒	DRAIN VALVE
⌘	ISOLATION VALVE	↑	AIR VENT
⌘	ZONE VALVE	⊖	EXPANSION TANK
⌘	ZONE LOAD	⊕	PRESSURE GAUGE
⊕	SYSTEM PUMP	⊕	SYSTEM SENSOR

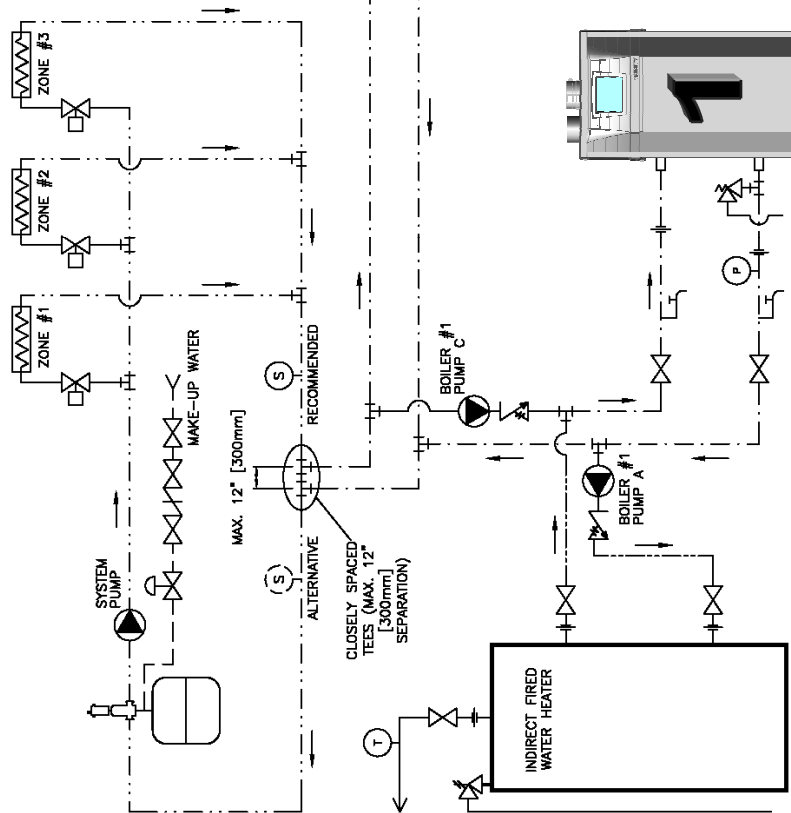
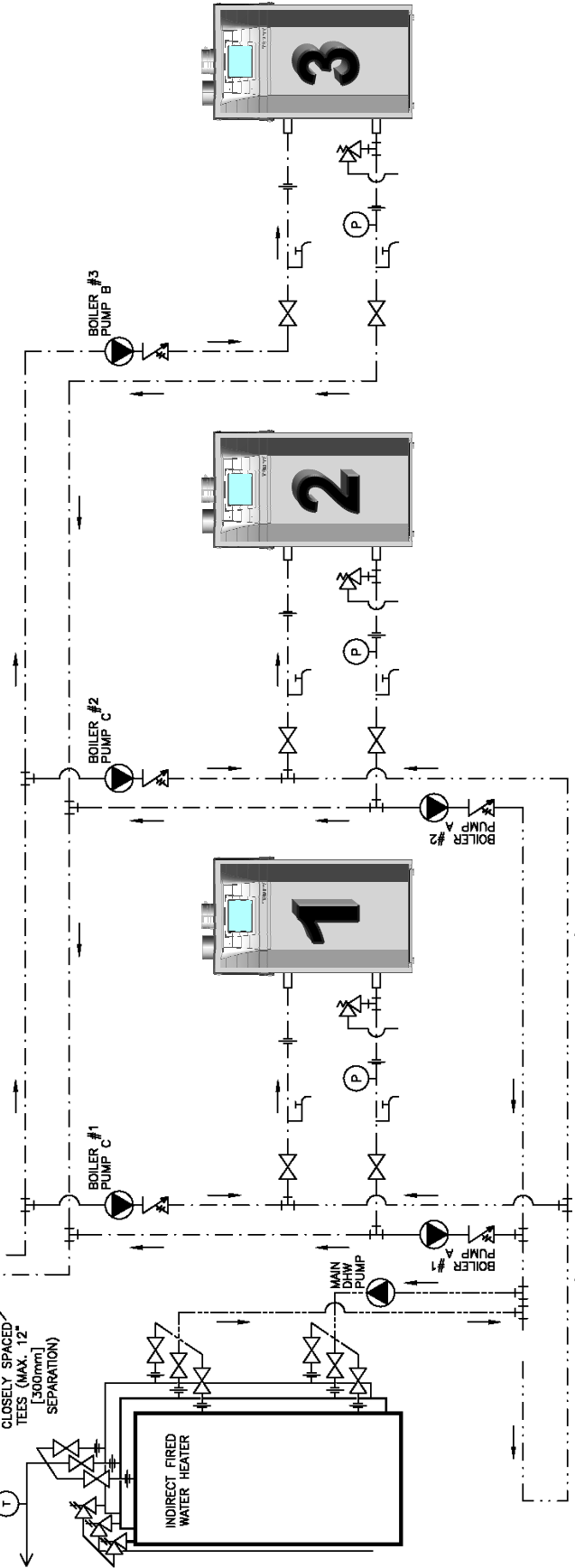
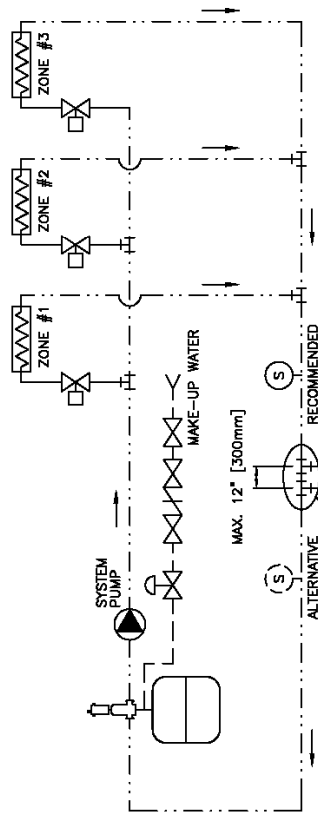

Figure 2-5 All Models  
Multiple Boiler Lead-Lag Plumbing Configuration  
(Large DHW Requirements)

LEGEND			
SYMBOL	DESCRIPTION	SYMBOL	DESCRIPTION
---	MAKE-UP WATER	⌘	BACKFLOW PREVENTOR
---	PRIMARY LOOP	⊙	PUMP
---	CENTRAL HEATING SECONDARY LOOP	↑	PRESSURE RELIEF VALVE
---	DHW SECONDARY LOOP	⌘	PRESSURE REGULATING VALVE
⌘	ISOLATION VALVE	⌘	DRAIN VALVE
⌘	ZONE VALVE	↑	AIR VENT
⌘	ZONE LOAD	⌘	EXPANSION TANK
⌘	ZONE LOAD	⊙	PRESSURE GAUGE
⌘	ZONE LOAD	⊙	SYSTEM SENSOR



### 3.0 FIELD WIRING

All wiring must be in accordance with the Canadian Electrical code, CSA C22.2, and any applicable local codes. Ensure that the wiring is in accordance with this manual. The boiler must be electrically grounded in accordance with the National Electrical Code ANSI/NFPA 70, or local codes, and/or the Canadian Electrical Code CSA C22.1.



**Avoid Shocks** - To Avoid Electrical Shock, turn off electrical power to the boiler prior to opening any electrical box within the unit. Ensure the power remains off while any wiring connections are being made. Failure to follow these instructions may result in component failure, serious injury or death.



**Field Wiring** - Wire grommets must be used to secure wiring and prevent chafing when passing wiring through the boiler cabinet. Failure to follow instructions may damage unit.

#### Line Voltage Connections

The Trinity Lx line voltage junction box is located in the lower right corner of the boiler cabinet on models Lx150-200 and can be accessed by removing the front door of the boiler, followed by the removal of the line voltage junction box cover. On Lx400 models, the line voltage junction box is located at the top of the boiler cabinet on the right hand side and can be accessed by removing the top front cover of the boiler. The boiler is provided with one hole and two knockouts for routing field wiring into the line voltage junction box. Line voltage field connections identified in Table 3-1 to be read in conjunction with Figure 3-1.

**Fuses (120VAC)** – The Trinity Lx is equipped with two 7 Amp fuses to protect 120VAC system components. The fuses are located on the front of slide-out control panel box.

- Fuse A: Protects the blower, spark generator and PUMP B output circuits.
- Fuse B: Protects PUMP A and C output circuits.



**Wire Protection** - When passing any wiring through the cabinet of the boiler, the installer must use wire grommets suitable for securing the wiring and preventing chafing. Failure to follow instructions may result in component failure, serious injury or death.



**Power Supply** - The Trinity Lx is designed to be powered using a single phase 120VAC power supply that is fused (or protected via a circuit breaker) to allow a maximum of 15 Amps. Failure to follow instructions may result in component failure, serious injury or death.



**Labeling** - Label all wires prior to disconnecting them when servicing controls. Wiring errors can cause improper and dangerous operation. Failure to follow instructions may result in property damage or personal injury.



**Continuity** - Before connecting the line voltage wiring, perform a continuity check between all wires and ground to make sure that there are no electrical leaks that could blow a fuse or damage electrical components. Also check the polarity of the line and neutral wires. Line must measure 120VAC to ground; neutral must measure zero. Failure to follow instructions may damage the unit.



**Max Load** - The circulator outputs, PUMP A through C, are each limited to operating a circulator with a maximum current load of 3 Amps or a maximum 1/6 hp motor. See Table 3-1.

Figure 3-1 All Models  
Line Voltage Field Wiring

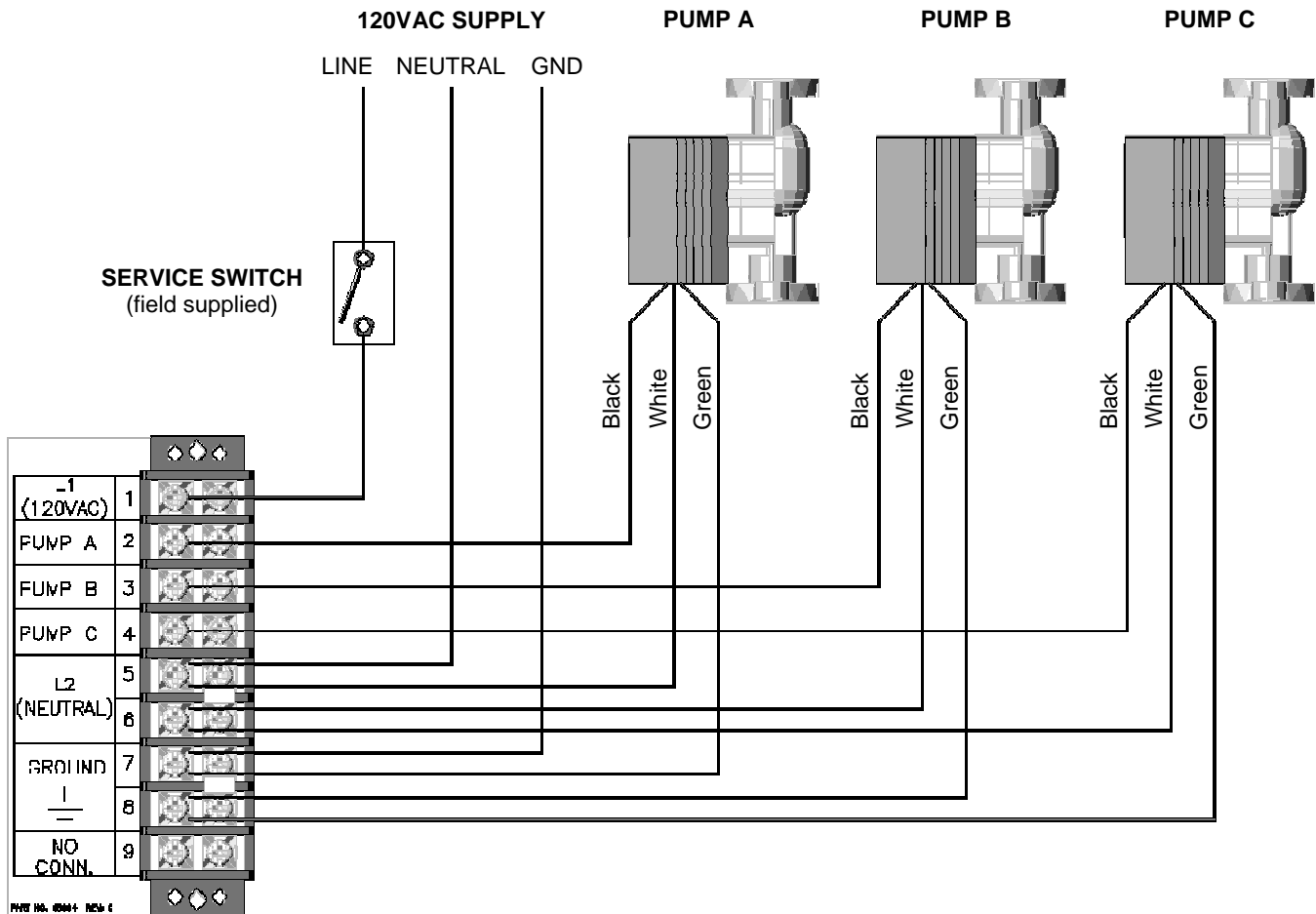

Table 3-1 Line Voltage Field Connections

Connection	Location	Description
L1 (120VAC)	1	Location for connecting line voltage of the power supply. Note; most installation codes require the installation of a service switch to break line voltage to the appliance.
PUMP A	2	120VAC output to the DHW circulator; powered during a demand for DHW.
PUMP B	3	120VAC output to the Boiler circulator; powered during all demands; DHW, local Central Heat (CH1) and Lead-Lag Central Heat [CH2 (LL)]. This output is not used for all plumbing configurations, see Section 2.0.
PUMP C	4	120VAC output to the Central Heating circulator; powered during a demand for local Central Heat (CH1) or Lead-Lag Central Heat [CH2 (LL)].
L2 (Neutral)	5	Location for connecting neutral of the power supply and all circulators.
	6	
Ground	7	Location for connecting earth ground and for grounding all of the circulators.
	8	
No Conn.	9	This terminal is used only for factory wiring, do not add or remove wires from this location.

**Low Voltage Connections**

The Trinity Lx low voltage junction box is located in the lower left corner of the boiler cabinet on Lx150-200 models and can be accessed by removing the front door of the boiler, followed by the removal of the low voltage junction box cover. On Lx400 models, the low voltage junction box is located at the top of the boiler cabinet on the left hand side and can be accessed by removing the top front cover of the boiler. The boiler is provided with one hole and two knockouts for routing field wiring into the low voltage junction box. Low voltage field connections identified in Table 3-2 are to be read in conjunction with Figure 3-2 for stand-alone boiler applications and Figures 3-3 and 3-4 for multiple boiler applications.

**Two Central Heat Inputs** - The Trinity Lx series has the capability of modulating to two separate central heat demand calls using connection terminals CH1 (formally "T") and CH2 (LL). CH1 is considered to be the "local" call; therefore, it has priority over CH2 (LL).

**Table 3-2 Low Voltage Field Connections**

Connection		Location	Description
COM (24VAC)		1	<b>24VAC Common</b> – Neutral for the 24VAC power supply from the boiler. COM can be used in conjunction with terminal R to provide a power source for a digital thermostat.
R (24VAC)		2	<b>24VAC Hot</b> - Power supply for inputs LIM, CH1, and CH2 (LL).
		3	
LIM		4	<b>External Limit</b> – Input requiring 24VAC from terminal R to permit the burner to operate. Comes factory equipped with a jumper to the R terminal. For installations requiring the use of an additional safety switch, such as a LWCO, Flow Switch, or auxiliary temperature limit, remove the factory installed jumper and install the normally open isolated contacts of the additional limit in its place.
CH1		5	<b>Local Central Heat Demand</b> – Input requiring 24VAC from terminal R to initiate a "local" CH call. Switch is made using an isolated end switch (dry contact) via thermostat, zone controller or other device. Typically used as the lone heat input or as the high temperature input in dual CH temperature systems.
CH2 (LL)		6	<b>Lead-Lag Central Heat Demand</b> – Input requiring 24VAC from terminal R to initiate a "lead-lag" CH call. Switch is made using an isolated end switch (dry contact) via thermostat, zone controller or other device. Typically used as a lead-lag input for cascaded boilers or as the low temperature input in dual CH temperature systems.
Sensor	DHW	7	<b>DHW Tank Demand</b> – Input requiring closure of terminals 7 and 10 to initiate a demand for DHW. Switch made via isolated end switch (dry contact) from a thermostat (aquastat) located in an Indirect Fired Water Heater.
	OD SENSOR	8	<b>Outdoor Temperature Sensor</b> – A wall mountable OD Sensor is included with each boiler. When connected to terminals 8 and 10, the control will indicate the outdoor temperature and adjust the boiler temperature set point during a Central Heat demand.
	SYSTEM	9	<b>System Water Temperature</b> – A strap-on System Sensor is included with each boiler. When connected to terminals 9 and 10, the control will indicate a Lead-Lag Temperature and adjust the boiler temperature set point during a Central Heat demand.
	SENSOR COM	10	<b>System Common</b> – Common port for field inputs DHW, OD Sensor and System Sensor.
4-20mA		11	<b>External Modulation Control</b> – Using a 4-20mA signal, an external control can be used to directly modulate the burner firing rate or adjust the active set point. This can be useful for applications using external staging controls or Building Automation Systems.
		12	
Communications	DATA +	13	<b>Remote Display</b> – Terminals 13 through 16 can be used to connect a second user interface remotely.
	12VDC	14	
	COM	15	<b>Lead-Lag</b> – Terminals 13, 15 and 16 can be "daisy-chained" to multiple boilers (up to 8 total) for the purpose of staging.
	DATA -	16	
ALARM		17	<b>Normally Open Alarm Contacts</b> – Contacts close during a lockout or other alarm condition. May be connected to a BMS, maximum capacity of 0.63Amps at 24VAC.
		18	

**Local Central Heat Input (CH1)** - Terminal CH1 (formally "T") is used for a lone heating input on a stand-alone boiler or as the high temperature input for a system with dual central heat temperatures. *Example:* If there is a call for central heat on CH1 and a second heat call on CH2 (LL), the boiler will respond to CH2 (LL) once the CH1 call is finished. See Figure 3-2 for low voltage field wiring schematic.

**Lead-Lag Central Heat Input [CH2 (LL)]** - Terminal CH2 (LL) is used in lead-lag applications as the central heat call for cascading boilers or as the low temperature input (i.e. in-floor radiant) for systems with dual central heat temperatures. *Example:* In a lead-lag configuration, only one boiler is designated (enabled) as the "Master". The "Master" knows which slave boiler(s) are temporarily "on leave" with a local call; consequently, it will send the lead-lag call to the next available boiler in the cascade. See Figure 3-4 for low voltage field wiring schematic.



**CH2 (LL) Input** - To use CH2 (LL) for staging or as a second central heat input, Master enable must be set to "Enabled". See "Lead Lag Master Configuration" in Appendix A.



**Modbus Address** - In a multiple boiler Lead Lag cascaded installation, each controller's Modbus Address must be set to a unique value between 1 and 8, inclusive. Refer to "System Identification & Access" in Appendix A.

**System Sensor [S10 (J10-7)]** - A factory supplied, field installed strap-on pipe sensor is included with each boiler and can be installed on the pipe of the system return (recommended) or system supply (alternative) to provide an indication of the actual system temperature. The System Sensor is the default Modulation Sensor for a CH2 (LL) demand and can be used as the Modulation Sensor for a CH1 demand as well.



**System Sensor** - Strap-on sensors typically register a lower than actual water temperature in the pipe. To offset this, the manufacturer recommends reducing the maximum CH set point by 10-15 degrees and insulating around the installed System Sensor. Failure to follow these instructions will result in higher than anticipated water temperatures, personal injury or system damage.

**Modulation Sensor** - The temperature sensor used for modulating the boiler firing rate; the controller attempts to make the temperature sensed at the "Modulation Sensor" equal to the programmed set point. See Table 3-3.



**Modulation Method** - If modulating to return temperature via the Inlet or System Sensor, lower the maximum CH set point by 20 degrees to prevent temperature overshoot and/or damage to the unit. Failure to follow these instructions will result in higher than anticipated operating temperatures possibly resulting in personal injury or system damage.

**Table 3-3 Modulation Sensor Settings**

Demand Call	Application	Factory Default	Alternative Sensor	LL Master Configuration
DHW demand	DHW	Outlet Sensor	Inlet Sensor	n/a
CH1 demand	Local	Outlet Sensor	Inlet or System	n/a
CH2 (LL) demand	Lead-Lag or Second Central Heat Input	System Sensor	Outlet Sensor	Enabled <sup>1</sup>

**Notes:**

<sup>1</sup> On multiple boiler applications using Lead-Lag [CH2 (LL) input], only the designated Master shall be "Master enabled".

**Warm Weather Shutdown (WWSD)** - When enabled, the control will prevent CH operation when the Outdoor Temperature (ODT) goes above the WWSD setpoint. [ODT > WWSD = WWSD ON]. CH operation is permitted once the Outdoor Temperature drops below the WWSD setpoint by 4°F [ODT ≤ (WWSD - 4°F) = WWSD OFF].



**Low Voltage Terminals** - Terminals 2 and 3 (R) have 24VAC potential from the internal transformer. Do not connect power from these terminals to any other terminal other than terminals 4, 5 and 6 [LIM, CH1, and CH2 (LL)]. Failure to follow these instructions may damage the unit.

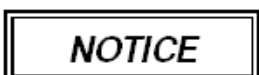

**Fuse (24VAC)** - The Trinity Lx is equipped with a "blade style" 2 Amp fuse to protect the internal transformer. The fuse is located within the slide-out control panel box.

**Figure 3-2 All Models**  
**Low Voltage Field Wiring**  
**(Stand Alone Boiler Configuration)**

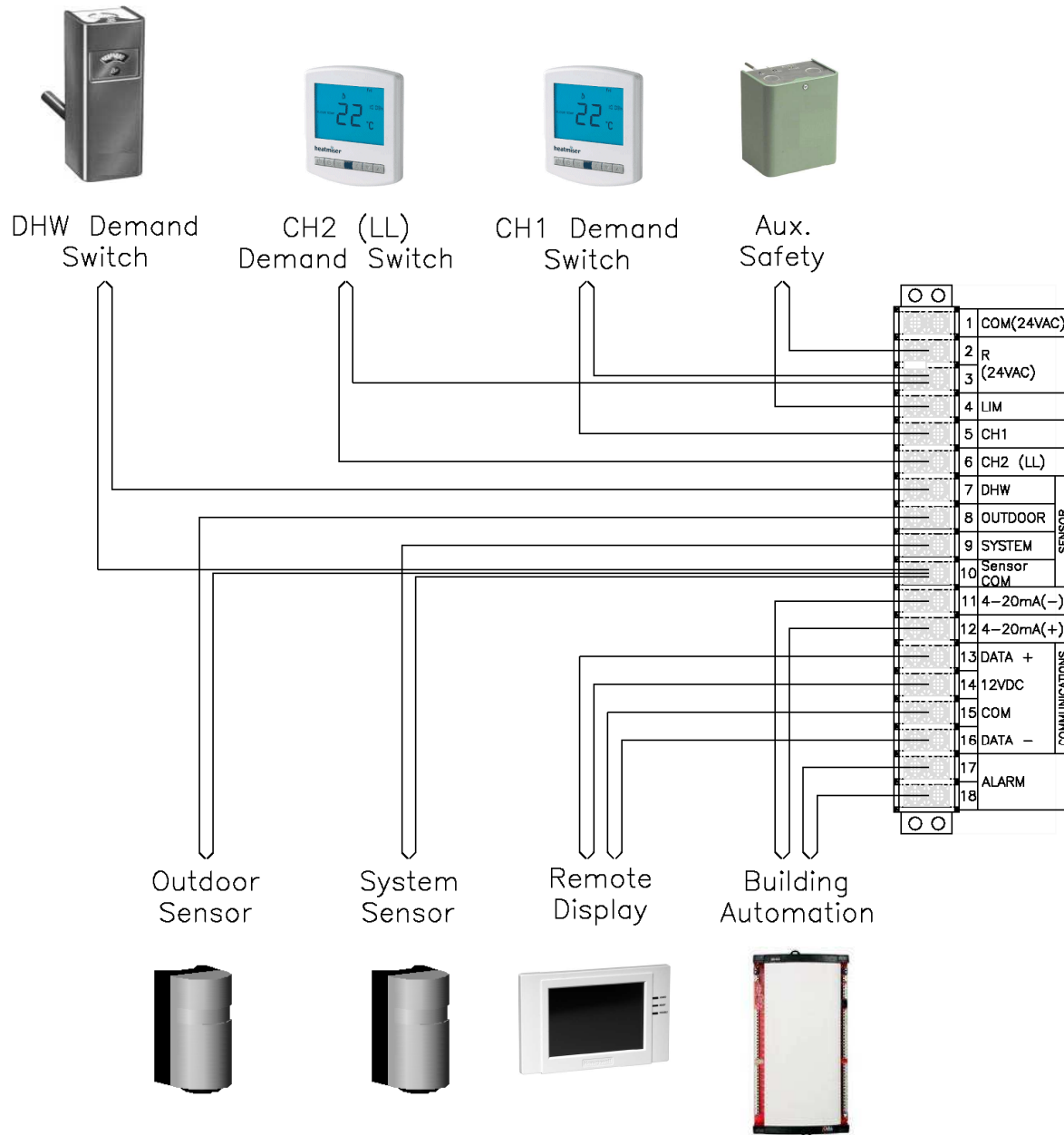

**Figure 3-3 All Models  
DHW Input Contacts  
(Large DHW Requirements)**

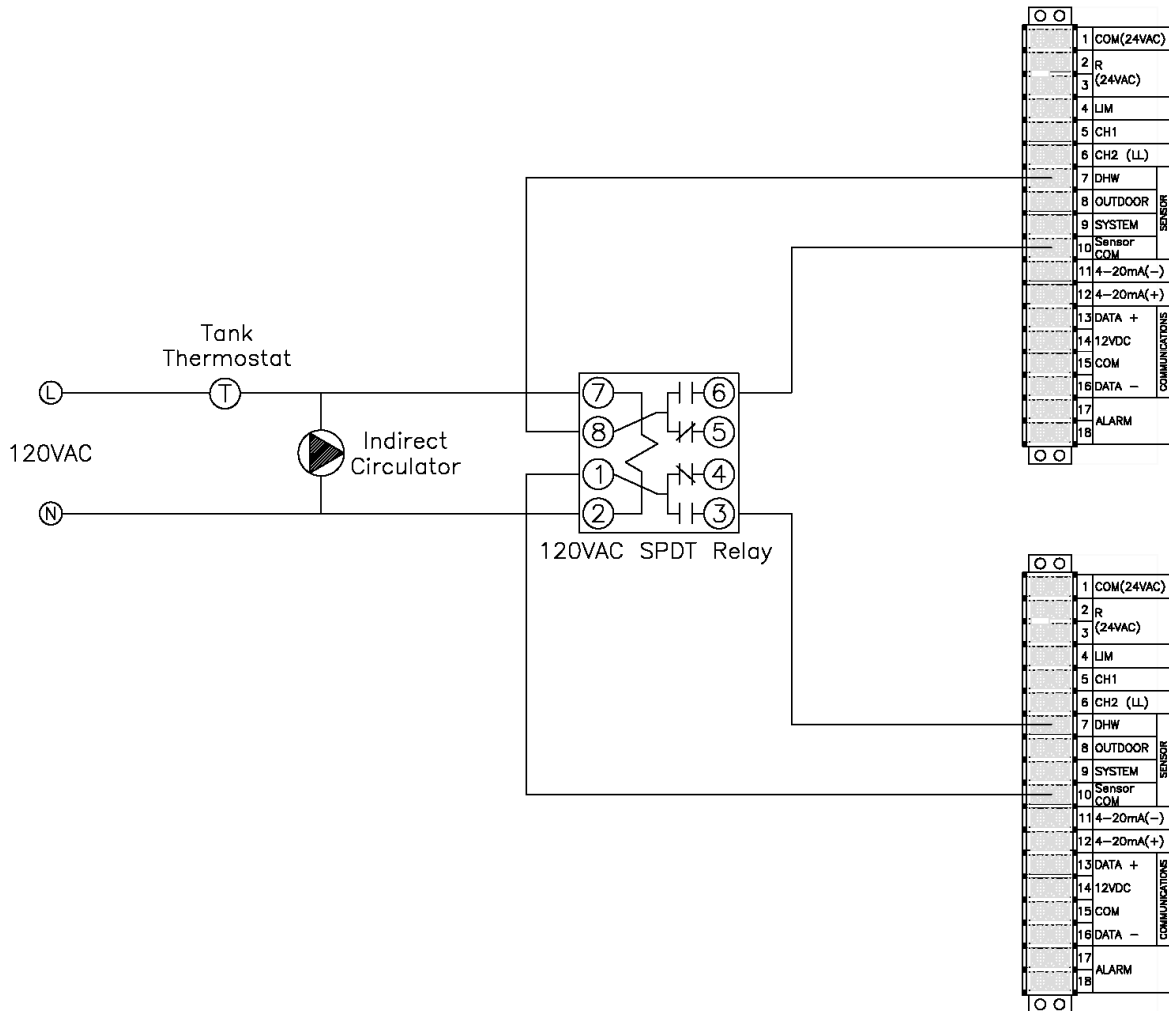
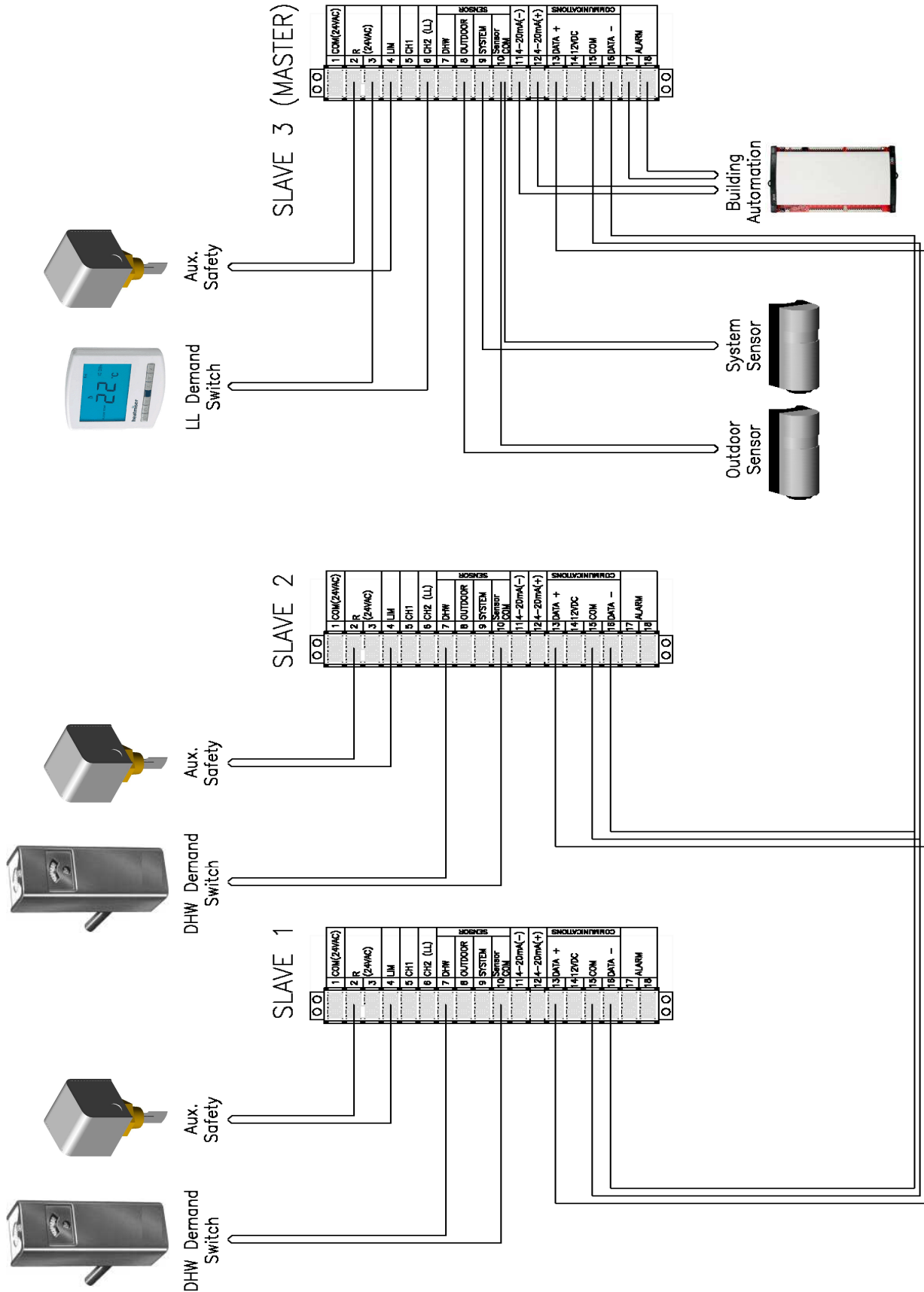

Figure 3-4 All Models  
Low Voltage Field Wiring  
(Multiple Boiler Lead-Lag Configuration)





NY Thermal Inc. 65 Drury Cove Road Saint John, NB E3H 2Z8 Canada  
Technical Assistance: 1-800-688-2575  
Website: [www.nythermal.com](http://www.nythermal.com)  
Fax: 1-506-432-1135