

NTI – MATRIX

INSTALLATION AND OPERATING INSTRUCTIONS

VERSION DATE: 9-15-10

TABLE OF CONTENTS

1.0 SPECIFICATIONS.....	3
2.0 INSTALLATION REQUIREMENTS	4
3.0 VENTING	6
4.0 CONDENSATE DRAIN	13
5.0 INSTALLING GAS PIPING	14
6.0 BOILER PLUMBING	16
7.0 DOMESTIC HOT WATER SYSTEM.....	24
8.0 WIRING	28
9.0 CONTROL SETUP	33
10.0 MATRIX BLOWER OPERATION	37
11.0 HEAT RECOVERY VENTILATION.....	39
12.0 LIGHTING BOILER.....	44
13.0 TROUBLE SHOOTING	46
14.0 SEQUENCE OF OPERATION	50
15.0 INSTALLATION CHECKLIST.....	51
16.0 ANNUAL MAINTENANCE AND INSPECTION.....	52
17.0 PARTS LIST.....	55

HAZARD SYMBOL DEFINITIONS



Danger Sign: Indicates a hazardous situation which, if not avoided, will result in serious injury or death.



Warning Sign: Indicates a hazardous situation which, if not avoided, could result in serious injury or death.



Caution Sign plus Safety Alert Symbol: Indicates a hazardous situation which, if not avoided, could result in minor or moderate injury.



Caution Sign without Safety Alert Symbol: Indicates a hazardous situation which, if not avoided, could result in property damage.

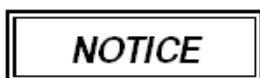

Notice Sign: Indicates a hazardous situation which, if not avoided could result in property damage.



0.0 INTRODUCTION

General Installation Requirements

This document pertains to the correct installation and operation of NTI Matrix appliance, models numbers M100 and M100V. The instructions detailed in this document supersede any and all previous instructions provided by NTI, written or otherwise. Each unit is provided with the following:

- 1) Installation and Operation Instructions,
- 2) Matrix Users Manual, and
- 3) Natural to LP Conversion Kit *

* The conversion kit is required to convert the appliance so it will safely operate with Propane Gas.



Read and understand this entire document prior to proceeding with the installation of the Matrix. Failure to follow the instructions outlined in this document will result in property damage, serious injury or death.

User Responsibilities

This appliance must be installed and serviced by a qualified installer or service technician. This appliance must be serviced and inspected annually when operating in normal residential applications. Demanding applications or extreme conditions (i.e. commercial) may require more frequent service and inspection. As the User/Owner of this equipment, you are responsible for ensuring the maintenance is performed at the required intervals. It is also the Users responsibility to ensure Vent and Combustion-Air Intake termination is kept clear of ice and snow or any other obstruction. Failure to follow these instructions could result in fire, serious injury, or death.



Failure to have the appliance properly serviced and inspected on a regular basis may result in property damage, serious injury or death.



Failure to keep the Vent and Combustion Air Intake clear of ice, snow, and other debris may result in property damage, serious injury, or death.

Installer Responsibilities

As the installing technician it is your responsibility to ensure the installation is performed in accordance with this instruction manual as well as any applicable local or National installation codes. It is also your responsibility to inform the User/Owner of their obligation with respect to the above description under “User Responsibilities”. Failure to follow this warning could result in fire, serious injury, or death.

ATTENTION: LIQUEFIED PETROLEUM (LP) PROPANE

The Matrix is factory set to operate with Natural Gas. **BEFORE OPERATING WITH PROPANE**, the specified LP Conversion Kit must be installed to convert the appliance so it will operate safely with LP Propane.

Liquefied Petroleum (LP) propane gas is heavier than air; therefore, it is imperative that your Matrix unit is not installed in a pit or similar location that will permit heavier than air gas to collect. Local Codes may require appliances fueled with LP gas be provided with an approved means of removing unburned gases from the room. Check your local codes for this requirement.

Natural to LP Propane Conversion Kit

<u>NTI Series</u>	<u>Model Number</u>	<u>Kit Number</u>
Matrix	M100, M100V	82650-1



Failure to use the appropriate Natural to LP Conversion Kit when operating the Trinity Lx with Propane will result in extremely dangerous burner operation leading to property damage, serious injury or death. Refer to section titled **ATTENTION: LIQUEFIED PETROLEUM (LP) PROPANE** for appliance models and corresponding conversion kit numbers.

Appliance Vent / Air-Intake Piping



The Matrix is a “Direct Vent” appliance requiring a “Special Venting System”. Vent and Combustion-Air Intake piping must be piped to the outdoors, using the vent material and rules outlined in these instructions. Failure to follow instructions will result in serious injury or death.

1.0 SPECIFICATIONS

Table 1.1 General Specifications

Model	CSA Input (MBH) ^{1,2}	DOE Heating Capacity (MBH) ^{1,3}	Net I=B=R Rating (MBH) ^{1,3}	DOE AFUE (%) ³	Supply Plenum (inches)	Return Plenum (inches)	Airflow Heating (CFM)	Airflow Cooling (CFM)	Ventilation (CFM)	Dimensions H-W-D (inches)	Vent/Air Size ⁴
M100	25-150	136	118	95.1	22.5x18.5	18x18	400-1200	400-1600	-	53-28-38	3"
M100V	25-150	136	118	95.1	22.5x18.5	18x18	400-1200	400-1600	70-150	53-28-38	3"

Notes:

1 – Listed Input and Output ratings are at minimum vent lengths at Sea Level. Numbers will be lower with longer venting and/or altitudes greater than 2000 feet.

2 – The maximum output when operating on LP-Gas is limited to 145MBH.

3 – Based on rating plate input capacities, using standard test procedures prescribed by the U.S. Department of Energy. Ratings have been confirmed by AHRI (GAMA).

4 – Matrix units require a special venting system, use only vent materials and methods detailed in these instructions.

1.1 High Altitude Operation

The Matrix is designed to operate to capacity in installations at 2000 feet of elevation or less. As elevations higher than 2000 feet have less dense air, the unit is not capable of providing its specified capacity. (See Chart).

In Canada:

De-rate by 5% for altitudes between 2000 and 4500 feet. For altitudes above 4500 feet consult with local authorities.

In USA:

De-rate by 4% for every 1000 feet over 2000 feet.

Figure 1.1 Maximum Capacity vs. Altitude

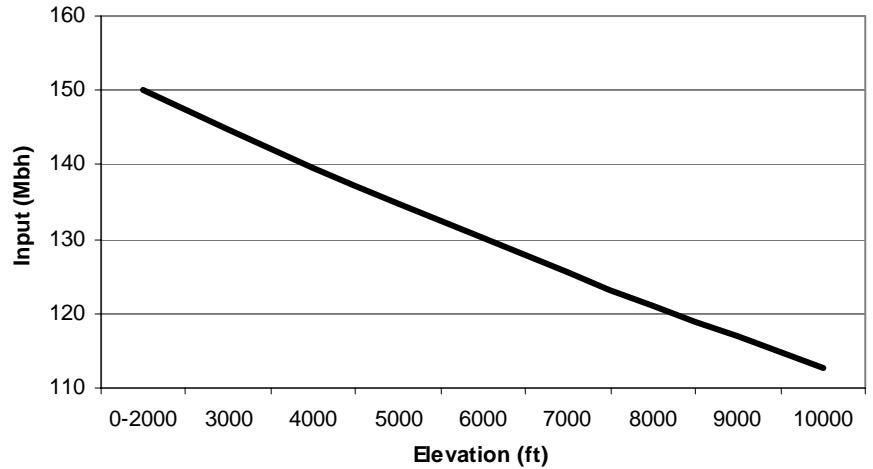

CAUTION

AT ELEVATIONS GREATER THAN 2000 FEET, THE COMBUSTION OF THE MATRIX MUST BE CHECKED WITH A CALIBRATED COMBUSTION TESTER TO ENSURE SAFE AND RELIABLE OPERATION. CONSULT SECTION 5.20 FOR INSTRUCTIONS ON ADJUSTING THE INPUT TO PROVIDE PROPER OPERATION.

IT IS THE INSTALLERS RESPONSIBILITY TO CHECK THE COMBUSTION, AND TO ADJUST THE COMBUSTION IN ACCORDANCE TO SECTION 5.20

2.0 INSTALLATION REQUIREMENTS

The installation of your NY Thermal Matrix gas furnace/boiler must conform to the requirements of your local authority, and the National Fuel Gas Code ANSI Z223.1 and or CAN/CGA B149 Installation Codes. Where required by the Authority, the installation must conform to the standard for “Controls and Safety Devices for Automatically Fired Boilers ANSI/ASME CSD-1.

IMPORTANT

Carbon Monoxide Detectors

Many jurisdictions require the installation of carbon monoxide detectors in buildings where a sidewall vented fuel-burning appliance is installed. Installers must abide by local code requirements regarding the installation of CO detectors. The use of a certified carbon monoxide detector is recommended but not required by NTI.

IMPORTANT

“IN THE STATE of MASSACHUSETTS ONLY”

(a)For all horizontally vented gas fueled equipment installed in every dwelling, building or structure used in whole or in part for residential purposes, including those owned and operated by the Commonwealth and where the side wall exhaust vent termination is less than seven (7) feet above finished grade in the area of the venting, including but not limited to decks and porches, the following requirements shall be satisfied:

1. INSTALLATION OF CARBON MONOXIDE DETECTORS. At the time of installation of the side wall horizontal vented gas fueled equipment, the installing plumber or gas fitter shall observe that a hard wired carbon monoxide detector with an alarm and battery back-up is installed on the floor level where the gas equipment is to be installed and on each additional level of the dwelling, building or structure served by the equipment. It shall be the responsibility of the property owner to secure the services of qualified licensed professionals for the installation of hard wired carbon monoxide detectors.
 - a. In the event that the side wall horizontally vented gas fueled equipment is installed in a crawl space or an attic, the hard wired carbon monoxide detector with alarm and battery back-up may be installed on the next adjacent floor level.
 - b. In the event that the requirements of this subdivision can not be met at the time of completion of installation, the owner shall have a period of 30 days to comply with the above requirements; provided, however, that during said 30 day period a battery operated carbon monoxide detector with an alarm shall be installed.
2. APPROVED CARBON MONOXIDE DETECTORS. Each carbon monoxide detector as required in accordance with the above provisions shall comply with NFPA 720 and be ANSI/UL 2034 listed and IAS certified.
3. SIGNAGE. A metal or plastic identification plate shall be permanently mounted to the exterior of the building at a minimum height of eight (8) feet above grade directly in line with the exhaust vent terminal for the horizontally vented gas fueled heating appliance or equipment. The sign shall read, in print size no less than one-half (1/2) inch in size, **“GAS VENT DIRECTLY BELOW. KEEP CLEAR OF ALL OBSTRUCTIONS”**. *(A plate is included with the boiler)*
4. INSPECTION. The state or local gas inspector of the side wall horizontally vented gas fueled equipment shall not approve the installation unless, upon inspection, the inspector observes carbon monoxide detectors and signage installed in accordance with the provisions of 248 CMR 5.08(2)(a)1 through 4.

(b)EXEMPTIONS: The following equipment is exempt from 248 CMR 5.08(2)(a)1 through 4:

1. The equipment listed in Chapter 10 entitled “Equipment Not Required To Be Vented” in the most current edition of NFPA 54 as adopted by the Board; and
2. Product Approved side wall horizontally vented gas fueled equipment installed in a room or structure separate from the dwelling, building or structure used in whole or in part for residential purposes.

.....Next Page

....Continued.

(c)MANUFACTURER REQUIREMENTS – GAS EQUIPMENT VENTING SYSTEM PROVIDED. When the manufacturer of Product Approved side wall horizontally vented gas equipment provides a venting system design or venting system components with the equipment, the instructions provided by the manufacturer for installation of the equipment and the venting system shall include:

1. Detailed instructions for the installation of the venting system design or the venting system components; and
2. A complete parts list for the venting system design or venting system.

(d)MANUFACTURER REQUIREMENTS – GAS EQUIPMENT VENTING SYSTEM NOT PROVIDED. When the manufacturer of a Product Approved side wall horizontally vented gas fueled equipment does not provide the parts for venting the flue gases, but identifies “special venting systems”, the following requirements shall be satisfied by the manufacturer:

1. The referenced “special venting system” instructions shall be included with the appliance or equipment installation instructions; and
2. The “special venting systems” shall be Product Approved by the Board, and the instructions for that system shall include a parts list and detailed installation instructions.

(e)A copy of all installation instructions for all Product Approved side wall horizontally vented gas fueled equipment, all venting instructions, all parts lists for venting instructions, and/or all venting design instructions shall remain with the appliance or equipment at the completion of the installation.

ATTENTION

LIQUIFIED PETROLEUM (LP) PROPANE

The Matrix is set to operate with Natural Gas; LP Conversion Kit Part No. 82650-1 is included with each furnace and must be installed before operating with Propane.

Liquefied Petroleum (LP) propane gas is heavier than air; it is imperative that your boiler is not installed in a pit or similar location that will permit heavier than air gas to collect. Local Codes may require appliances fueled with LP gas be provided with an approved means, of removing unburned gases from the room.

Check your local codes for this requirement.

2.1 Location

In all cases, the Matrix must be installed indoors, in a dry location, such that the gas components are protected from dripping or spraying water or rain, during operation and servicing. The boiler location ambient temperature is maintained to a minimum of 50°F.

Determine the best location of the vent termination, and if possible locate the appliance as close to the termination point as possible. Ensure that the desired appliance location is not subjected to flooding or high moisture levels, for damage to the appliance will occur, voiding your NY THERMAL warranty.

IMPORTANT

CLEARANCES

For proper and safe installation adhere to the following clearances to combustibles:

<i>Furnace Casing = 0"</i>	Floor = Combustible	Flue Pipe:	Boxed in or enclosed = 2" In free air = 0"
----------------------------	---------------------	------------	---

The following are the minimum clearances recommended for servicing:

Front = 24" Sides = 24"	Back = 6"(optional return plenum location) Bottom = 0"	Top = 12"
----------------------------	---	-----------

3.0 VENTING

The NY Thermal Matrix is a high efficiency condensing gas furnace/boiler utilizing induced power venting. Exhaust gases are to be vented directly outdoors, using the venting method detailed in this section. Under no conditions, may this unit vent gases into a masonry chimney, unless it is vacant, and utilizes Matrix approved venting material as illustrated in the figures in this section.

Attaching Vent Piping to Boiler

It is extremely important for the intake and exhaust piping to be adapted to the appropriate size immediately upon exiting the boiler cabinet. The Matrix comes with a 3" male PVC fitting to connect the air intake port of the boiler. The Matrix exhaust connection is 3" male PVC, use approved cement to connect to venting system. Check the flue outlet gasket for proper insertion and sealing prior to and after attaching the venting. Ensure the venting system does not apply a load or stain on the flue outlet of the boiler (recommend using two elbows to create a "swing joint" as shown above).

Figure 3.1 Venting Construction

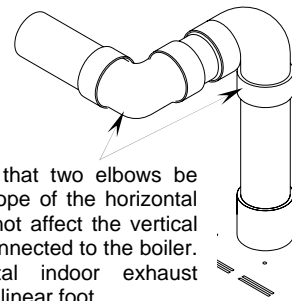
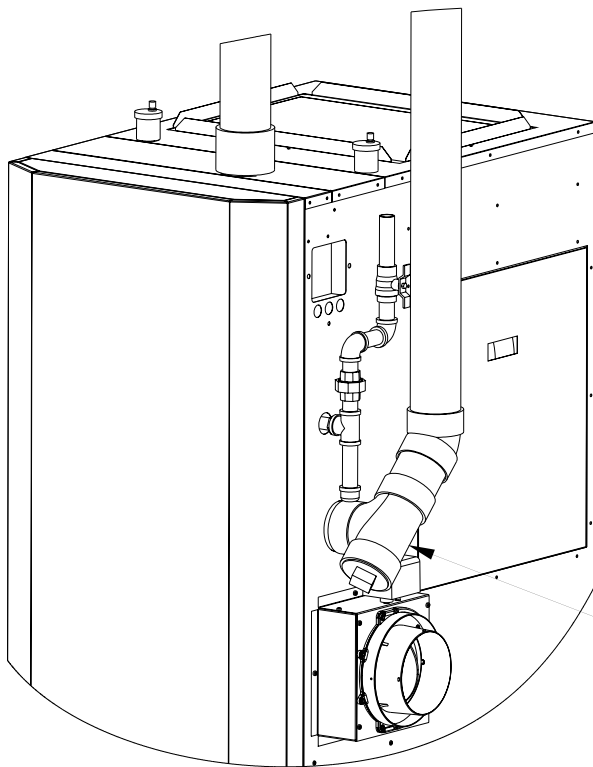

It is recommended that two elbows be used, so that the slope of the horizontal exhaust vent does not affect the vertical plumb of the pipe connected to the boiler. Slope all horizontal indoor exhaust venting $\frac{1}{4}$ " to $\frac{1}{2}$ " per linear foot.

It is recommended to have a collection point for condensation in the intake venting. Condensation can then be drained to an open house drain or condensate pump.

Drain line from intake must have an appropriate trap or shut off valve to avoid siphoning.

IMPORTANT

The vent connection and piping must be perfectly aligned to the furnace connection. AND MUST NOT APPLY ANY WEIGHT OR LATERAL FORCE TO THE FLUE BOX. NTI does not warranty damages to the flue box.

NOTICE

In Canada, the first **3 ft (915 mm)** of vent piping must be readily accessible for inspection.

3.1 Vent/Air-Intake Pipe Material

Table 3.1 Acceptable Vent and Air-Intake Pipe Material

Items ¹	Materials ^{2, 3}	Installation Standards		
		United States	Canada ⁴	
Vent Pipe and Fittings	PVC - DWV	ANSI/ASTM D2265	All venting material in Canada must be ULC S636 approved . See Note 4 below for appropriate temperature applications.	All plastic Vent materials installed on gas fired appliances in CAN/US must meet the Standards listed in Table 3.1. Failure to comply could result in fire, serious injury or death.
	PVC Schedule 40	ANSI/ASTM D1785		
	CPVC Schedule 40	ANSI/ASTM F441		
Pipe Cement	PVC	ANSI/ASTM D2564		
	CPVC	ANSI/ASTM F493		
Primers	PVC / CPVC	ANSI/ASTM F656		

Notes:

- ¹ Refer to Table 3.2 for Allowable Vent and Air-Intake Pipe Sizes and Lengths.
- ² Closet/alcove installations in US and Canada require approved **CPVC** vent pipe, fittings, cements, and primers.
- ³ The Air-Intake does not require high temperature pipe material. Check applicable local codes for acceptable materials.
- ⁴ ULC S636 PVC is approved for flue gas temperatures up to 149°F (65°C) and must only be used for low temperature applications. High temperature applications requiring appliance supply water temperatures greater than 140°F (60°C) must use ULC S636 approved CPVC.

Mandatory Pre-commissioning Procedure for Plastic Venting



Do not apply power to the appliance prior to Step 4 in the Mandatory Pre-commissioning Procedure for Plastic Venting.

1. Working with the power turned off to the appliance, completely install the vent and air intake system, securely cementing joints together. If possible, allow primers/cements to cure for 8 hours before firing the burner. If curing time is less than 8 hours, proceed with Steps 2 through 6.
2. Maintain the appliance gas supply shut-off valve in the off position.
3. Disconnect electrical leads to the Hot Surface. Ensure the cables are placed in a fashion where they will not arc to ground or other conductor.
4. Turn power on to the appliance and apply a heat demand.
5. Allow for 3 complete trials for ignition, consisting of pre and post purge of the combustion blower, until an ignition lockout occurs. Repeat the process two more times (i.e. 9 complete ignition sequences in total).
6. Turn power off and reconnect the electrical leads to the Igniter.

3.2 Venting Configurations

3.2.1 Two-Pipe Vent Termination

Figure 3.2 Two-Pipe Vent Termination

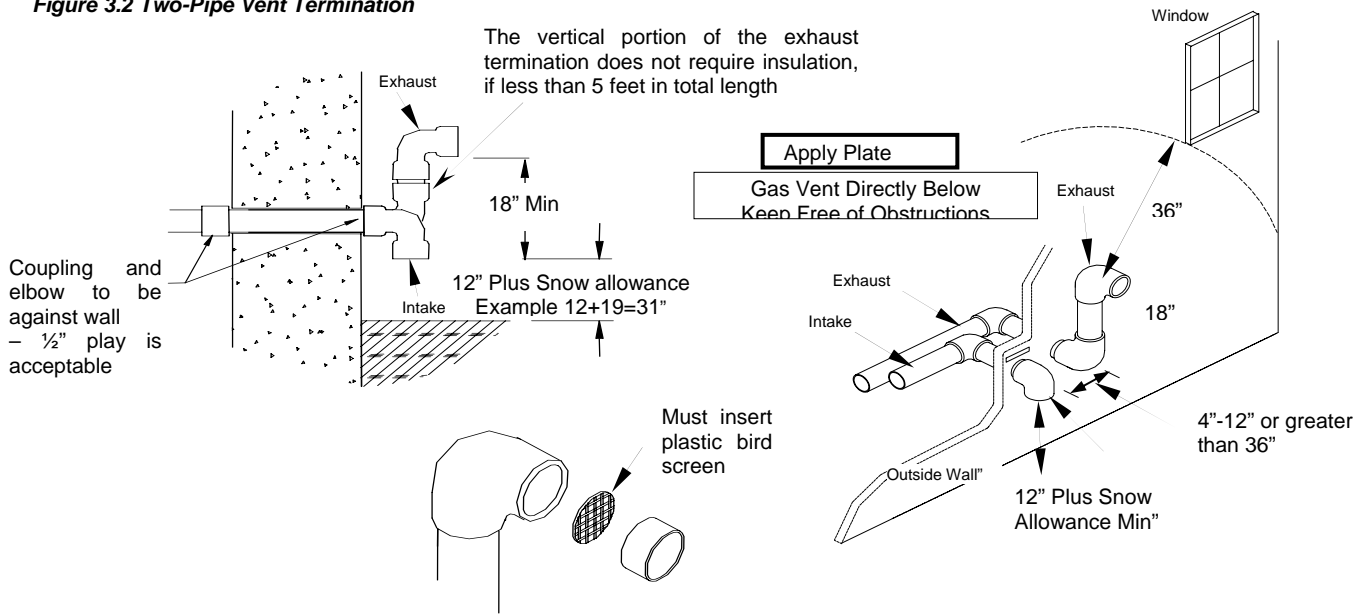

3.2.2 Concentric Vent Termination (No longer approved for Canada)

Figure 3.3 Concentric Vent Termination

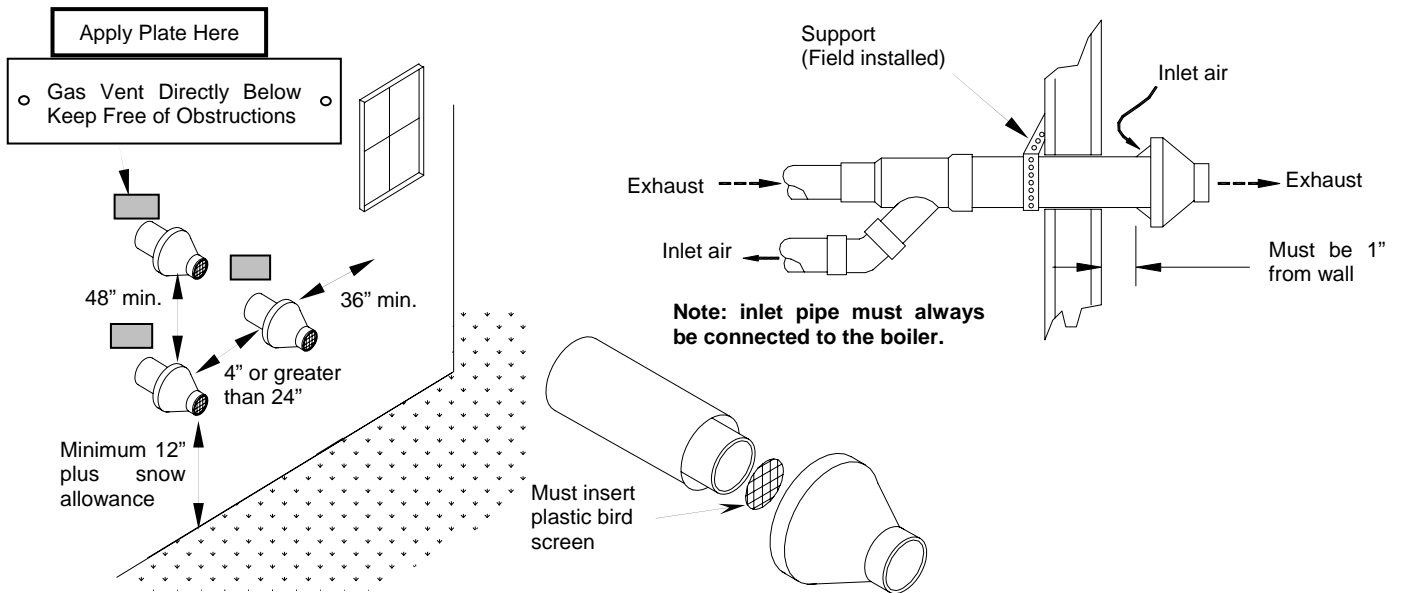

Use NTI part # 82666 or York part # 1CT0303

Instructions included with vent terminal contain more detailed assembly and installation instructions.

Clearances and requirements of this manual supersede those of the instructions included with the vent terminal.

Terminal must be cemented together during installation.

3.2.3 Roof Venting

Figure 3.4 Roof Venting

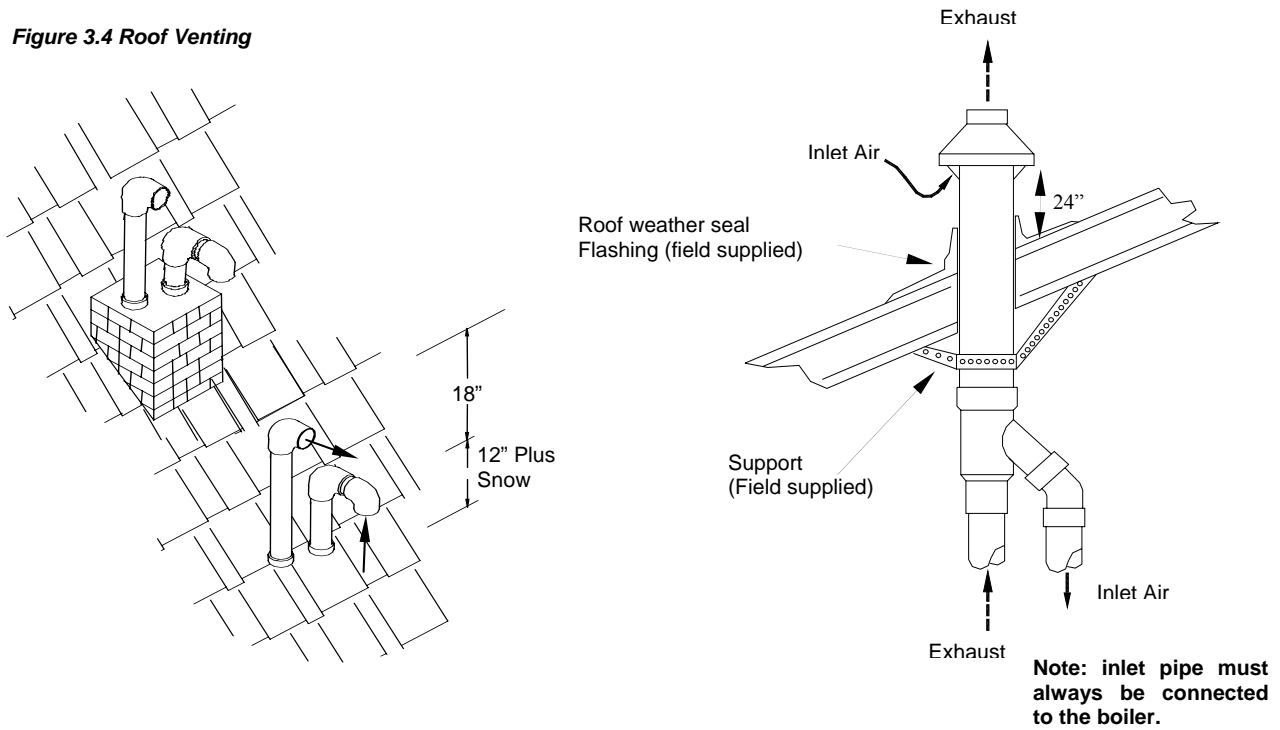

IMPORTANT

USE OF EXISTING CHIMNEY

It is permissible to run vent pipe through an existing chimney as long as:

1. The chimney is not to be used by any other appliance.
2. Flue gases don't enter the vacant chimney.
3. Only Trinity certified venting materials are used, see Section 3.1.
4. Vent lengths are within the maximums specified.

3.3 Venting Rules and Guidelines

1. It is highly recommended that the vent terminal be located where it will not be exposed to normal prevailing winds.
2. The exhaust must be a minimum of 18" above the air inlet, and the air inlet must always be a minimum of 12" plus snow allowance above any surface that will support snow. (Two feet plus snow allowance is highly recommended). Consult your weather office for the maximum typical snowfall for your region. Example: New Brunswick Canada the typical maximum snowfall is 19", Thus in figures of Section 3.3, the inlet must be $(12''+19'') = 31''$ off the ground, the exhaust must be $(31''+18'') = 49''$.
3. Under normal operating conditions this appliance will produce a plume of white gases, and should be taken into consideration when selecting an adequate location. A 3' diameter stainless, plastic, or vinyl shield can be used to flash the exterior of the residence.
4. If the horizontal distance between the inlet and exhaust is more than 12", increase minimum vertical separation by the same amount. (If horizontal distance is greater than 6', no additional vertical spacing is required). Example, horizontal separation equal to 24" requires a minimum vertical separation of $18''+(24''-12'')=30''$. (Vertical separation is never required to be greater than 36")
5. Elbows on outside of wall must be no greater than 1/2" away from the wall.
6. All indoor exhaust piping must be on a slope back to the boiler a minimum of 1/4" per linear foot of vent. For applications where excessive condensation is possible 1/2" per linear foot is recommended. (See illustration in Figure 3.1)
6. Exhaust vent pipe can be secured to the wall for more rigidity.
7. In all roof applications the discharge must point away from the pitch of the roof.
8. Install adequate flashing where the pipe enters the roof, to prevent water leakage.
9. Install and seal a rain cap over existing chimney openings, in vacant chimney applications.
10. For installations that exit the wall below grade. Excavate site as shown in Figure 3.5, to a point below where the pipes are to exit. Ensure that the wall is fully sealed where the pipes penetrate the wall. The vent piping **MUST** be secured to the side of the building above grade, as shown, to provide rigidity. NTI provides a mounting bracket, PN:82075, for securing the exhaust pipes. Ensure that the vent clearances are maintained (Inlet minimum 12" plus snow allowance from grade, exhaust outlet 18" minimum above inlet)
11. Install the vent screens provided into both the inlet and exhaust vent terminal elbows. The screen must be on the outside of the last elbow. Install the screen into the female opening of the elbow. Then cut a small piece of pipe to sandwich the screen into the elbow. NOTE be sure that the small piece of pipe cut, does not extend past the end of the elbow. Two screens are provided in the package.
12. It is extremely important that the intake and exhaust piping be adapted to the appropriate size immediately upon exiting the boiler cabinet.
13. All interior vent pipe shall be supported a minimum of every 36".

Figure 3.5 Installing Venting Below Grade

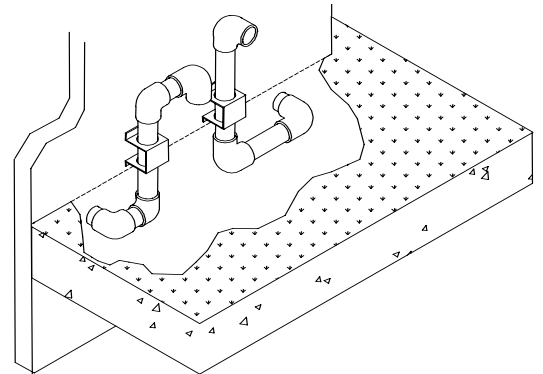

3.4 Venting Clearances

These are code restrictions for the location of the Flue gas vent terminal. Compliance doesn't insure a satisfactory installation; good common sense must also be applied.

The vent terminal shall not terminate:

1. Directly above a paved sidewalk or a paved driveway that is located between two buildings, and that serves both buildings;
2. Less than 7 feet above grade where located adjacent to a paved walkway or driveway located on public property.
3. Within 3' (three feet) of a window or door that can be opened, or non-mechanical air supply inlet to any building.
4. Within 6' of a mechanical air supply inlet to any building, or roof eve containing soffit openings.
5. Above a meter/regulator assembly within 3' horizontally of the vertical centerline of the regulator.
6. Within 3' horizontally of any gas service regulator vent outlet up to a height of 15'.
7. Less than 30" plus snow allowance above grade, or any surface that will support snow, ice, or debris. The exhaust must be a minimum of 18" above the air inlet, and the air inlet must always be a minimum of 12" plus snow allowance above any surface that will support snow. (Two feet plus snow allowance is highly recommended). Consult your weather office, for the maximum typical snowfall for your region.
8. Underneath a wooden verandah, porch, or deck.
9. Underneath cement verandah, porch, or deck, unless both ends are open and the exhaust pipe is installed at least 24" under the deck floor.
10. So situated that the flue gases are directed towards brickwork, siding, or other construction, in such a manner that may cause damage from heat or condensate from the flue gases.
11. Less than 3' from an inside corner of an L-shaped structure (including walls and fences).
12. Install the warning plate "Gas Vent Directly Below" 4 feet above the location of the air inlet pipe, so it is visible from at least eight (8) feet away (Plastic Label included in the Installation Manual Package – see figure).

3.5 Determining Vent Lengths

Use the following chart to determine the maximum amount of vent pipe that can be used. This chart calculates, sweep and 45° elbows, and 90° elbows at 5 equivalent feet. Note: chart shows allowable equivalent vent lengths for intake and exhaust vents separately, thus an M100V operating on Natural Gas can be installed with 105 equivalent feet of intake venting and 105 equivalent feet of exhaust venting.

IMPORTANT

The length of one vent pipe (intake or exhaust) may not exceed the length of the other vent pipe by more than 20 equivalent feet.

The three 90° elbows of the exterior vent piping (two outlet, and one inlet) do not have to be included, as they are taken into consideration in the vent calculations.

Propane Gas (LP) maximum vent length cannot exceed 50 equivalent feet.

Table 3.2 Maximum Vent Length

Model	Vent Size	Gas	Max. Equiv. Length	Number of Elbows or 45's								
				1	2	3	4	5	6	7	8	9
M100	3"	Natural	105	100	95	90	85	80	75	70	65	60
M100V	3"	LP	50	45	40	35	30	25	20	15	10	5

3.6 Outdoor Venting

Vent piping outside the building is permitted under the following conditions:

- The maximum length outside the building is 20 feet. (Outdoor length must be included in the overall vent length calculation.)
- All normal termination clearances are maintained.
- All exterior exhaust vent pipes are insulated with 3.5"-ID, ½"-thick, Closed Cell Foamed Polyolefin Tubing i.e., "Tundra Seal Plus" or equivalent.
- The pipe is supported every 24"
- The exhaust and inlet are sloped back to the boiler ½" elevation for every foot.

Figure 3.6 Outdoor Venting

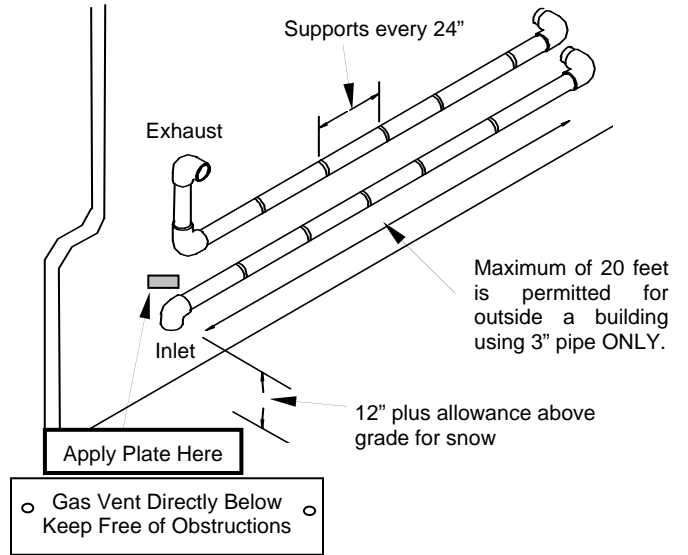

4.0 CONDENSATE DRAIN

This unit produces water as a product of combustion. Much of this water condenses on the heat exchanger and in the venting system. All exhaust piping must be on a slope back to the boiler $\frac{1}{4}$ " per linear foot of vent. Steps must be taken to ensure that condensate does not collect in the venting system. Condensate must be drained from the boiler into a household drain.



WARNING

FAILURE TO PROPERLY CONNECT THE CONDENSATE LINE WILL CAUSE COMBUSTION GASES TO ENTER THE ROOM, POSSIBLY CAUSING SERIOUS INJURY TO OCCUPANTS OR DEATH.

Note: check with your municipality, or local gas company to determine if disposal of combustion condensate is permitted. In the State of Massachusetts the condensate must be neutralized prior to entering a drain.

The following are important notes that must be taken into consideration when constructing the condensate system:

- DO NOT run condensate line outside. A frozen or blocked drain will cause the condensate to fill the combustion chamber. This will result in a no heat condition, as the unit will shut down, and damage to the flame sensor, and components can occur.
- NEVER use copper, steel, or galvanized piping in the construction of the condensate system (condensate is very corrosive and will wrought most metals).
- When a condensate pump is used or required, select a pump that is designed for residential furnaces.

Figure 4.1 Condensate Drain Plumbing

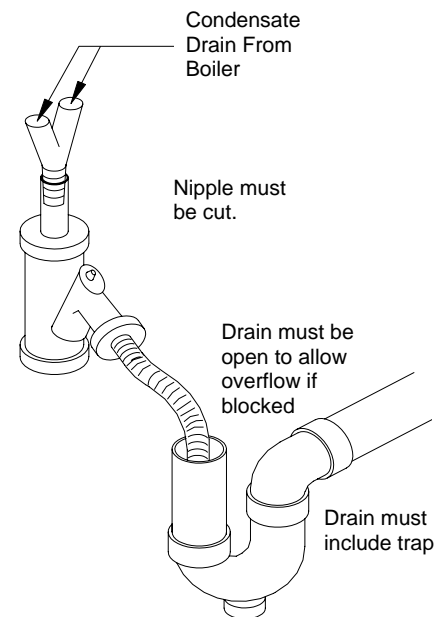

5.0 INSTALLING GAS PIPING

5.1 Installation

Refer to the current National Fuel Gas Code ANSI Z223.1/NFPA 54 or CAN/CGA B149.1 installation codes, and local codes for gas piping requirements and sizing.

Pipe size running to the unit depends on:

- Length of pipe.
- Number of fittings.
- Type of gas.
- Maximum input requirement of all gas appliances in the residence.

Ensure that:

- Flexible gas pipe is used (if acceptable by local codes). The gas valve and blower cannot support the weight of piping, leading to blower vibration and damaged components. If rigid piping is used, ensure that the valve supports **NO WEIGHT**
- You plan the installation so that the piping does not interfere with the vent pipe, or the removal of the valve, burner, and serviceable components.
- The Boiler shall be installed such that the gas ignition system components are protected from water (dripping, spraying, rain etc.) during installation and servicing.
- The gas piping is large enough for all the appliances in the home. No appreciable drop in line or manifold pressure should occur when any unit (or combination of units) lights or runs.
- Always use a pipe-threading compound that is resistant to propane (LP) gas solvent action. Use sparingly to all male threads, starting at two threads from the end. Over doping or applying dope to the female end, can result in a blocked gas line.

DO NOT TIGHTEN FITTINGS WITHOUT SUPPORTING THE GAS VALVE as damage to the valve or motor can occur. Install a manual “equipment Shut-Off Valve” as shown. Valve must be listed by a nationally recognized testing lab.

Figure 5.1 Gas Inlet Connection

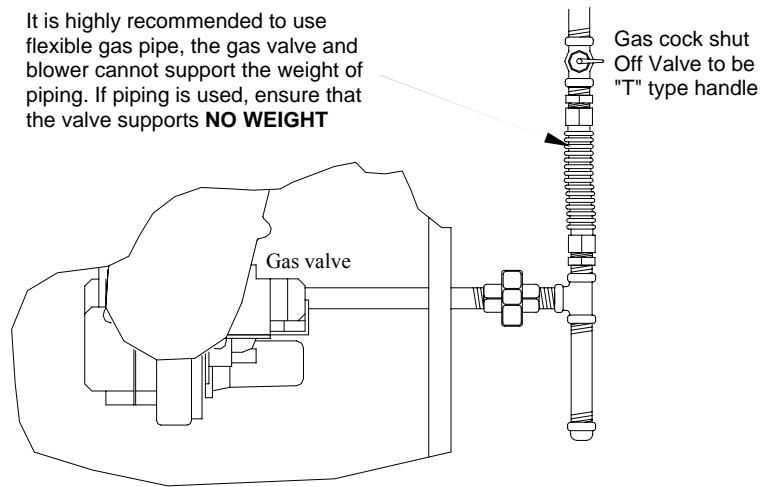

5.2 Testing and settings

Gas line and regulator(s) must be able to support a line pressure at the gas valve of 4-9”w.c for Natural Gas and 9-12”w.c for LP while running at maximum rate. Matrix gas valves are equipped with two bleed ports to measure Line and Manifold pressure.

Note: Line pressure adjustments can only be made at the gas regulator, NOT AT THE GAS VALVE.



WARNING

IF LINE PRESSURE EXCEEDS ½ PSI (14 INCHES W.C.) COMPLETELY DISCONNECT LINE TO GAS VALVE. THIS EXCESSIVE PRESSURE CAN DAMAGE VALVE, CAUSING A LEAK RESULTING IN FIRE OR EXPLOSION.

Matrix Installation and Operation Instructions

The gas valve is equipped with a throttle/input adjustment screw. The input screw “MUST NEVER BE ADJUSTED” without verifying proper combustion with a calibrated combustion analyzer.

Figure 5.2 Setting Combustion

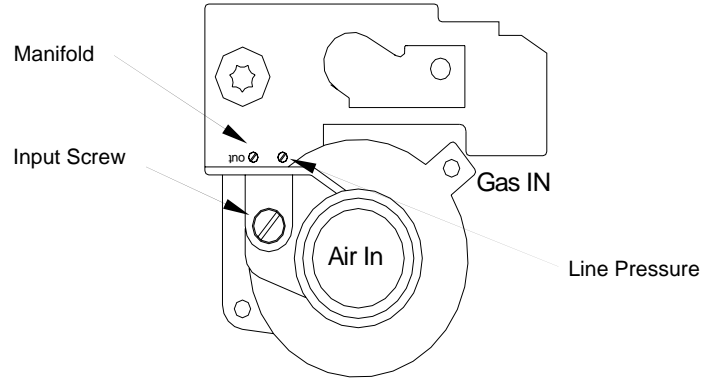

CAUTION

The Matrix is tested with Natural Gas having a heating value of 1020 BTU per cubic foot. For areas with lower heating values, a combustion test is required to obtain optimum operation.

Using a calibrated flue gas analyzer, check the combustion and compare it with the acceptable requirements. The test should be performed at maximum fan speed (“Gas Input Value”).

Adjusting Combustion - Use the input screw to adjust the amount of gas available for combustion. Increasing gas increases CO and CO₂. Reducing gas decreases CO and CO₂.

CO – At maximum fan speed, the CO reading is the most critical to the safe operation of the boiler. The CO should be no higher than 175 PPM at any condition. If the CO is over 140 PPM, the input should be reduced until the CO is less than 140 PPM or the CO₂ is reduced to 8% (9% for LP Gas). If the CO is over 140 PPM and the CO₂ is less than 8% (9% for LP Gas), contact NTI for assistance.

Table 5.1 Normal Range of Combustion Products (At maximum fan speed, 240)

	Natural	Propane
Carbon Dioxide CO ₂ %	8-9.5*	9-10.5*
Carbon Monoxide CO ppm	25-175*	25-175*
NO _x ppm	10-50	10-50

*Note: On colder days CO₂ should be closer to the lower number, on warmer days it should be closer to the higher number. CO should be highest at the maximum firing rate.

CO – At minimum fan speed, should be checked, and the CO should be less than the reading recorded at high fan speed. The CO₂ at low fan speed must not be at least as high as the CO₂ recorded at high fan speed, but not more than 9.5% (10.5% for LP Gas).

Figure 5.3 Gas Input Screw Adjustment

Input Screw – Is a multiple turn needle valve. Fully open to close is approximately 17 turns. Typical adjustment for Natural Gas is 0-1 full turns in or out. Typical adjustment for LP Gas is 0-3 full turns in or out (after conversion is performed).

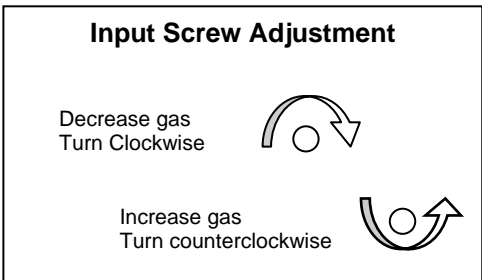
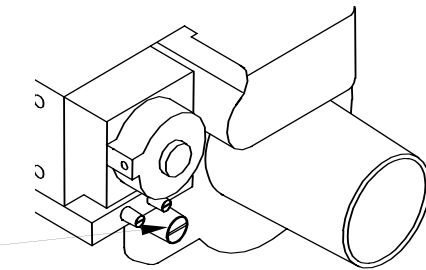

ATTENTION

IF FOR ANY REASON THE INPUT SCREW IS ADJUSTED, A “COMBUSTION ANALYZER” MUST BE USED TO ENSURE SAFE AND PROPER OPERATION.

6.0 BOILER PLUMBING

WARNING

THIS APPLIANCE CONSISTS OF A “LOW-MASS” BOILER AND MUST HAVE ADEQUATE WATER FLOWING THROUGH IT WHENEVER THE BURNER IS ON. FAILURE TO DO THIS WILL DAMAGE THE UNIT AND VOID THE WARRANTY. PLUMBING MUST INCORPORATE A PRESSURE REGULATING FILL VALVE AND PRESSURE RELIEF VALVE.

WARNING

HYDRONIC SYSTEMS, OLD AND NEW, MUST BE FLUSHED TO REMOVE SEDIMENT, FLUX, FILINGS, ETC. FAILURE TO DO SO WILL SERIOUSLY DAMAGE THE BOILER, VOIDING WARRANTY. (CLEAN WITH FERNOX CLEANER F3, NTI PART NUMBER: 83449.)

WARNING

WATER WITH A TOTAL HARDNESS GREATER THEN 100PPM (6 GRAINS/GALLON) MAY RESULT IN HEAT EXCHANGER FAILURE AND WILL VOID YOUR NTI WARRANTY. TREAT ALL SYSTEMS WITH FERNOX PROTECTOR F1 (NTI PART NUMBER: 83448), WHICH IS INCLUDED WITH THE MATRIX PACKAGE.

WARNING

THE BOILER FITTINGS CAN'T SUPPORT ANY WEIGHT. SUPPORT ALL OF THE PLUMBING SYSTEM EXTERNALLY.

DO NOT APPLY TORQUE TO THE PLUMBING FITTINGS. HOLD THE FITTING WHEN INSTALLING, OTHERWISE DAMAGE TO THE UNIT WILL OCCUR.

CAUTION

This appliance is designed to operate in residential and commercial heating systems, and is not intended for:

1. Outdoor installations, or unheated spaces, which can cause freezing.
2. Process heating of potable water, or any other fluids.
3. Un-pressurized, and gravity feed heating systems.
4. Heating systems with very low pressures or flow.

IMPORTANT

1. Understand and follow the plumbing requirements provided in this section.
2. Keep serviceability in mind when installing plumbing around the furnace cabinetry.
3. Install fittings that will allow the system to be flushed if needed during annual check-ups.
4. Add inhibitor, Fernox Protector F1 (NTI Part Number: 83448), to the system water to help prevent limestone and magnetite deposits, and galvanic corrosion. Bottle provided will treat an average 100-liter (26 US gallon) system.

6.1 Plumbing (Minimum Requirements)

Pressure Regulator “Fill Valve” (Supplied): The Matrix operates as a boiler to provide heat, thus it must be installed and operated as such. A 12-15 PSI pressure regulator is provided with the Matrix and must be field installed as per the installation instructions. Note: Local authorities may require the installation of a certified “back-flow preventer” immediately before the pressure regulator.

Circulating Pump (Supplied): The Matrix has a built-in circulator to pump water from the boiler to either the internal forced-air heating coil or the internal domestic coil (brazed plate heat exchanger). An external circulator is only required if the Matrix is also being used to supply heat to a hydronic heating system, the external circulator must be sized for the requirements of the hydronic heating system.

Relief Valve (Supplied): A 30PSI Relief Valve is provided with the system, it is to be mounted with the discharge in the horizontal. Ensure that the discharge is piped to a location where steam or water won’t cause personal injury or appliance and property damage.

Air Purging (Supplied): Boilers are designed to operate with airless water in the system. The Matrix design allows for the evacuation of air from the internal plumbing. For installations in conjunction with a hydronic heating system an Air Scoop, installed as shown in the following diagrams, must be installed to remove air as it circulates through the system. If air continues to be a problem an air scrubber must be used (recommend Spirovent # VJR 100TM).

Expansion Tank (Supplied): The Matrix comes with a built-in expansion tank that is sized to handle the volume of water in the Matrix unit. An external expansion tank must be field sized, supplied and installed for Matrix units installed in systems with hydronic heat.

Low Water Cutoff: A certified LWCO is not provided in the package, however one is to be field installed in any application where the Matrix boiler is located above the radiation or where local authorities require it. Ensure that the water line of the “Low Water Cutoff” is at least 6” above the top of the boiler.

It is recommended that the LWCO be situated so that it can be tested without removing water from the Matrix. Tri-cocks and a gauge glass are highly recommended.

NTI recommends against the installation of isolation valves between the LWCO and the Matrix.

Use the normally open contacts of the LWCO to break 24V to the burner circuit (See Wiring Diagram).



CAUTION

DAMAGE WILL OCCUR IF THE BOILER IS FIRED WITH NO WATER IN IT, OR REPETITIVE NO FLOW OPERATIONS, WHICH WILL VOID THE WARRANTY.

6.2 Matrix Boiler Connections

Figure 6.1 Boiler Feed Water Connections

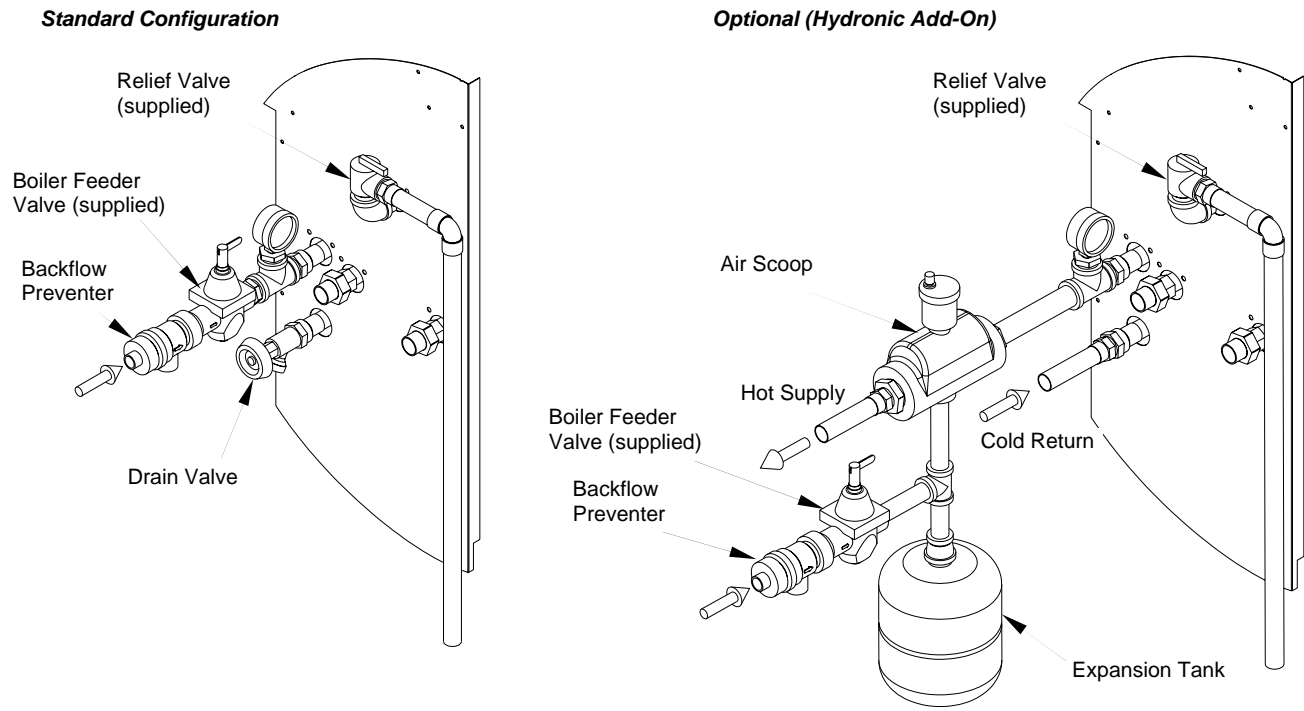

IMPORTANT

Expansion tank and air removal device for the internal functions of the Matrix are included and provide only enough capacity for these functions.

Additional secondary systems require appropriately sized air removal and expansion capability.

6.3 Hydronic Heating Additions (Optional)

ATTENTION

1. **LOW TEMPERATURE APPLICATIONS** (i.e., In-floor) require the use of mixing controls such as a Tekmar injection system or thermostatic mixing valves (See 6.2.3 to 6.2.4). During a call for "Forced-Air Heat" the Matrix will operate at a constantly varying boiler water temperature, this temperature may at times exceed the maximum allowable temperature for some or all of the hydronic zones.
2. **HI TEMPERATURE APPLICATIONS** (i.e., finned tube baseboard) do not require mixing controls, however, when the Matrix is operating during a call for Forced-Air Heat the hydronic system will only receive the heat leftover from the Matrix air handler; keep this in mind during system sizing and design.
3. In applications that do not use zone valves it is important to incorporate into the system design means necessary to prevent **THERMAL SIPHONING**. Note: the following drawings are to be used as a reference only for the system designer.

The Matrix provides heat to hydronic heating systems in two ways:

1. **Hydronic Call** (24 VAC @ H without a call for forced air heating) – A boiler demand is initialized by sending a ‘Hydronic Demand’. The boiler will then maintain a set point of ‘HYD’ (See Table 9.3).
2. **Hydronic Shared Call** (24 VAC @ H concurrent with a forced air call) – With this demand the forced air system is given priority. The set point temperature will be the higher of the ‘HYD’ setting or the forced air set point. During a shared call the hydronic system can only receive the water temperature returning from the fan coil.

If, during a shared call, the boiler can not supply enough heat to maintain a minimum plenum air temperature of 95°F, the Fan Controller will shut-off the hydronic loop using the N.O/N.C contacts on the terminal board until the forced air temperature recovers.

The Matrix has a Grundfos 15-42 built into the primary loop. Given the head loss of the primary loop, the flow rate is fixed at 5 gpm. When designing any secondary heating system it is important to allow for an increase boiler set point to ensure full capacity of the secondary system. This may necessitate the use of mixing valve to protect the secondary from elevated water temperatures.

Example: For a 75,000 Btu/hr secondary system with a desired water temperature of 110°F and 20° ΔT the flow rate will required is BTU/hr/(500* ΔT) or 75,000/(500*20) = 7.5 gpm. Since this exceeds the flow rate in the primary loop, a higher boiler ΔT will be required to maintain the desired 110°F. This is calculated as follows:

$$\begin{aligned} \Delta T_{\text{boiler}} &= \Delta T_{\text{secondary}} * \text{gpm}_{\text{secondary}} / \text{gpm}_{\text{primary}} \\ &= 20 * 7.5 / 5 \\ &= 30^{\circ}\text{F} \end{aligned}$$

Adding the ΔTboiler to the return water temperature of 90°F (110°F-20°F) gives a required ‘HYD’ set point of 120°F.

6.3.1(A) Multiple High Temperature Zones (Zone Valves)

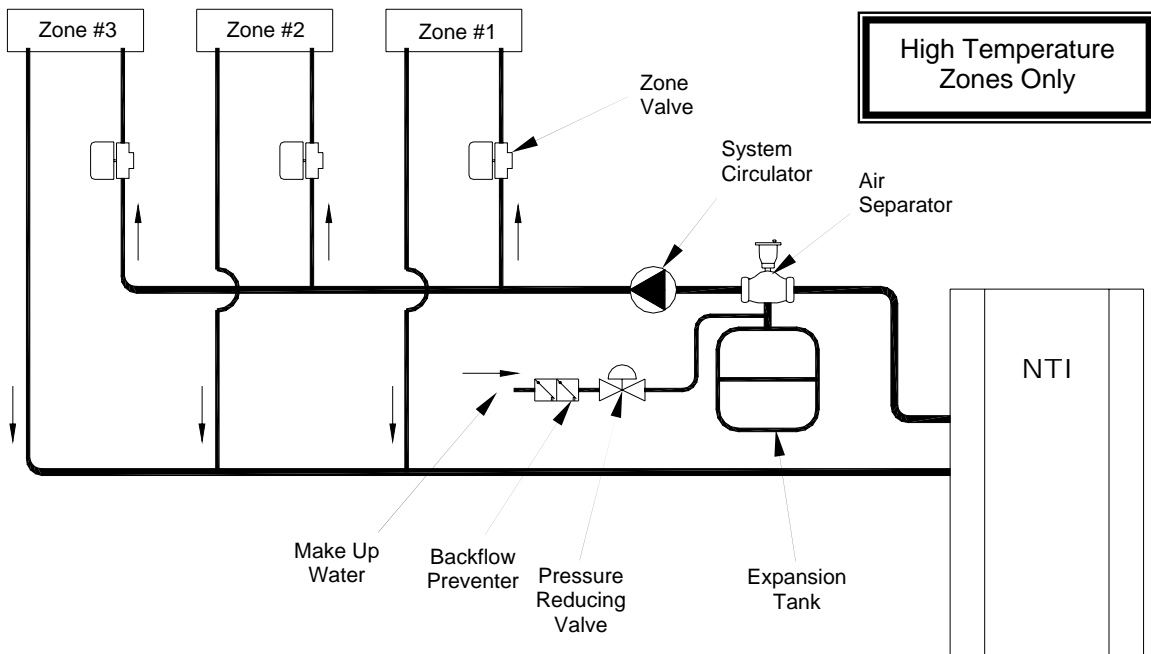

6.3.1(B) Multiple High Temperature Zones (Zone Valves) – Wiring w/ Zone Controller

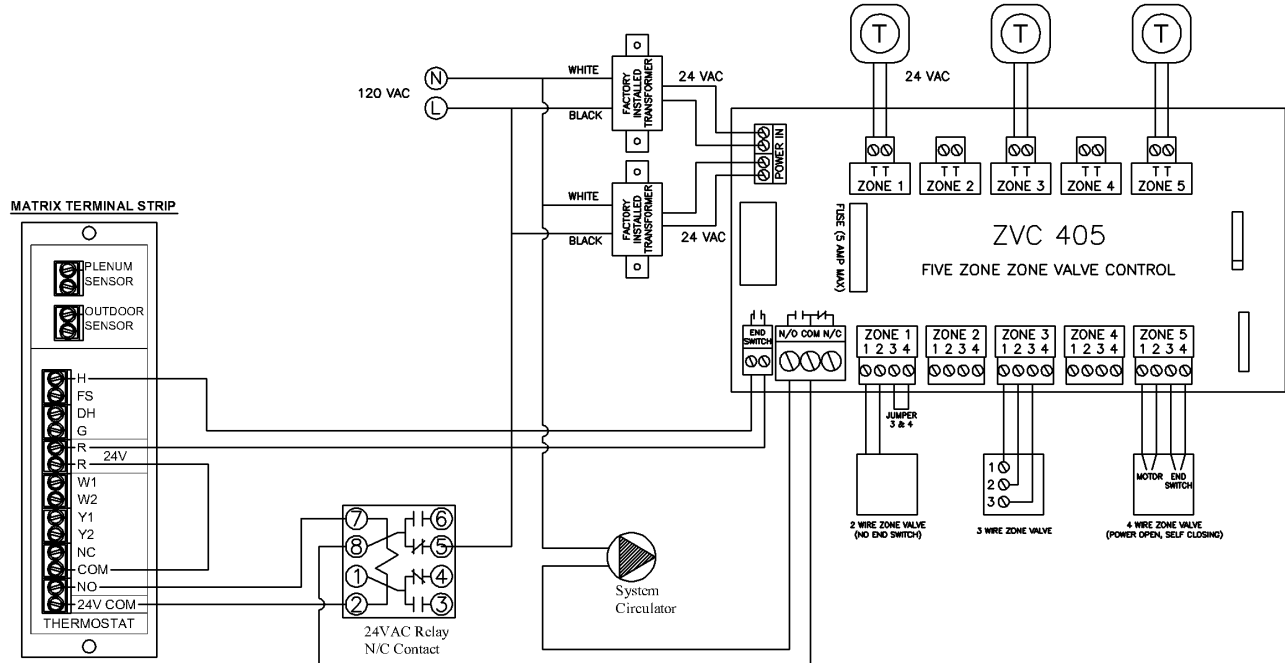

6.3.1(C) Multiple High Temperature Zones (Zone Valves) – Wiring w/o Zone Controller

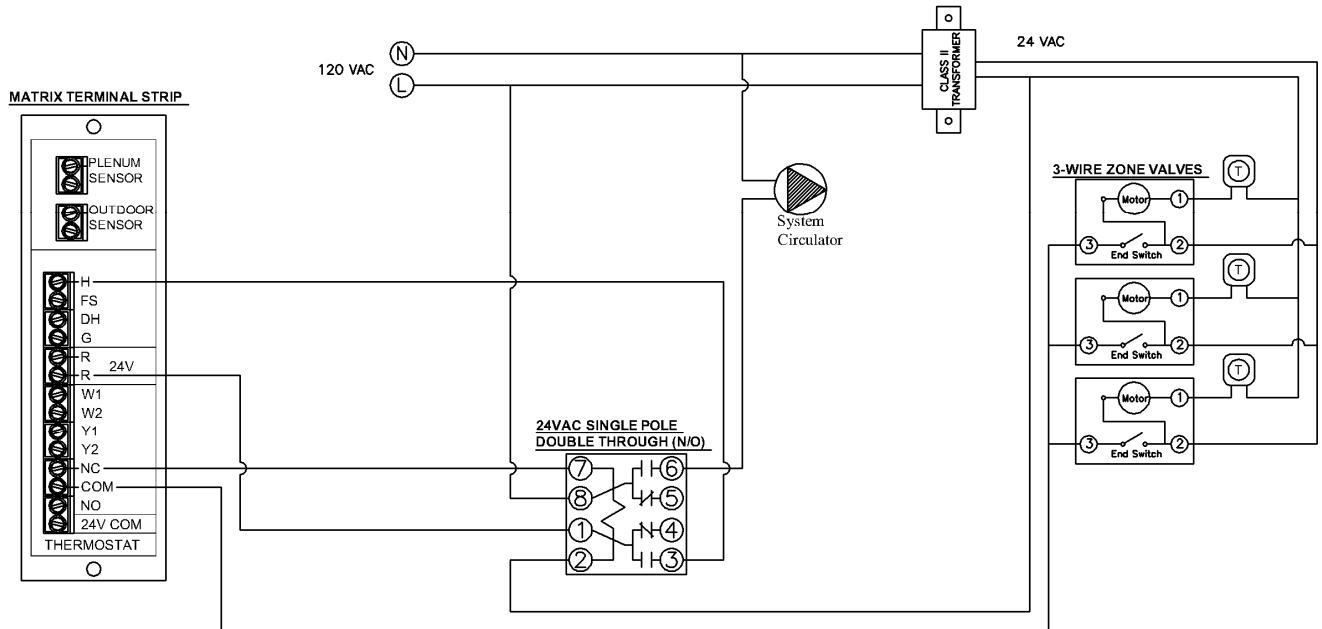

6.3.2(A) Multiple High Temperature Zones (Zone Circulators)

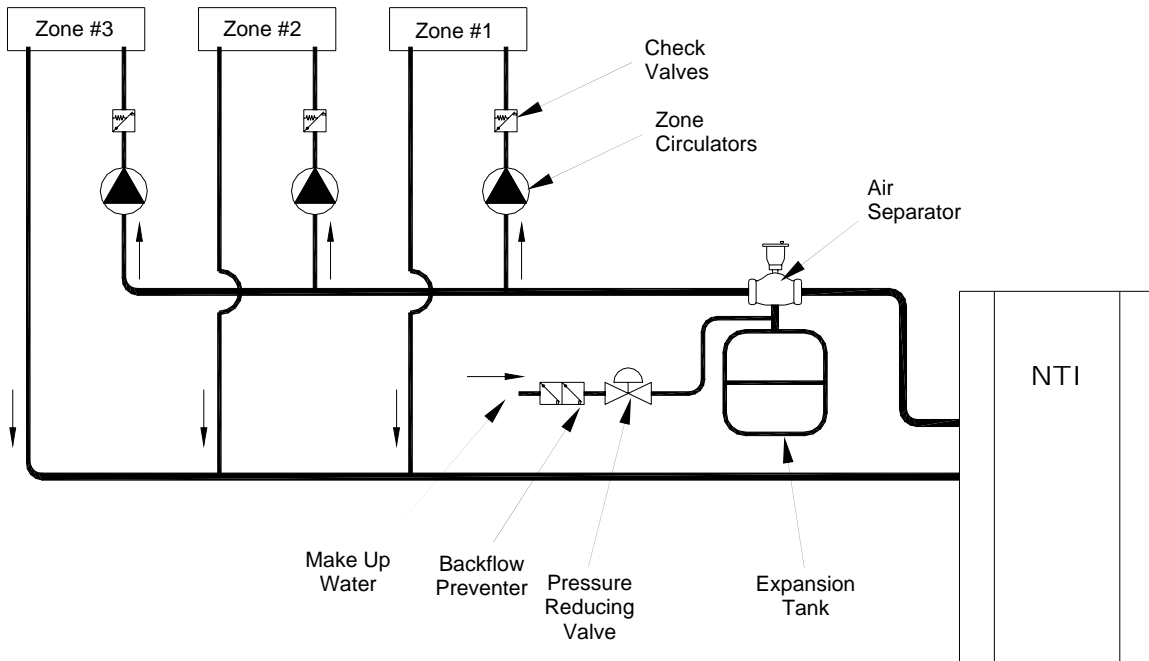

6.3.2(B) Multiple High Temperature Zones (Zone Circulators) – Wiring w/ Zone Controller

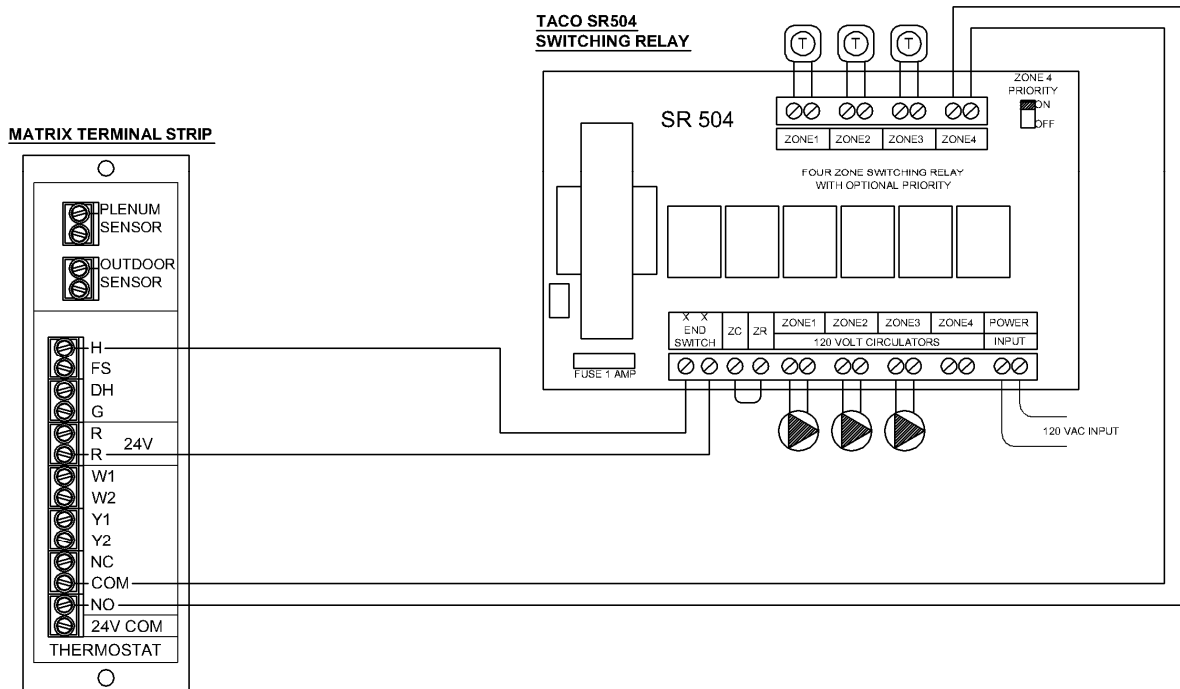

6.3.3 Multiple Controlled-Temperature Zones (Tempering Valves)

- Use wiring configuration in 6.3.2(B)

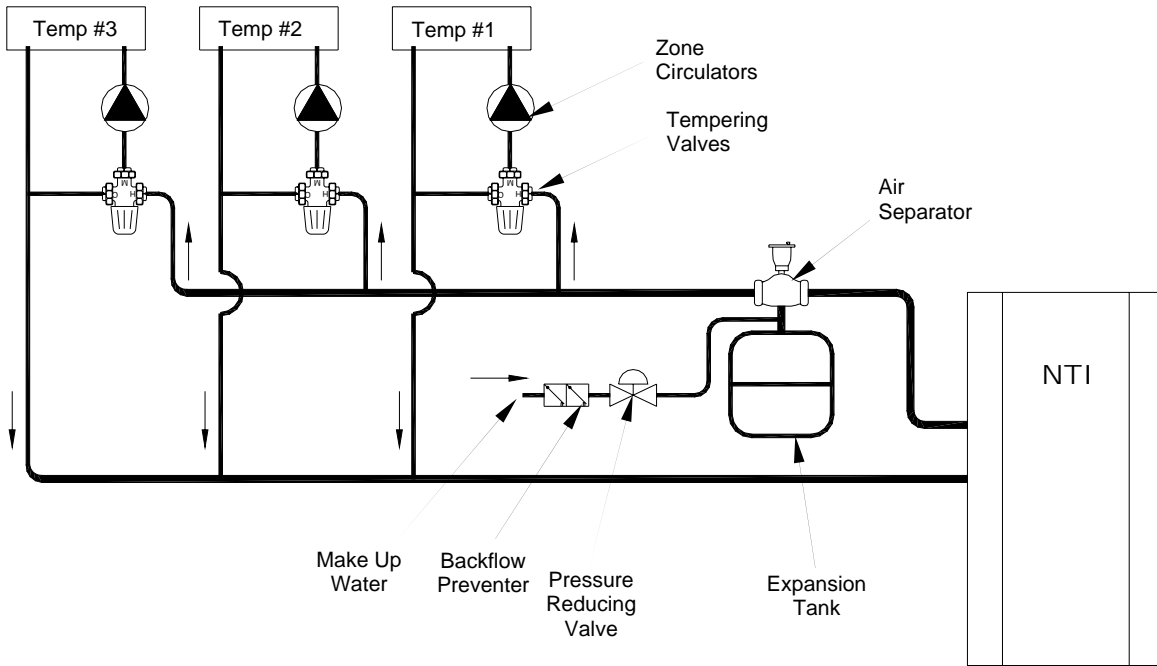

6.3.4(A) Single Controlled-Temperature Zones (Injection System)

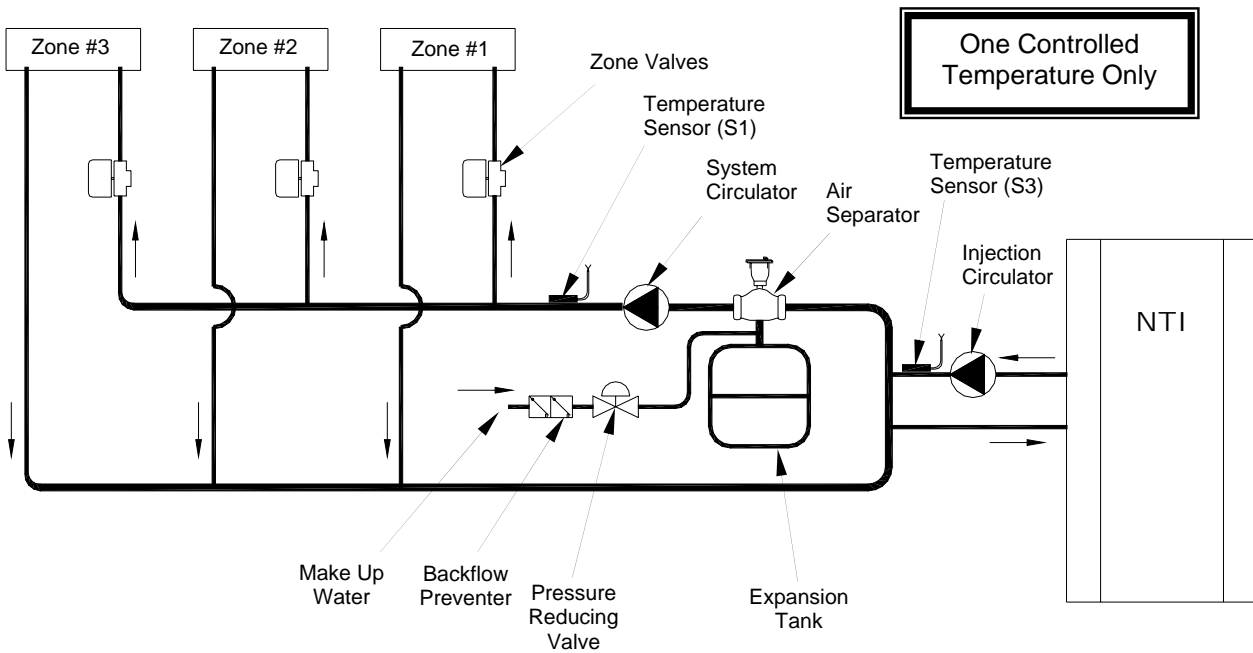

6.3.4(B) Single Controlled-Temperature Zones (Injection System) – Wiring Tekmar 356

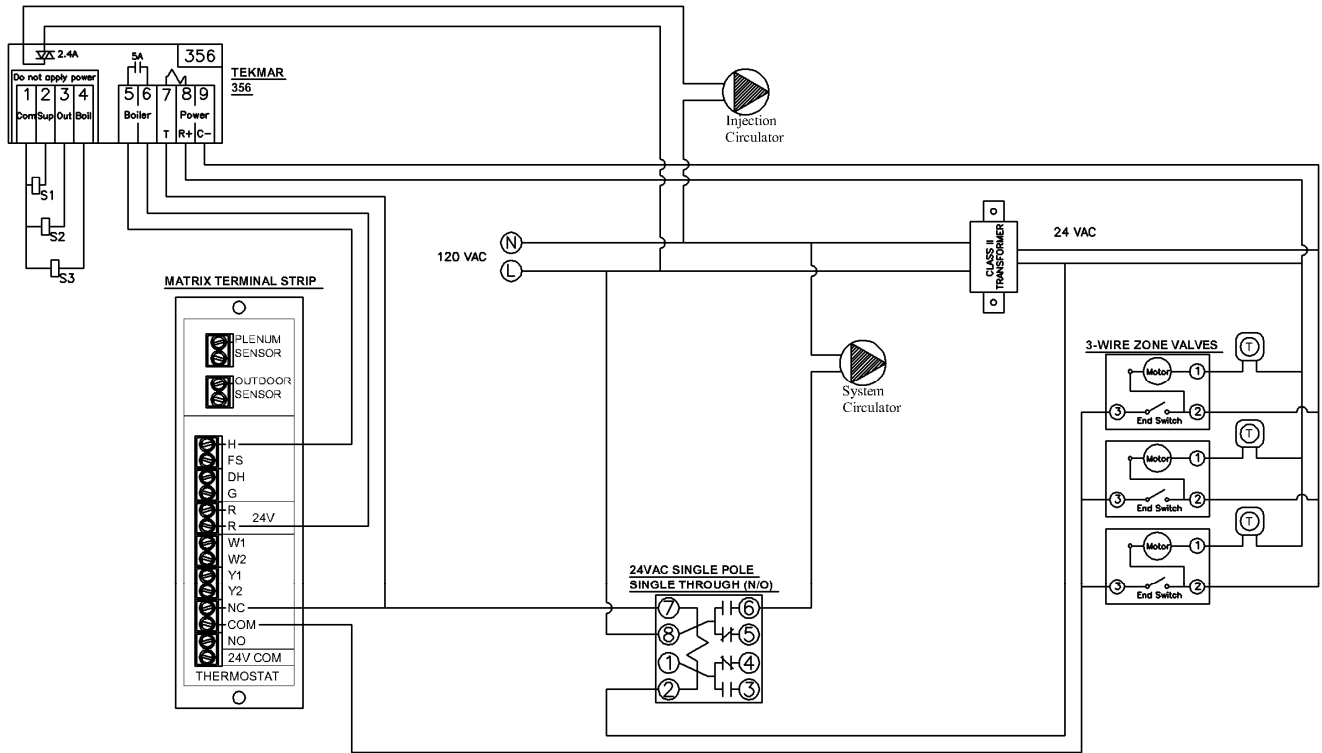

6.3.5 Multiple Controlled-Temperature Zones (Injection System)

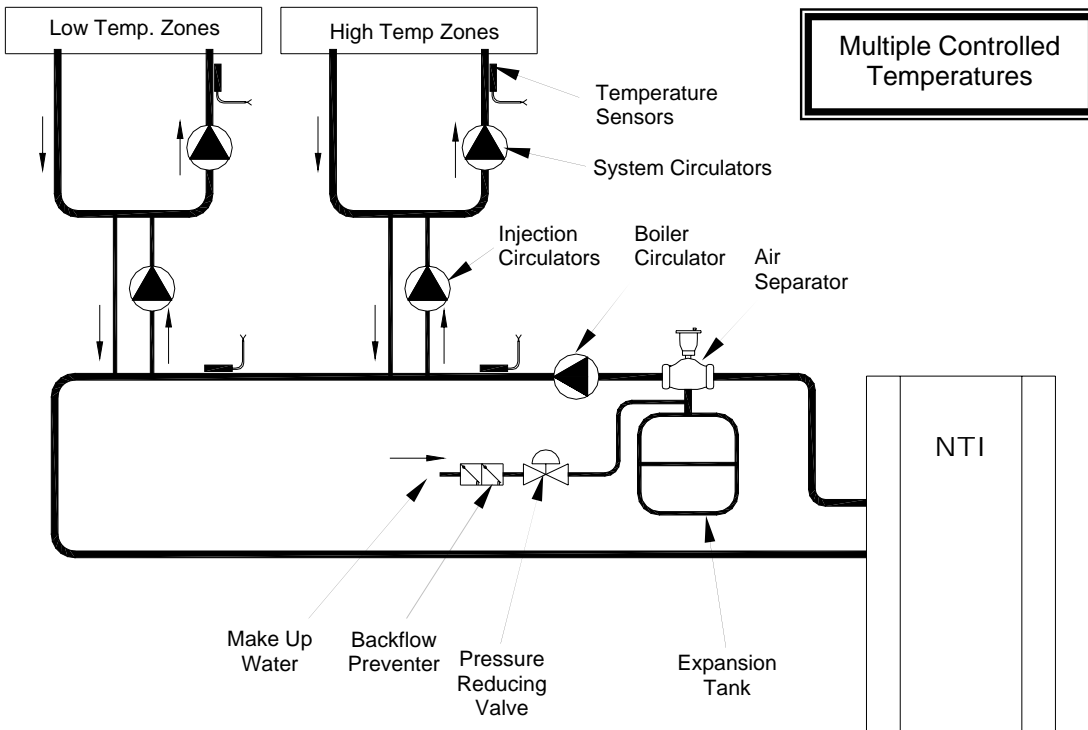

7.0 Domestic Hot Water System

7.1 DHW Description of Operation

The Matrix heats domestic hot water on demand, indirectly, using a brazed plate heat exchanger. Using an internal flow meter, the Matrix recognizes a DHW demand when the DHW flow rate is greater than 0.4gpm. The Matrix immediately goes into domestic mode, regardless of what other systems may have been operating, the burner fires and the Matrix attempts to achieve a calculated set point which depends on the sensed water flow rate and the programmed H2O setting (See Section 9.2.1). The H2O setting is accessed via the menu in the Matrix Fan (blue) controller, and should be set at a value equal to (or slightly greater) than the temperature required at the hot water fixtures, e.g. 125°F. The Fan control will communicate to the Boiler (red) controller a boiler water temperature set point applicable for the sensed flow rate and the H2O setting selected. The higher the flow rate and/or H2O setting, the higher the boiler water set point (boiler water setting will not exceed the H2O setting by more than 30°F). NTI provides a Thermostatic Mixing Valve adjustable from 100 to 145°F; the mixing valve shall be installed between the Matrix DHW supply fitting and the hot water supply pipe to the fixtures (See Figures 7.1 and 7.2), thus providing user protection from scalding hot water. Note: code requirements may require the maximum setting to be fixed at 120°F, see “Thermostatic Mixing Valve” below and the instructions included with the valve.

7.2 DHW System Plumbing & Set-up

DHW Inlet & Outlet Connections: The Matrix has two potable water connections, Inlet & Outlet, which exit the left side of the Matrix Cabinet; on the inside of the cabinet the two lines are connected to the Brazed Plate Heat Exchanger. The cold Inlet line flows through an integrated brass flow meter before connecting to the rear fitting of the Brazed Plate Heat Exchanger. The hot Outlet line flows directly from the front fitting of the Brazed Plate Heat Exchanger. See Figures 7.1 and 7.2 for installation details

Thermostatic Mixing Valve: A Sparcomix AM101-US-1 is provided with your package. This valve regulates the water temperature leaving the plate heat exchanger, and must be used in every instance. The dial can be set to the desired temperature required. Consult the Honeywell manual *SD/IS150* for detailed instructions and settings. (*Note: the valve must be set to a supply temperature of not more than 120°F. It is the responsibility of the installer to set the valve and remove the dial.*)



WARNING

IF THE ANTI-SCALD VALVE IS NOT INSTALLED TO THE HONEYWELL SHEET ‘SD/IS150’, AND THIS MANUAL, OPERATION MAY SUPPLY SCALDING HOT WATER TO THE OCCUPANTS.

Y-Strainer (Supplied): To protect the Matrix’s internal flow meter, it is important to install the factory supplied Y-Strainer in the location shown in Figures 7.1 and 7.2; dirt and other debris can cause the flow meter to malfunction.

Check Valve: A check valve must be field provided and installed on the outlet of the mixing valve to prevent expansion devices down stream from back flowing when the water pressure drops during cold water draws. Failure to prevent the backflow will cause water to flow forward through the flow switch, activating it, when the cold-water draw has ended and the water pressure increases.

Throttling Valve: Installed a throttling valve, after the mixing valve, to regulate the maximum hot water flow rate. The Matrix is limited to a firing rate of 150MBH; therefore excessive flow rates will result in cooler hot water temperatures.

Drain and Isolation Valves: Install drain and isolation valves on the inlet and outlet of the brazed plate heat exchanger, as shown in Figures 7.1 and 7.2 so it can be flushed free of possible build-up caused by dirt or hard water.

Hard Water: To prevent the formation of scale on the inside of the brazed plate heat exchanger and other components in the domestic hot water system, water with hardness higher than 50 ppm Calcium Carbonate must be treated with a “Water Softener” prior to entering the appliance. Plugging of the domestic system by scaling or accumulation of dirt is not the responsibility of NY Thermal Inc., and suitable steps shall be taken to avoid it.

Cleaning: Brazed plate heat exchangers operate with high turbulence flow, even at low flow rates. This high turbulence keeps small particles in suspension minimizing fouling and scaling. However, in some applications the fouling tendency can be very high, e.g. when using extremely hard water at high temperatures. In such cases it is always possible to clean the exchanger by circulating a cleaning liquid. Use a tank with weak acid, 5% phosphoric acid or, if the exchanger is frequently cleaned, 5% oxalic acid. Pump the cleaning liquid through the exchanger. For optimum cleaning, the cleaning solution flow rate should be a minimum of 1.5 times the normal flow rate, preferably in a back-flush mode. After use, do not forget to rinse the heat exchanger carefully with clean water. A solution of 1-2% sodium hydroxide (NaOH) or sodium bicarbonate (NaHCO₃) before the last rinse ensures that all acid is neutralized. Clean at regular intervals.

7.2.1 Instantaneous DHW (w/o Storage Tank)

The Matrix will provide domestic hot water continuously when flow is sensed by the flow meter. This method is the most efficient means of heating water by allowing the boiler to operate at a lower return water temperature, thus increasing combustion efficiency, and by minimizing standby losses. See Figure 7.1 for installation details.

DHW Limitations: As the Matrix produces domestic hot water instantaneously; there are inherent limitations of the system:

- NO STORAGE - As there is no water storage, the boiler can only provide water at the temperature specified at the corresponding flow rates. Flow through the fixtures must be regulated so not to exceed the ability of the boiler to heat the water. *MORE FLOW = LESS TEMPERATURE*. See Table 7.1 and “Procedure for Setting up Domestic Hot Water”.
- DOESN'T MAINTAIN TEMPERATURE – When there is no call for domestic the unit is off. From a dead stop the unit will detect flow and start providing heat in 15 seconds, and be up to capacity by 25 seconds. Once running, the unit can provide an endless amount of hot water. If the flow is momentarily turned off for whatever reason, the unit will turn off. Once off, the unit must relight, and not provide heat for 45-75 seconds. This will cause cold unheated water to pass through the unit, and advance through the domestic plumbing between the previously heated (hot) water, and the new (hot) water. *This can be mistaken for an inability to adequately heat the water.*

“Storage”Feature (St0): For improved domestic hot water comfort, the Matrix incorporates a “Storage” feature. This storage feature, when enabled, will keep the boiler water hot for a period of 1 to 24 hours following a call for domestic hot water (See Section 9.2.1 for setting). When the boiler water drops below 140°F the boiler will fire and bring the boiler to 180°F before shutting off. This “Storage” feature helps in reducing the wait time associated with a tankless hot water system. In systems where a storage tank is used (See Figure 7.2), this feature should be disabled, e.g. set to OFF.

Procedure for Setting up Domestic Hot Water: If the Matrix is being installed in an application that uses municipal water, often the pressure is high enough to generate flow rates at the faucets that will exceed the appliances capacity to heat it. See the following table to determine what flow can be expected at various inlet and outlet water temperatures.

Table 7.1 Matrix DHW Flow Rates (flow rates in usgpm)

		Inlet Water Temperature (deg. F)						
		40	45	50	55	60	65	70
Outlet Water (F)	110	3.9	4.2	4.5	4.9	5.4	6.0	6.7
	115	3.6	3.9	4.2	4.5	4.9	5.4	6.0
	120	3.4	3.6	3.9	4.2	4.5	4.9	5.4
	125	3.2	3.4	3.6	3.9	4.2	4.5	4.9
	130	3.0	3.2	3.4	3.6	3.9	4.2	4.5
	135	2.8	3.0	3.2	3.4	3.6	3.9	4.2
	140	2.7	2.8	3.0	3.2	3.4	3.6	3.9

To avoid having too much flow at the faucets use the throttling valve located at the “Cold Supply” in Figure 7.1 to limit the overall flow of domestic hot water. Follow these instructions to achieve the best delivery of DHW:

- Open throttle valve fully.
- Turn the dial on the mixing valve to the desired setting (do not exceed 120°F).
- Create the maximum amount of DHW flow that is likely to occur on a regular basis. (Usually tub faucet, or choose two other faucets)
- Allow the boiler to reach steady state, and then throttle the shut-off valve until the hot water exiting the plate heat exchanger is slightly warmer than the mixed water exiting the mixing valve. Ensure the boiler is firing at the maximum rate, if not increase the H20 setting and repeat this step. (It is beneficial to keep the H20 setting as low as possible to limit short cycling and maintain efficiency)

If the flow rates listed in Table 7.1 are not high enough for the application, install a storage tank with re-circulating loop as per Section 7.2.2 and Figure 7.2.

7.2.2 Matrix w/ DHW Storage Tank

To completely avoid the DHW limitations inherent with on demand hot water heating, install a DHW storage tank as per the DHW plumbing schematic shown in Figure 7.2. When the tank temperature is insufficient, an aqua-stat (T-stat) located within the storage tank completes a 120VAC circuit to a potable (bronze or Stainless Steel) circulating pump. The pump circulates water from the bottom of the storage tank (typical location of a drain fitting) to the DHW inlet fitting of the Matrix (Rear fitting to the Flow Meter and Brazed Plate Heat Exchanger). The Matrix Flow Meter senses the water flow and triggers a DHW demand; heated water flows from the Matrix and enters the inlet fitting of the storage tank.

Figure 7.1 DHW Piping (Tankless – On demand)

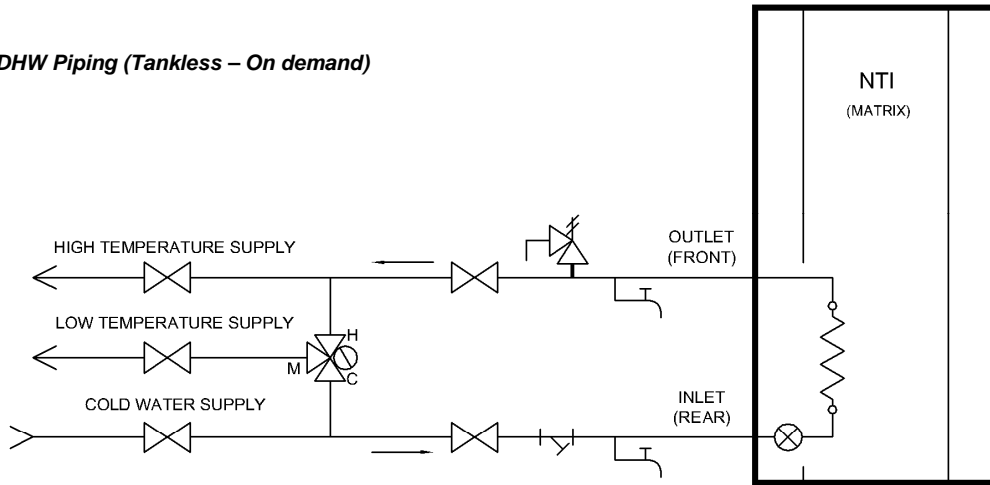
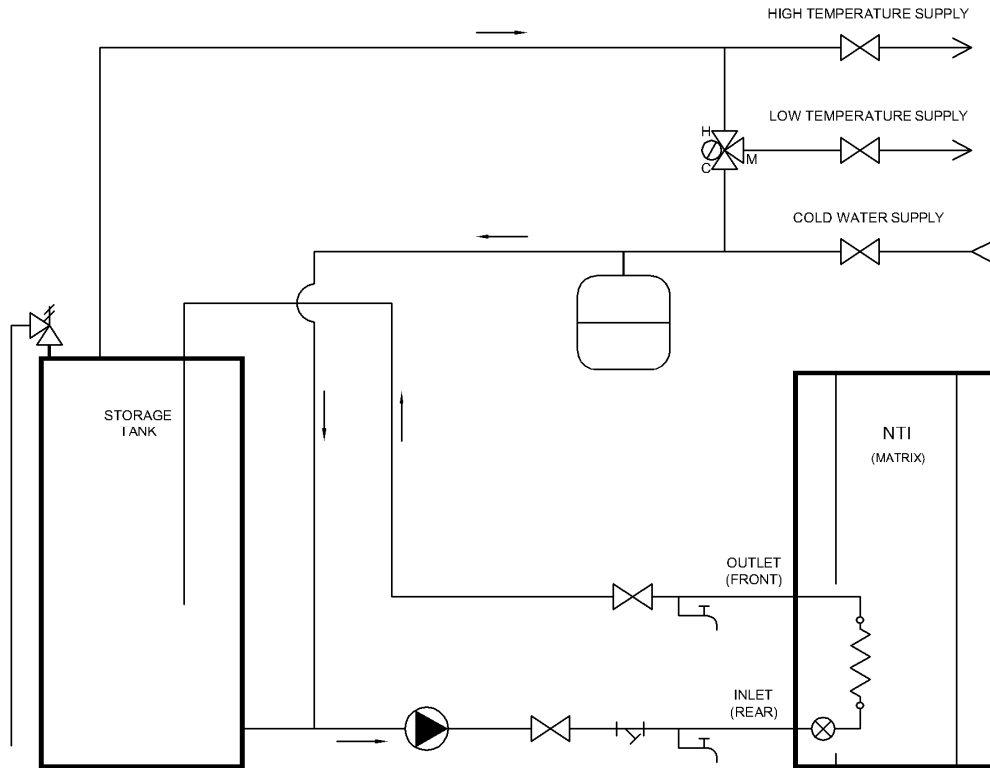

Figure 7.2 DHW Piping (w/ Storage Tank)



LEGEND

SYMBOL	DESCRIPTION	SYMBOL	DESCRIPTION	SYMBOL	DESCRIPTION
	ISOLATION / THROTTLE VALVE		BRONZE PUMP		FLOW METER
	DRAIN VALVE		THERMOSTATIC MIXING VALVE		Y STRAINER
	EXPANSION TANK		TEMPERATURE AND PRESSURE RELIEF VALVE		BRAZED PLATE HEAT EXCHANGER

8.0 WIRING

8.1 Field Wiring to Matrix

All wiring must be in accordance with the Canadian Electrical code, CSA C22.2, and any applicable local codes. Ensure that the wiring is in accordance with this manual.

The boiler must be electrically grounded in accordance with the National Electrical Code ANSI/NFPA 70, or local codes, and/or the Canadian Electrical Code CSA C22.1.

All connections to the Matrix are made at the terminal board provided. This terminal board can be found on the left side of the appliance just above the plumbing connections. The following connections are available, and provide different functions according to which inputs are energized.

Figure 8.1 Line Voltage Field Wiring

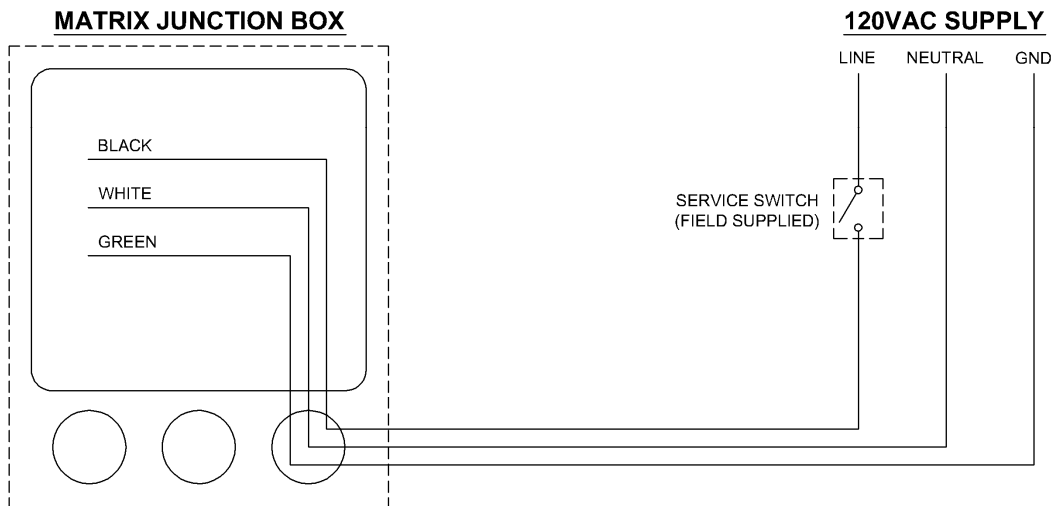

WARNING

THE MATRIX TERMINAL STRIP IS FOR LOW VOLTAGE (MAX 24 VAC) AND LOW LOAD (MAX 1 AMP) CONNECTIONS. ANY ELECTRICAL LOADS IN EXCESS OF 24VAC OR 1 AMP MUST BE ISOLATED USING RELAYS. FAILURE TO FOLLOW THESE INSTRUCTION CAN RESULT IN FIRE.

ATTENTION

1. Before providing 120 Volts to the appliance, do a continuity check between all wires and ground to make sure that there are no electrical leaks that could damage the Matrix circuitry.
2. Before providing 120 Volts to the appliance, do a polarity check of the line and neutral wires, line must be connected to black and neutral must be connected to white.
3. Do not use magnetic tip screwdriver near the Matrix control boards.
4. Ensure that the wiring for the plenum and outdoor air sensor is not damaged or grounded.
5. Caution: Label all wires prior to disconnecting them when servicing controls. Wiring errors can cause improper and dangerous operation

Figure 8.2 Low Voltage Filed Wiring

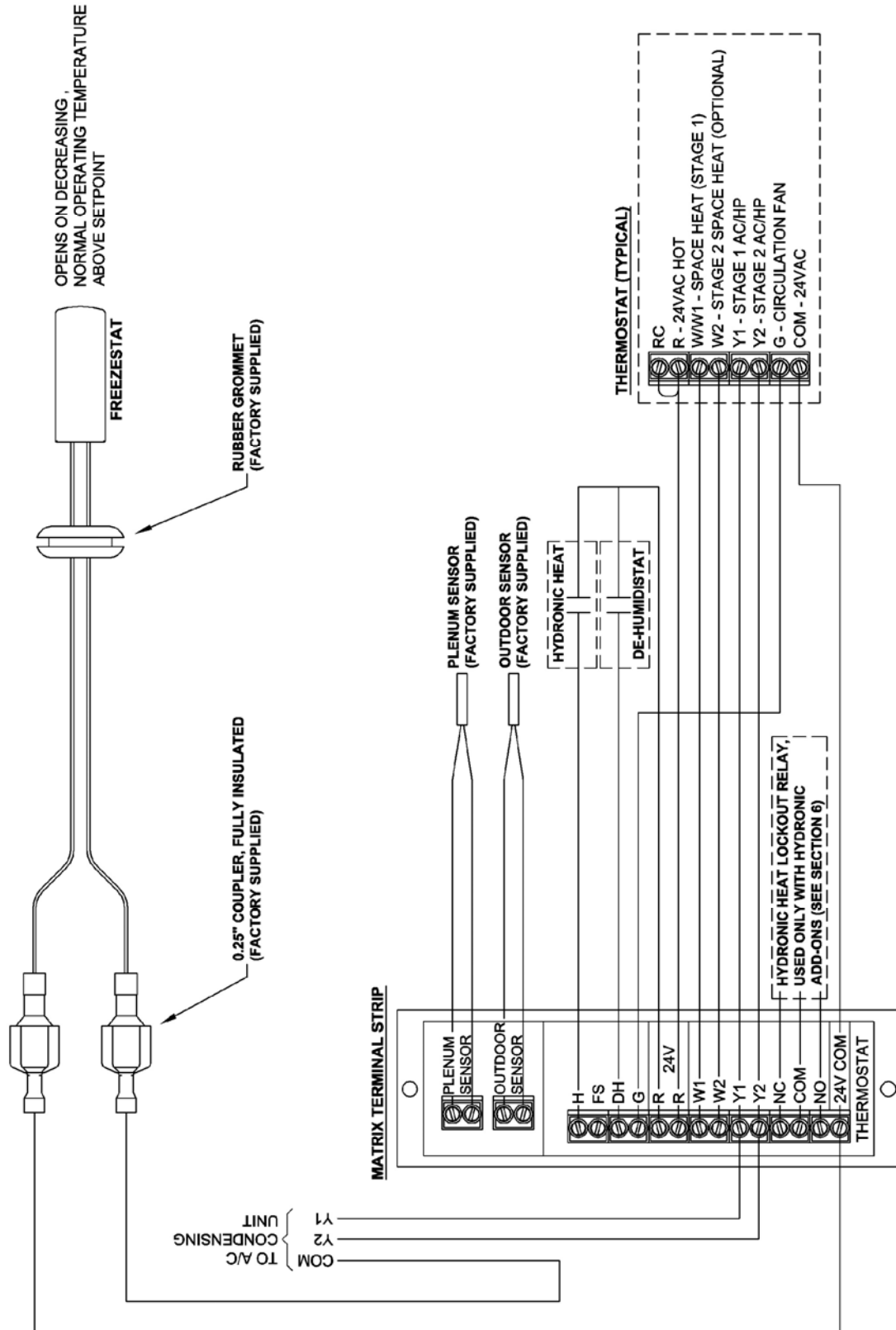

Table 8.1 Low Voltage Field Connections (See Figure 8.2)

Terminal	Description
Plenum Sensor	Plenum Temperature Sensor – Each Matrix is provided with a temperature sensor that is to be field installed in the supply plenum. When installed the Matrix Fan (blue) controller with display the plenum temperature and may provide additional features depending on the application.
Outdoor Sensor	Outdoor Temperature Sensor – Each Matrix is provided with an outdoor temperature sensor that may be field installed to provide Outdoor Reset for applications where the Matrix is providing heat to a Hydronic Heating System.
H	Hydronic Heat Input – Input requiring 24VAC from terminal R to initiate a demand for Hydronic Heat. Switch is made using an isolated end switch (dry contact), e.g. hydronic zone controller. Not used in applications w/o Hydronic Heating. Boiler temperature setting is made via the HYD setting in the (red) Boiler Controller, see Table 9.4.
FS	DHW Heat Input – Input requiring 24VAC from terminal R to initiate a demand for DHW Heat. Switch is made using an isolated end switch (dry contact), e.g. dhw flow switch or tank aqua-stat. Note: this input is normally not used, as the Matrix incorporates a DHW Flow Meter to detect DHW demands.
DH	De-Humidistat Input – Input requiring 24VAC from terminal R to initiate a demand for high ventilation with the optional built-in HRV (Heat Recovery Ventilator). Switch is made using an isolated end switch (dry contact), e.g. centrally located De-humidistat (may be incorporated in Thermostat), or “wet room” timers. Note: this function only acts to de-humidify during colder weather by increasing ventilation, it is not intended for de-humidification during warmer months.
G	Circulation Fan Input – Input requiring 24VAC from terminal R to initiate a demand for the Circulation Fan. Switch is made using an isolated end switch (dry contact) normally incorporated in the home thermostat. Air circulation rate is set via the FAN setting in the (blue) Fan Controller, see Table 9.5.
R	24VAC Hot – Power supply for inputs H, FS, DH, W1, W2, Y1 and Y2.
W1	Forced Air Central Heat Input – Input requiring 24VAC from terminal R to initiate a demand for the Forced Air Central Heat. Switch is made using an isolated end switch (dry contact) normally incorporated in the home thermostat.
W2	Forced Air Central Heat Input (Stage 2) - Input requiring 24VAC from terminal R to initiate a demand for Stage 2 Forced Air Central Heat. Switch is made using an isolated end switch (dry contact) normally incorporated in the home thermostat. Note: most application will not require the use of input W2, NTI recommends using W1 only for Forced Air Central Heating.
Y1	Air-Conditioning / Heat Pump Input (Stage 1) – Input requiring 24VAC from terminal R to initiate a demand for stage 1 cooling (or heat pump). Switch is made using an isolated end switch (dry contact) normally incorporated in the home thermostat. CFM rate adjustable via Y1 setting in the (blue) Fan Controller, see Table 9.5.
Y2	Air-Conditioning / Heat Pump Input (Stage 2) – Input requiring 24VAC from terminal R to initiate a demand for stage 2 cooling (or heat pump). Switch is made using an isolated end switch (dry contact) normally incorporated in the home thermostat. CFM rate adjustable via Y2 setting in the (blue) Fan Controller, see Table 9.5. Note: Y2 demand overrides a Y1 demand.
NC	Hydronic Heat Lockout Relay Contacts – The Matrix Fan control incorporates a Normally Closed (NC) and a Normally Open (NO) relay contact that switches position on a demand for DHW. The contacts are to be used to lockout the Hydronic Heat draw during concurrent DHW demands in order to maintain DHW priority. Maximum switching capacity of 2 Amps at 24VAC.
COM	
NO	
24V COM	24VAC Common – Neutral for the 24VAC power supply from the Matrix. This contact can be used in conjunction with terminal R to provide a power source for a digital thermostat. NOTICE: 24V COM to the A/C Condenser Unit must be broken by the Matrix AC Freeze-stat included with the installation package, see Figure 8.2.

8.2 Matrix Factory Wiring Schematic

8.2.1 Boiler Control Wiring

Consult diagram on unit for exact wire routing.

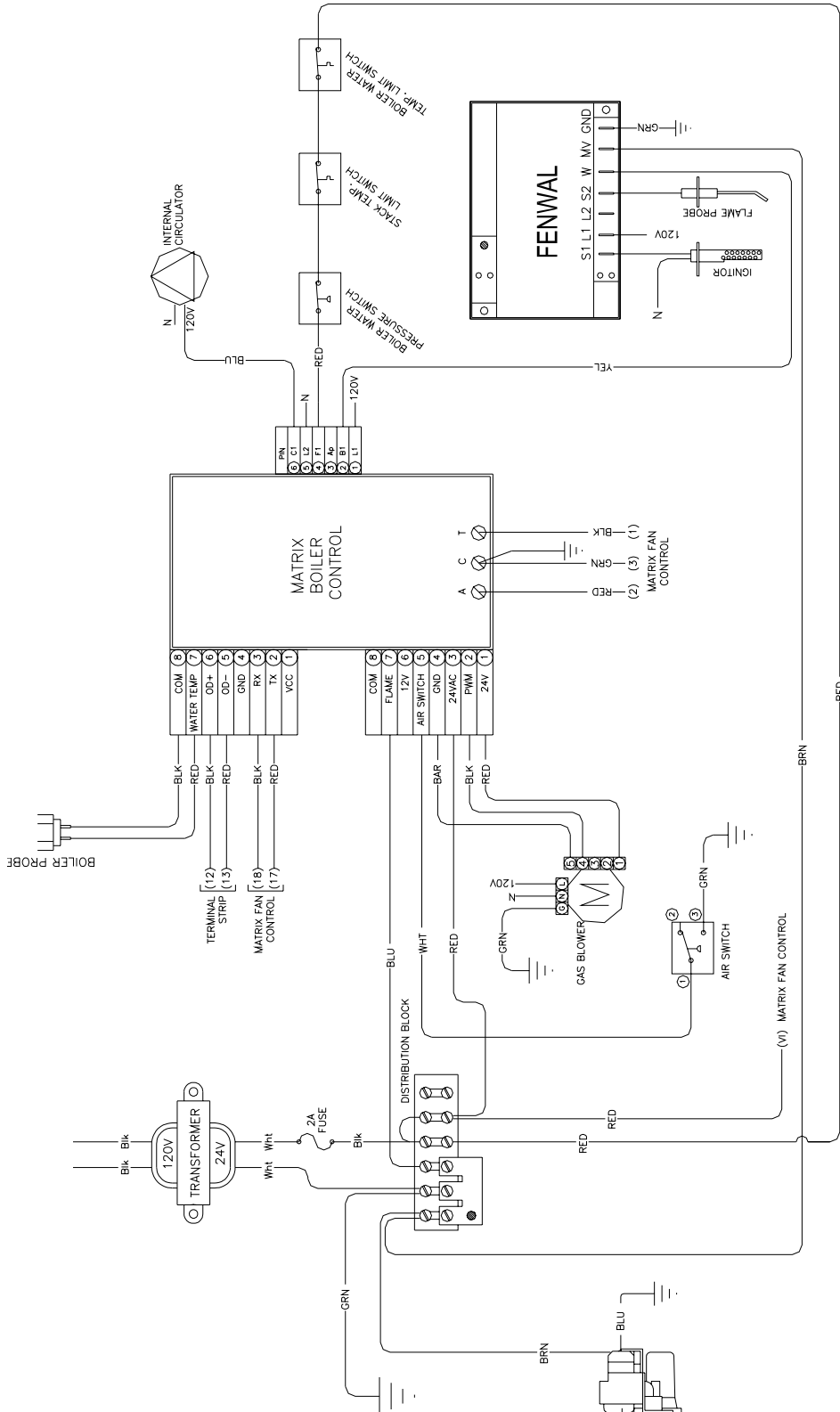

8.2.2 Fan Control Wiring

Consult diagram on unit for exact wire routing.

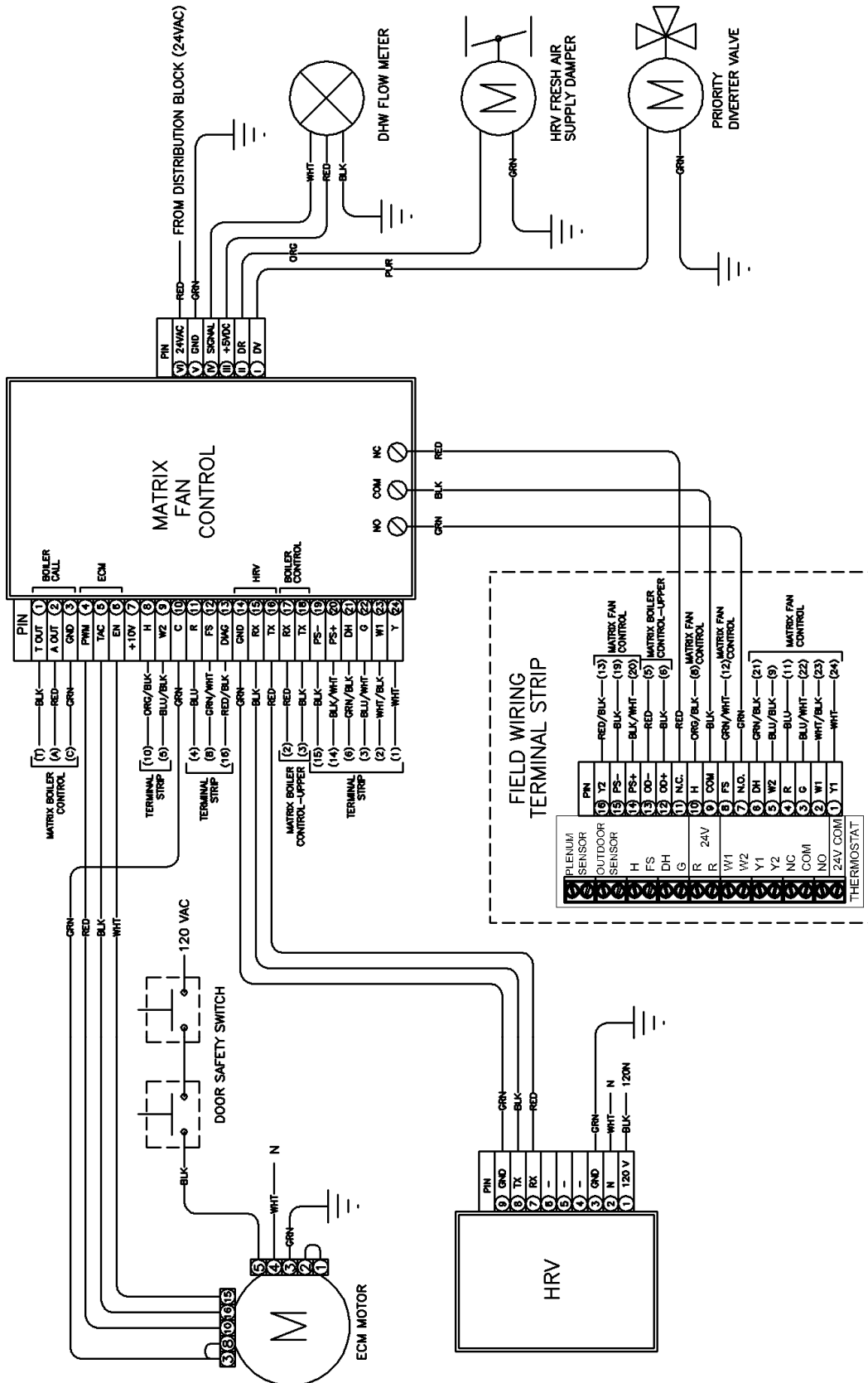

9.0 CONTROL SETUP

The Matrix used two devices to control the functions required by the Matrix. The Matrix Boiler Control (red face) controls and ensures the safe operation of the boiler functions of the Matrix much the same as the Sentry 2100 does in the Trinity products. The Matrix Fan Control (blue face) controls all of the operation and safety functions related to air handling and hot water dispatching. The fan controller controls the forced air modulation, ventilation, as well as priority of domestic hot water and secondary heating systems.

ATTENTION

The Matrix Boiler Control (Sentry) is different from the Sentry controller used on any other NTI products and is NOT INTERCHANGEABLE.

9.1 Controller Displays

9.1.1 Matrix Boiler Control (Sentry) Display (Red Face Plate)

The Matrix Boiler Control communicates to the user what is happening in the system by using an LED display and a series of LED indicators.

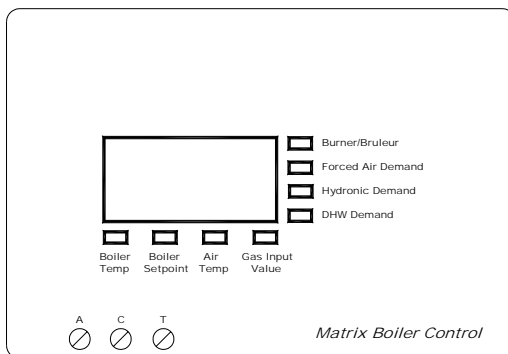

Table 9.1 Matrix Boiler Control Display

Display	Description
Burner/Brûleur	Indicates that the ignition system is activated
Forced Air Demand	Indicates a call for forced air heat – Please note. There may still be a call for forced air heat even when thermostat is satisfied (off).
Hydronic Demand	Indicates a call for hydronic heat
DHW Demand	Indicates a call for domestic hot water
Boiler Temp	When illuminated, display is showing boiler water temperature
Boiler Setpoint	When illuminated, display is showing boiler water set point
Air Temp	When illuminated, display is showing outdoor temperature
Gas Input Value	When illuminated, display is showing current gas input value . See chart to determine input rate.

9.1.2 Matrix Fan Control Display (Blue Face Plate)

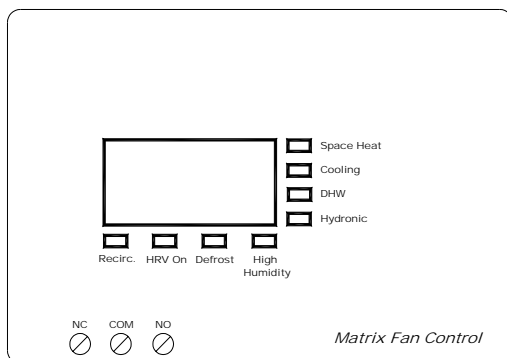

Table 9.2 Matrix Fan Control Display

Display	Description
Space Heat	Indicates a call for forced air heating
Cooling	Indicates a call for cooling
DHW	Indicates a call for domestic hot water
Hydronic	Indicates a call for hydronic heat
ReCirc.	Indicates a call for continuous circulation/ventilation
HRV On	Indicates the HRV is ventilating
Defrost	Indicates the HRV is in defrost mode
High Humidity	Indicates a call for high ventilation of HRV

9.2 Operation and Set-up

The Matrix employs a pneumatic modulation system. This modulation system increases or decreases the velocity of the combustion blower, to meet the demand for heating. The gas valve senses this change in blower pressure and introduces the required amount of gas to ensure correct combustion. The Sentry reads the boiler water temperature, compares it to the set point, and adjusts the burner firing rate accordingly by varying the speed of the combustion blower.

The (Blue) Fan Controller communicates the appropriate demand and temperature set point to the (Red) Boiler Controller via a series of digital and analog inputs. Table 9.3 shows the Boiler Controller’s response to the demand. For more information on ‘RESET MODE’ see section ‘9.3 Outdoor Sensor Operation’.

Table 9.3 Conventional vs. Outdoor Reset Mode

CONVENTIONAL MODE		Standby/Storage Mode		Primary Forced Air Call (W1)	Auxiliary Forced Air Call (W2)	Shared Call Forced Air/Hydronic	Hydronic Demand (H)	DHW Demand
	Condition	Storage Off	Storage On	Heat (W1)	Aux Heat (W2)	Shared (W1/W2 and H)	Hydronic Call	Domestic Only
	Set Point	-	160°F	SP ^{Note 1}	HI ^{Note 1}	Greater of SP/ HI and HYD	HYD	H2O to H2O+30
	Burner On	-	140°F	SP ^{Note 1}	HI ^{Note 1}	Greater of SP/ HI and HYD	HYD-DIF	H2O+30
	Burner Off	-	180°F	210°F	210°F	210°F	HYD + 10	210°F
	Heat Circ.	Off	On	On	On	On	On	On

RESET MODE		Standby/Storage Mode		Primary Forced Air Call (W1)	Auxiliary Forced Air Call (W2)	Shared Call Forced Air/Hydronic	Hydronic Demand (H)	DHW Demand
	Condition	Storage Off	Storage On	Heat (W1)	Aux Heat (W2)	Shared (W1/W2 and H)	Hydronic Call	Domestic Only
	Set Point	-	160°F	SP ^{Note 1}	HI ^{Calc. Note 1}	Greater of SP/ HI ^{Calc.} and HYD ^{Calc.}	HYD ^{Calc.}	H2O to H2O+30
	Burner On	-	140°F	SP ^{Note 1}	HI ^{Calc. Note 1}	Greater of SP/ HI ^{Calc.} and HYD ^{Calc.}	HYD ^{Calc.} -DIF	H2O+30
	Burner Off	-	180°F	210°F	210°F	210°F	HYD ^{Calc.} + 10	210°F
	Heat Circ.	Off	On	On	On	On	On	On

Note 1. SP (Setpoint) received from Matrix Fan Controller.

9.2.1 Setting Matrix Boiler Control (Sentry)

Programming is accomplished by a series of three push buttons located on the bottom side of the control. (*Function*, \uparrow and \downarrow). To enter the programming mode, press the function key once. To scroll through the various menu options depress \uparrow until the menu is displayed. To alter the value press *Function* once, and the current value will be displayed, then use \uparrow for up, and \downarrow for down, until the desired value is obtained. To enter the selected value press *Function*, which will return to the menu. When all desired values are selected, scroll to the RUN menu, and press *Function*, which exits the Programming Mode and initiates normal operation. A safety feature has been added to ensure that if the control is left in the Program Mode, the unit will turn off if left in program mode longer than 30 seconds without receiving an input. Press *Function* once to continue programming or to start boiler operation.

Table 9.4 Matrix Boiler Control Programming

Menu Level		Description	
Main	Value		Typical Settings
RUN		Program Mode - When Run is displayed controller is in 'Prog' mode. Arrow up or down to scroll through menus	
HYD	80-200	Hydronic Call Setpoint	100-120 Infloor (High Mass) 140-160 Infloor (Low Mass) 140-160 Fan Coil
HI	80-200	Auxiliary Heat Setpoint – prior to outdoor reset adjustment	190
DIF	1-40	Differential Setting - Applies only to Hydronic Only setpoint. Temperature difference below setpoint at which burner will re-light.	10
RES	70-HI	Sets Outdoor Reset Curve Slope – See Determining Reset Temperature for more information.	85
SFS	75-100	Starting Gas Input Value	80
HFS	100-240	Maximum Gas Input Value	240
LFS	46-100	Minimum Gas Input Value	48 (min 46)
FrE	ON/OFF	Freeze Protection – Operates burner and circulator if temperature drops below 40°F.	ON
Sto	OFF-24	Storage Feature Timer – Length of time in hours storage feature will keep boiler hot.	2

To start the control operation, you must return to RUN on the menu, and press Function. Normal operation will begin. Controller will return to RUN mode if no button is pressed for 2 minutes.

9.2.2 Setting Matrix Fan Control

Just as the Matrix Boiler Controller controls all of the operation and safety functions of the boiler, the Matrix Fan Controller, controls all of the operation and safety functions related to air handling and hot water dispatching. The fan controller controls the forced air modulation, ventilation, as well as priority of domestic hot water and secondary heating systems.

Table 9.5 Matrix Fan Control Programming

Menu Level				Description
Main	Sub	Value	Default	
RUN				When Run is displayed, controller is in 'Prog' mode. Arrow up or down to scroll through menus
HRV		OFF	ON	HRV Mode – Always off unless call for high ventilation (DH)
		ON		HRV Mode – Continuous Ventilation. HRV will exchange air at low ventilation rate during a call for forced air heat (W1 or W2) or continuous circulation (G). Will increase to high ventilation rate with a high ventilation call (24vac @ DH)
HEA		PF1	PF1	Heat Profile 1 400 to 1000CFM; 50,000 Btu/h max.
		PF2		Heat Profile 2 400 to 1100CFM; 77,000 Btu/h max.
		PF3		Heat Profile 3 400 to 1200CFM; 105,000 Btu/h max.
Y1		40-Y2	80	Stage 1 AC/HP Flow x 10 = CFM, settable from 400 up to Y2 (1600 max).
Y2		Y1-160	120	Stage 2 AC/HP Flow x 10 = CFM, settable from Y1 (400 min) up to 1600.
FAN		40-160	40	Fan circulation rate (G) x 10 = CFM, settable from 400 to 1600.
BAL	SCL	30-100	60	HRV Balancing – (see HRV section for more details)
	ECL	30-100	60	
	SCH	30-100	60	
	ECH	30-100	60	
	SOL	30-100	100	
	EOL	30-100	100	
	SOH	30-100	100	
	EOH	30-100	100	
H2O		100-160	125	Set point for desired DHW temperature in degrees Fahrenheit.
rAd		1 or 2	2	Determines the anticipated supply plenum size. For units with the 20x16" Supply Plenum, set to 1. For units with the 22.5x18.5" Supply Plenum, set to 2.

To start the control operation, you must return to RUN on the menu, and press Function. Normal operation will begin. Controller will return to RUN mode if no button is pressed for 2 minutes.

9.3 Outdoor Sensor Operation

The outdoor sensor is connected to the terminal board on the left side of the matrix. The two terminals are labeled ‘OUTDOOR SENSOR’.

When the Outdoor sensor is not used, or the outdoor temperature is below 0°F, the Matrix operates at a boiler water temperature equal to the HYD or HI setpoint during a call for Hydronic or Emergency Heat respectively. When the sensor is used and the outdoor temperature is above 0°F, the Matrix boiler control automatically reduces the operating temperature of the boiler during those calls. Using the following formula, the control factors in the current outdoor temperature, control setpoint (HYD or HI), and the RES (reset) setpoint, in determining the appropriate operating water temperature.

Figure 9.2 Outdoor Reset Calculation

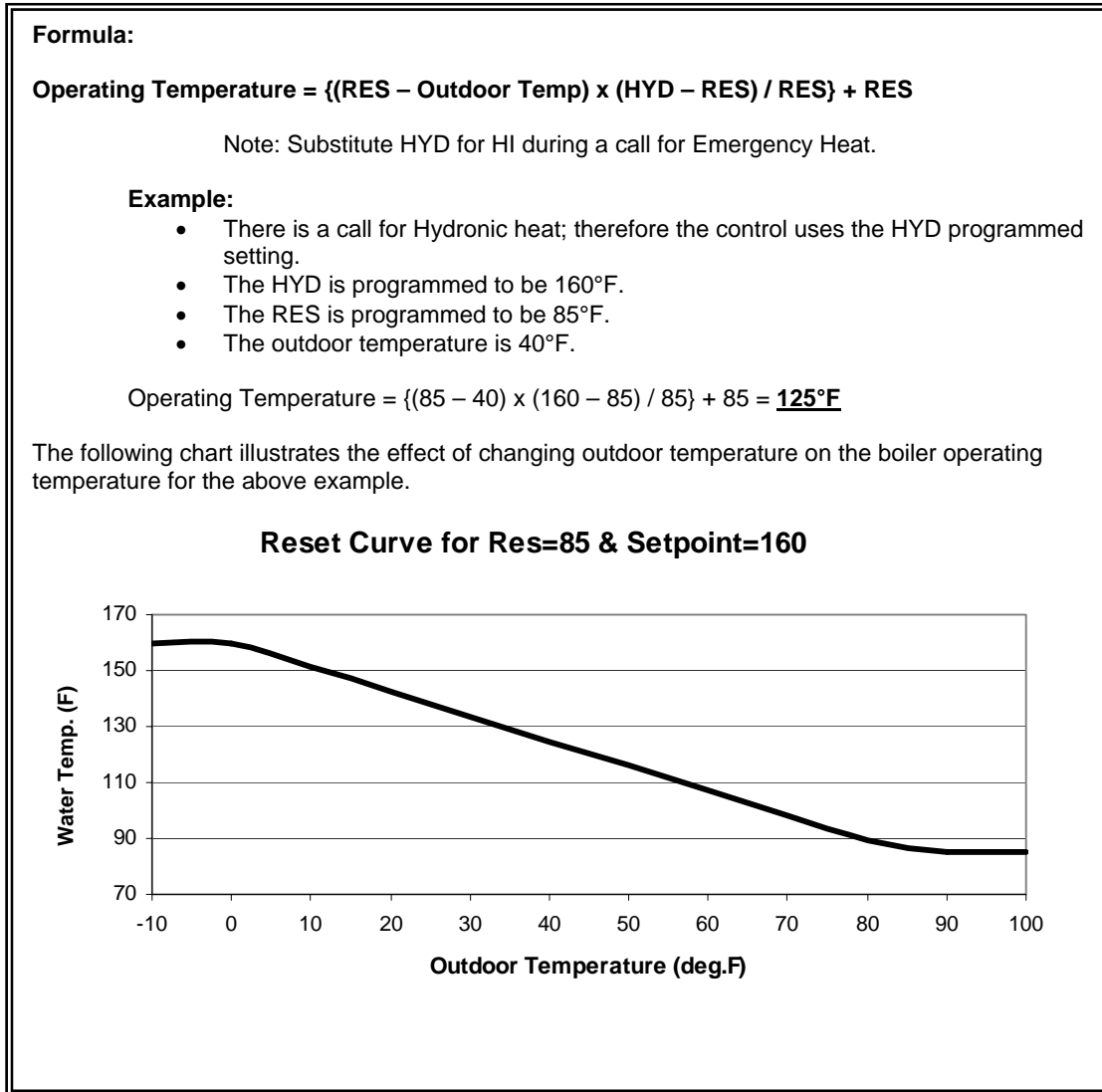

10.0 MATRIX BLOWER OPERATION

10.1 Forced Air Heating

The Matrix forced-air heating module is a step-modulated system, which provides varying heat output rates by adjusting air flow and water temperature through a fan coil.

Table 10.1 Fancoil Output Chart

Heating Stage	Heat Profile 1 (PF1)				Heat Profile 2 (PF2)				Heat Profile 3 (PF3)			
	CFM	Set Point (°F)	Air Temp (°F)	Btu/Hr Out	CFM	Set Point (°F)	Air Temp (°F)	Btu/Hr Out	CFM	Set Point (°F)	Air Temp (°F)	Btu/Hr Out
1	400	108	104	14000	400	108	104	14000	400	108	104	14000
2	550	110	104	19000	550	110	104	19000	550	110	104	19000
3	670	113	105	24000	670	113	105	24000	670	113	105	24000
4	720	117	108	27700	730	122	112	31500	750	128	116	35500
5	760	120	110	31400	790	131	118	39100	820	141	125	47100
6	810	124	112	35100	850	138	122	46700	900	152	132	58700
7	860	127	114	38800	910	145	127	54200	975	163	139	70200
8	900	130	115	42500	970	152	131	61800	1050	172	144	81800
9	950	133	117	46300	1030	158	134	69400	1120	181	149	93400
10	1000	136	118	50000	1100	164	137	77000	1200	190	153	105000

Actual Output rates may vary from what is shown

Example. At stage 4 (Profile 1) the Matrix provides 720 CFM across the fan coil, which is receiving 117°F water from the boiler. The coil then supplies plenum air at 108° F or ~27700 BTU/hr.

On an initial thermostat call (24VAC @ W1), space heating begins by providing heat at Stage 3 (~24,000 BTU/hr) (if hydronic heat is also calling (24VAC @ H) heating will begin at stage 1) and so long as the thermostat is not satisfied, incrementally increases to a maximum of Stage 10 (maximum output). When the thermostat becomes satisfied, an average of the heat output rate during the call is calculated. The boiler remains lit and the space heat output begins an incremental decrease in heat output rate beginning with the stage just below the calculated average and ending with either the thermostat re-calling or if the thermostat never re-calls, the output rate decreases to minimum stage after which the boiler shuts off.

If the thermostat re-calls prior to the minimum heat stage, a new calculated average of the thermostat off cycle is calculated and the boiler again begins an increasing ramp, only this time it begins at the calculated stage and not necessarily at the minimum stage.

This computation “hunts” for the heat loss of the dwelling based on the reaction of the thermostat to the rise and fall of the space temperature and the heat cycle rate of the thermostat.

If at any time the plenum temperature exceeds 160°F, the boiler will stop supplying heat until the temperature in the supply plenum drops below 140°F, during which time an AL2 error message will be displayed.

ATTENTION

The burner will remain on and the Matrix will provide heat when the thermostat is off. This is normal and is required to provide constant efficient heat.

Call for Heat (24VAC @ W1): Normal Thermostat call, Matrix operates as a step-modulating furnace as described above. If HRV set to ‘ON’, HRV will operate at the low (continuous) ventilation rate.

Call for Auxiliary Heat (24 VAC @ W2): When calling, furnace will provide heat at a stage 10 output rate. With a call for auxiliary heating the Matrix will function as a single stage, full fire appliance. This means the burner will come on with a thermostat call and go off when the call is satisfied. If HRV set to ‘ON’, HRV will operate at the low (continuous) ventilation rate.

Outdoor Sensor: The auxiliary heating function (24VAC @ W2) will utilize the outdoor sensor if available. The outdoor reset function is not used for W1 heating. This function is also active during a hydronic heat demand (24VAC @ H).

Plenum Sensor: The Matrix is equipped with a plenum temperature sensor that must be field installed in the supply plenum and wired to the furnaces external terminal strip. When installed the Matrix fan control displays the plenum temperature and will use it to detect problems in the supply of heat to the space.

Call for Circulating Fan (24VAC @ G): Matrix operates at the programmed air circulation rate according to the “FAN” setting in the Fan (blue) controller (400-1600 CFM). If HRV is set to ‘ON’ (See 8.2 Fan Controller), the HRV will ventilate at the low (Continuous) ventilation rate.

Call for Dehumidification (24VAC @ DH): Matrix operates at the minimum air circulation rate (400 CFM). HRV will ventilate at the high (Override) ventilation rate.

Call for Cooling Fan (24VAC @ Y1): Matrix operates at the prescribed air circulation rate (Y1x10 CFM – See 8.2 Fan Control). HRV will not operate during a call for cooling unless there is a concurrent call for DH – Dehumidification or G – Continuous and HRV is set to ON.

Call for Cooling Fan (24VAC @ Y2): Matrix operates at the prescribed air circulation rate (Y2x10 CFM – See 8.2 Fan Control). HRV will not operate during a call for cooling unless there is a concurrent call for DH – Dehumidification or G – Continuous and HRV is set to ON.

10.2 Duct Sizing

When sizing ductwork, a maximum flow velocity of 800 fpm is desired. Table 11 shows common duct sizes at specified flows. The maximum flows that can be expected are shown in Table 10.3. It is important to maintain the return plenum pressure as low as possible. Keeping this ductwork as free flowing as possible will offer more supply static pressure to overcome A/C coils, closed registers etc while maintaining constant flow.

Any additional filtration, humidification, or de-humidification equipment should be installed external to the return or supply ducts so not to create additional restriction.

Table 10.2 Duct Size vs. Air Flow

Airflow (CFM)	Area (sqft)	Duct Sizing (inches)				
1600	2	24x12	20x16			
1200	1.5	24x10	20x12	18x12		
1000	1.25		20x10	18x10	16x12	
800	1			18x8	16x10	12x12

Based on 800 fpm max airflow velocity

Table 10.3 Maximum Air Flow Rates

Fan Control Setting		ESPmax*	CFM
Heating (HEA)	Cooling (COO)		
	160 max	.35 inwg	1600
	160 max	.6 inwg	1500
	160 max	.75 inwg	1400
	120 (3 Ton)		1200
	80 (2 Ton)		800
PF3	No Cooling	<1 inwg	1200
PF2	No Cooling	<1 inwg	1100
PF1	No Cooling	<1 inwg	1000

Example #1 No cooling function with Heating profile of PF2 selected. Maximum airflow will be 1100 CFM.

Example #2 Cooling set to 800 CFM for 2 tons of cooling with Heating profile of PF3 selected. Maximum airflow will be greater of cooling or heating function. Maximum 1200 CFM.

**Measured from return plenum to supply plenum prior to A/C coil. ECM motor can produce near constant flow provided horsepower or maximum speed of motor is not exceeded.*

11.0 HEAT RECOVERY VENTILATION

11.1 Ventilation Needs

With the evolution toward more energy efficient, tighter homes, air quality problems have increased. With less natural ventilation pollutants such as pet dander, humidity, tobacco smoke and wood ash now become trapped inside the home. Mechanical ventilation is the process of exhausting the polluted air from the space and replacing it with fresh air from outside. The amount of ventilation required varies from home to home and can be estimated using one of the following methods:

11.1.1 Room Count Calculation

Living Space	Number of Rooms	CFM (L/S)	CFM Req'd
Master Bedroom		x 20 cfm (10 L/s) =	
With Basement		x 20 cfm (10 L/s) =	
Without Basement			
Single Bedroom		x 10 cfm (5 L/s) =	
Living Room		x 10 cfm (5 L/s) =	
Dining Room		x 10 cfm (5 L/s) =	
Family Room		x 10 cfm (5 L/s) =	
Recreational Room		x 10 cfm (5 L/s) =	
Other			
Kitchen		x 10 cfm (5 L/s) =	
Bathroom		x 10 cfm (5 L/s) =	
Laundry Room		x 10 cfm (5 L/s) =	
Utility Room		x 10 cfm (5 L/s) =	
Total Ventilation Requirement (sum last column)			=

11.1.2 Air Change per Hour Method

Total cu.ft x 0.3 / 60 = Total Ventilation Required

Example. A 25' x 40' house with basement
 1000 sqft x 8' high x 2(main floor and basement) = 16,000 cu.ft
 16,000 x .3 air changes per hour = 4,800 cu.ft/hr
 4,800 cu.ft/hr / 60 = 80 cfm
80 cfm is ventilation requirement

11.2 Types of Installation

There are two basic methods of installing the ventilator in the Matrix:

Exhaust at the source. Stale air is drawn from the kitchen and bathrooms.

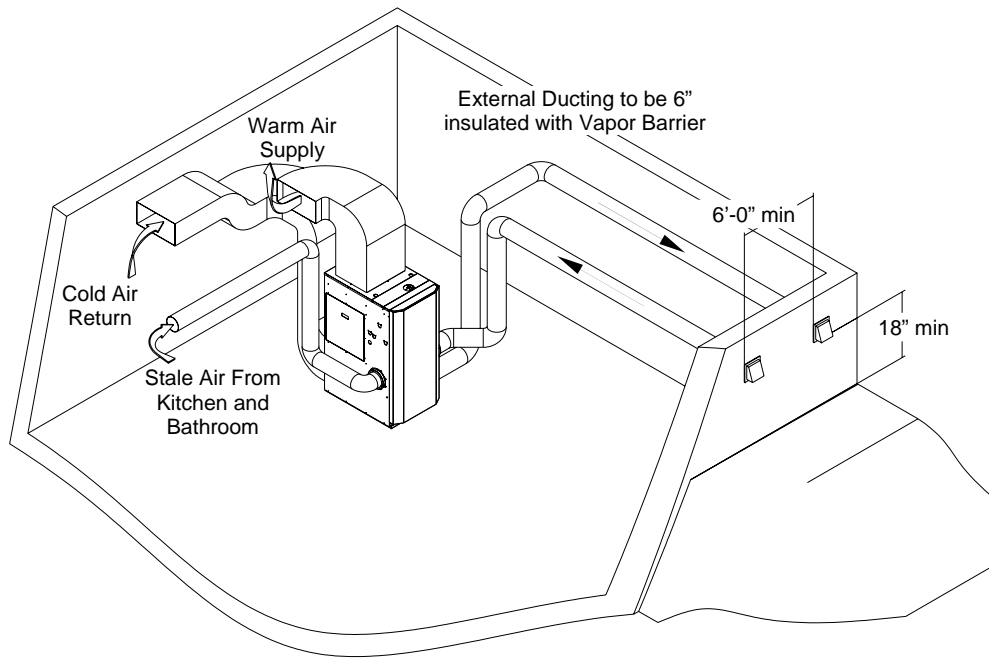

Exhaust from the return (Simplified System). Stale air is drawn from the return plenum.

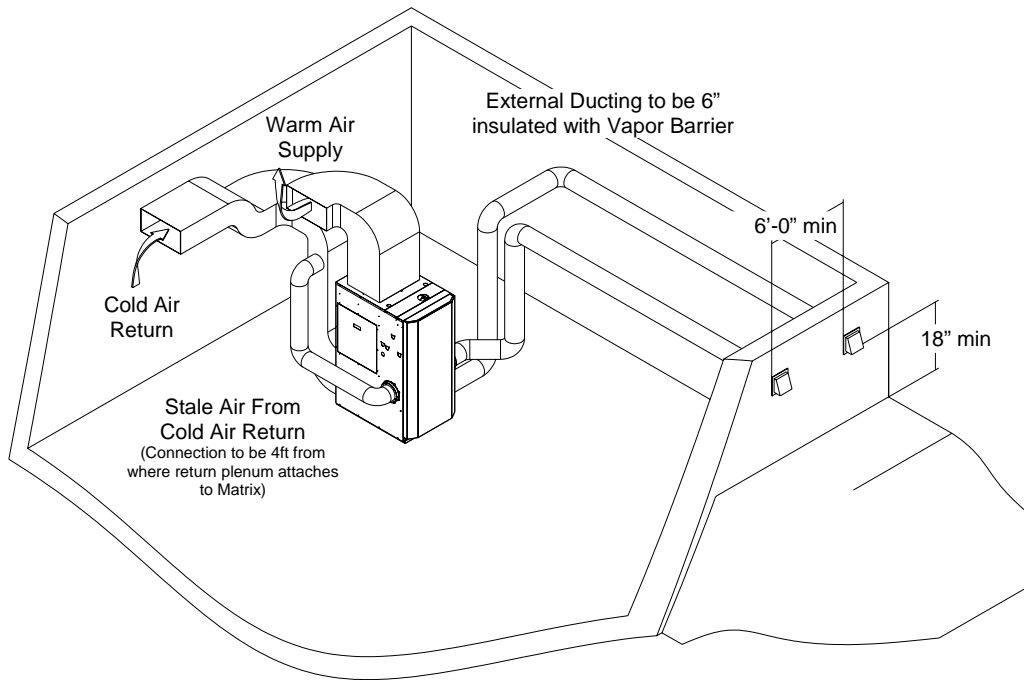

IMPORTANT

When using the Simplified System method, exhaust connection to the return must be 4' from where the return connects to the Matrix.

IMPORTANT

All main HRV ductwork to be 6" round.
Exterior connections are to be insulated and include a vapor barrier.

11.3 Damper Box

Included in the installation kit is a damper box. This damper box eliminates the infiltration of cold outside air when the HRV is off or in defrost mode. It is to be installed with the actuator on the top side and screw to the Matrix using the four screws provided.

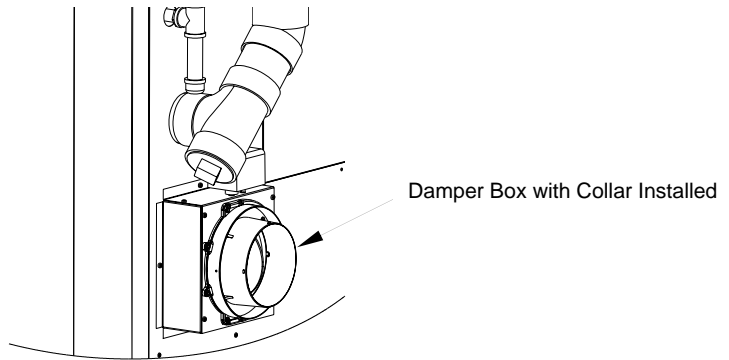

11.4 Condensate Drain

Condensation from defrost will collect in the ventilator and drain from the sloped drain pan. This condensation must be evacuated from the unit. The condensate tubing provided must be routed through the hole in the side of the appliance and attached to the 90° elbow directly underneath the ventilation module. From there the condensate tube must be emptied into a suitable floor drain or if necessary the emptying drain must have a trap to prevent the infiltration of toxic gases.

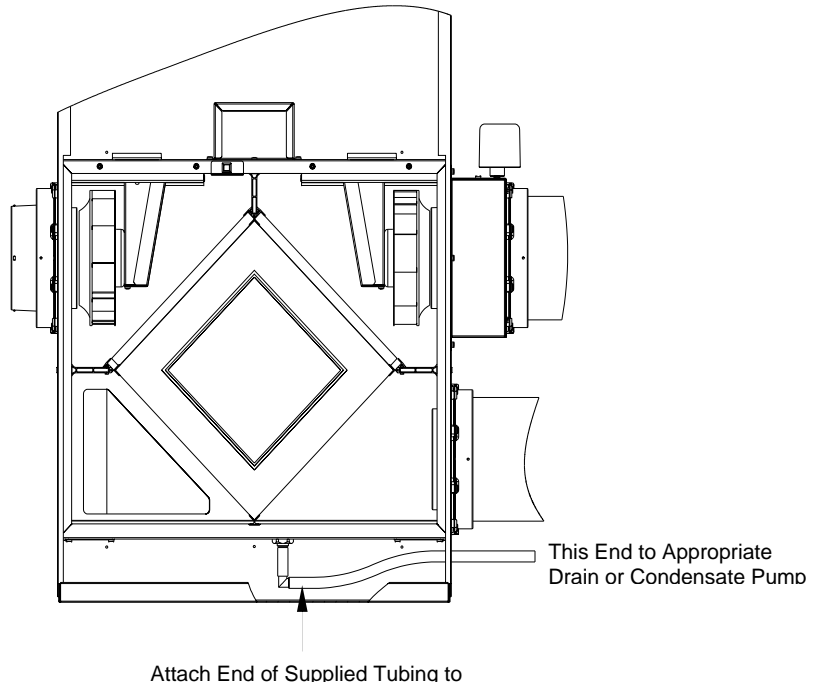

11.5 HRV Balancing

The HRV must be balance properly in order to operate at maximum efficiency and avoid problems.

The balancing process ensures the volume of fresh air from outside is equal to the amount of stale air being expelled from the home over all air handler conditions. A variation of 10% is acceptable with the greater volume being stale air drawn from the home.

The Matrix uses motor speed to balance airflows. This method of balancing provides quieter operation and reduced energy consumption over the traditional balancing damper approach.

Flow is measured with the use of a Magnehelic (0-.25 inwg range) and an airflow grid, flow collar or “Flow Measuring Station”. NTI offers an airflow grid, PN: 83554, that is designed to be installed in a 1” hole located in a 6” duct. It is important that the flow grid be the same size as the ductwork, and be installed according to the manufacturers instructions. Typically a straight run of 18” on either side of the flow grid is adequate to avoid false readings. It is helpful if a flow grid is installed in each of the supply and exhaust ducts.

Procedure:

1. Attach the upflow port of the flow grid to the positive pressure port of the Magnehelic and the down flow port to the negative port.
2. Zero the Magnehelic.
3. Begin by selecting the heating profile required in the Matrix Fan Controller ‘HEA’ menu. Refer to the heating section of the manual for more explanation. The heating profile selected dictates the air handler blower speeds and is important to the proper functioning of the HRV. Every time the heating profile is changed the HRV will require re-balancing.
4. Once the heating profile is selected, advance to the ‘BAL’ menu. By pressing the ‘FUNCTION’ button you will enter the balancing mode of the HRV. Press the up arrow button and advance through the menus until you reach the ‘EOH’ menu item. By pressing the ‘FUNCTION’ button you will enter the ‘EOH’ menu. A number will appear. You will notice the HRV start, if it is not already running, and the main blower of the air handle will come up to speed. The number on the display represents the speed of the HRV fan in percentage. In the case of ‘EOH’ the number shown represents the speed of the exhaust ‘E’ fan during a call for high ventilation ‘O’ (override) while the air handler blower is running at the high ‘H’ heating speed. The maximum speed setting is 100%, the minimum 30%. Adjust the speed up or down until the desired flow rate is achieved. Table 11.1, on the following page, has been provided to help in explaining the different settings.
5. Complete the table adjusting each of the setting to the HRV Ventilation Rate provided. These rates are a guideline only and can be adjusted to meet the specific application.

-Note- When adjusting the exhaust speeds, the supply fan will increase to full speed.

When the balancing is complete, the HRV will maintain balance at any ventilation rate during any air handler blower condition. This is a unique feature of the Matrix and is essential in providing efficient and adequate ventilation in this integrated system.

ATTENTION

The HRV balance must be checked and if necessary rebalanced every time the Heating (HEA) setting is changed, or if there is change to the system which would significantly change the static pressure at the return plenum or the exterior ducts to the HRV.

Figure 11.1 Sample Balancing Setup

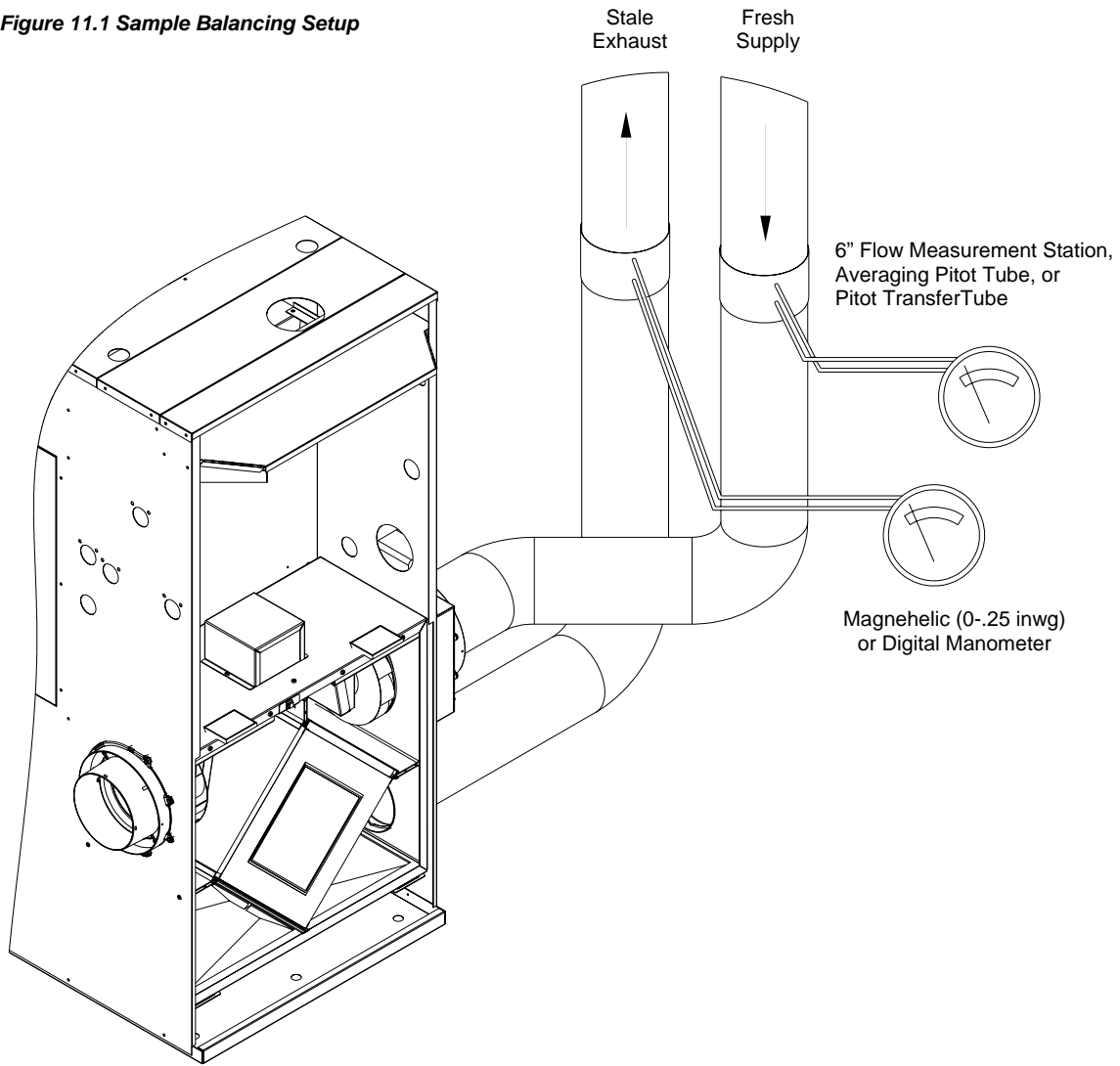

Table 11.1 HRV Balancing Table

Menu Item	Description	Sample HRV Ventilation Rates	Installed Ventilation Rates	Installed Fan Speed
EOH	HRV Exhaust at Override (high ventilation) rate, balanced during High air circulation rate (800/1000/1200CFM).	120cfm (55 L/s)		
SOH	HRV Supply at Override (high ventilation) rate, balanced during High air circulation rate (800/1000/1200CFM).	120cfm (55 L/s)		
EOL	HRV Exhaust at Override (high ventilation) rate, balanced during Low air circulation rate (300/400/500CFM).	120cfm (55 L/s)		
SOL	HRV Supply at Override (high ventilation) rate, balanced during Low air circulation rate (300/400/500CFM).	120cfm (55 L/s)		
ECH	HRV Exhaust at Continuous (low ventilation) rate, balanced during High air circulation rate (800/1000/1200CFM).	70cfm (30 L/s)		
SCH	HRV Supply at Continuous (low ventilation) rate, balanced during High air circulation rate (800/1000/1200CFM).	70cfm (30 L/s)		
ECL	HRV Exhaust at Continuous (low ventilation) rate, balanced during Low air circulation rate (300/400/500CFM).	70cfm (30 L/s)		
SCL	HRV Supply at Continuous (low ventilation) rate, balanced during Low air circulation rate (300/400/500CFM).	70cfm (30 L/s)		

12.0 LIGHTING BOILER



Before Start-up refer to **Mandatory Pre-commissioning Procedure for Plastic Venting** in Section 3.0. Failure to follow these instructions can result in explosions, injury or death.



Prior to turning the gas supply on and lighting the appliance, ensure all aspects of the installation are complete and in conformance with the instructions provided in this manual, including the Vent/Air-Intake, Condensate Drain, and System Water Piping. Failure to precisely follow these instructions will cause a fire or explosion resulting in property damage, serious injury or death.

Do not store or use gasoline or other flammable vapors & liquids in the vicinity of this or any other appliance. Failure to follow instructions could result in explosion causing property damage, serious injury or death.



If you do not follow these instructions exactly, a fire or explosion may result causing property damage, serious injury or death.



Should overheating occur or the gas supply fail to shut off, turn off the manual gas control valve to the appliance. Failure to follow instructions could result in explosion causing property damage, serious injury or death.

FOR YOUR SAFETY, READ BEFORE OPERATING

- A) This appliance does not have a pilot. It is equipped with an ignition device which automatically lights the burner. Do not try to light the burner by hand.
- B) BEFORE OPERATING smell all around the appliance area for gas. Be sure to smell next to the floor because some gas is heavier than air and will settle on the floor.
WHAT TO DO IF YOU SMELL GAS:
 - Do not try to light any appliance.
 - Do not touch any electric switch.
 - Do not use any phone in your building.
 - Immediately call your gas supplier from a neighbor's phone. Follow the gas supplier's instructions.
 - If you cannot reach your gas supplier, call the fire department.
- C) Use only your hand to push in or turn the gas control knob. Never use tools. If the knob will not push in or turn by hand, don't try to repair it, call a qualified service technician. Force or attempted repair may result in a fire or explosion.
- D) Do not use this appliance if any part has been under water. Immediately call a qualified service technician to inspect the appliance and to replace any part of the control system and any gas control which has been under water.

OPERATING INSTRUCTIONS

1. STOP! Read the safety information above very carefully.
2. Set the thermostat to lowest setting. Turn off all electric power to the appliance.
3. This appliance does not have a pilot. It is equipped with an ignition device which automatically lights the burner. Do not try to light the burner by hand.
4. Turn the manual gas valve to the OFF position. Remove front access panel.
5. Wait five (5) minutes to clear out any gas. Then smell for gas, including near the floor. If you smell gas, STOP! Follow "B" in the safety information above. If you don't smell gas, go to the next step.
6. Turn the manual gas valve ON. Wait an additional five (5) minutes smelling for gas.
7. Replace the front access panel.
8. Set thermostat to highest setting. Turn on all electric power to the appliance.
9. Ignition sequence is automatic. Combustion will occur after a brief fan purge.
10. If ignition does not occur, follow the instructions "To Turn Off Gas To Appliance" and call your service technician or gas supplier.

TO TURN OFF GAS TO THE APPLIANCE

1. STOP! Read the safety information above very carefully.
2. Turn off all electric power to the appliance
3. Turn the manual gas valve to the OFF position



WARNING

The initial lighting of the appliance must be performed by a licensed Gas Technician. Failure to follow instructions may result in property damage, serious injury or death.

- Ensure the appliance is wired in accordance with this manual.
- Ensure the gas shut-off valve is turned on, and that the gas system has been fully tested for leaks.
- Ensure the system is completely filled with water, and that ALL the air is purged out.



DANGER

Allow primers/cements to cure for 8 hours prior to Start-up. If curing time is less than 8 hours, first perform Steps 2 through 6 of **Mandatory Pre-commissioning Procedure for Plastic Venting** in Section 3.0. Failure to follow these instructions can result in explosion, serious injury or death.

Initial Start-Up

1. Turn on power to the Trinity Lx and turn-up the Thermostat(s). The appliance should run through a purge, and combustion should occur. (The control system has a built in ignition retry, allowing the system to try at least three times, before locking-out.)
2. With the unit operating at full capacity, verify that the gas line pressure is 4-10.5 inches w.c. for Natural gas, and 9-13 inches w.c. for Propane (See Section 5.0 for details).
3. Using an appropriate Oxygen or Carbon Dioxide analyzer, take a sample of the flue gas. The sample must fall within the acceptable ranges for Carbon Dioxide, which is 8.5% - 9.5% for Natural gas, and 9.5%-10.5% for propane (See Section 5.0 for details).
4. Perform at least three lights in succession to ensure proper operation.
5. After the three successive lights, unplug the flame probe, and allow the unit to cycle again. Ensure that it tries to light, and locks out on safety reset. Once you have successfully activated the flame safety system, replace the wire on the flame sensor, and reconfirm proper lighting.



WARNING

If the unit fails to light consistently and smoothly, contact NTI for assistance at 1-800-688-2575. Never allow the appliance to continue to operate if the ignition or operation of the burner is rough or erratic. Failure to follow these instructions could result in serious injury or death.

Re-lighting Unit

1. Stop and read these instructions very carefully.
2. Set the thermostat to the lowest setting, and then turn off all power to the appliance.
3. This appliance does not have a pilot. It is equipped with an ignition device that automatically lights the burner. Do not try to light the burner by hand.
4. Turn the gas shut-off valve to the off position, and then remove the front cover.
5. Wait five (5) minutes to clear out any gas. Then check for gas, including near the floor. If you smell gas “Stop” and follow “B” above. If you don’t detect any gas proceed to the next step.
6. Turn the gas shut-off valve to the on position, wait an addition five (5) minutes and check for gas.
7. Replace the front cover.
8. Set the thermostat to the highest setting, and then turn on all power to the appliance.
9. Ignition sequence is automatic, combustion will occur after a brief fan purge. Ignition will retry 3 times.
10. If ignition does not occur, “Turn off the gas and electricity to the appliance” and contact a professional service technician, or gas supplier.

Turning Off The Appliance

1. Set the thermostat to the lowest setting, and then turn off all power to the appliance.
2. Turn the gas shut-off valve to the off position.

13.0 TROUBLE SHOOTING

This section is intended to assist the service technician in detecting and correcting common errors. The Matrix Boiler and Fan Controls are equipped with an internal diagnostic system that verifies control operation. The following series of error codes has been developed to aid in diagnosing control problems:

Symptom	Detected Problem	Solution	
Boiler Control (Red Face)	ER1	“Water Temperature Excessive” Sentry has sensed a water temperature in excess of 250°F at the Water Sensor.	<ol style="list-style-type: none"> 1. If the boiler is extremely hot check for adequate water pressure and circulation, contact NTI for assistance. 2. If not hot, check for sources of grounding or shorting at the Water Sensor electrical connections, check wiring from Sensor to Boiler (Red) Control. 3. Replace Water Sensor if the resistance is not in the correct range. (See thermister resistance charts in Figures 13.1 and 13.2)
	ER2	“Water Sensor Short Circuit” Control has sensed a short circuit in the Water Sensor circuit.	See ER1
	ER3	“Water Sensor Open Circuit” Control has sensed an open circuit in the Water Sensor circuit.	<ol style="list-style-type: none"> 1. Check wiring to Water Sensor for open circuits or shorting to ground. (Note: ER3 will be displayed if temperature sensed is less than 0°F.) 2. Replace Water Sensor if the resistance is not in the correct range. (See thermister resistance charts in Figures 13.1 and 13.2)
	ER4	“24V Limit Error” Control has sensed a lack of 24V on the outlet of the burner relay (B1). Lockout lasts for one hour before automatically resetting.	<ol style="list-style-type: none"> 1. Reset power, if error goes away the problem is intermittent and was likely caused by a tripped limit that has automatically reset, check for adequate water pressure and flow rate. Allow the boiler to cycle and verify proper operation including outlet water temperature and flue temperature. If operation is unsuccessful and the error reoccurs: 2. Matrix boilers are equipped with a low water pressure switch on the boiler return that requires a minimum of 10PSI to complete the 24VAC ignition circuit. Ensure the field-installed pressure gauge is reading a minimum of 12PSI. Replace water pressure switch if plumbing and pressure is correct and if it measures an open circuit. 3. Check for continuity through the 24VAC limit wiring and manifold and stack limits, replace limits or wiring that are not a closed circuit.
	ER6	“Flame Lock Out” Control has sensed a lack of 24V to the gas valve during operation or a Fenwal ignition lockout.	There is a problem in the ignition sequence; it could be caused by a faulty igniter, flame sensor, gas valve or improper line pressure or combustion. Check ignition sequence to determine which component is not functioning. <i>(Control will retry ignition sequence 1 hour after ER6 code originally occurs or if control is reset)</i>
	ER9	Internal Controller Fault	Indicates that the Controller has lost communication with an internal processor, contact NTI.
	ASO Air Switch Open	This is displayed when the boiler is expecting the air switch to be closed by a differential pressure generated when the combustion blower turns on. It can occur momentarily during normal operation. A problem is indicated when ASO is displayed continuously.	<ol style="list-style-type: none"> 1. Ensure the vinyl tubes, connected between the air switch and the ports on the inlet pipe, are in the proper locations. Negative side of switch connects to the port on the 1-1/2" PVC elbow. 2. Check for blockage on the intake and exhaust vents. 3. If fan is running the air switch may be faulty, ensure it is set at 0.2"wc. 4. If fan is not running, check 120V wiring to blower, if ok remove low voltage harness from blower, if blower fails to start, replace blower, if blower does start the problem may be with blower or Controller.
	ASC Air Switch Closed	This is displayed when the boiler has turned the blower off and is expecting the air switch to be open. It can occur momentarily during normal operation. A problem is indicated when ASC is displayed continuously.	<ol style="list-style-type: none"> 1. Does the combustion fan run continuously at full speed while the error is displayed? If so check for 24V from transformer, also check transformer fuse. If 24V is present check the low voltage wiring from Controller to combustion blower, replace Controller or Blower. 2. Is the combustion fan off? If so check for water in the air switch and air switch tubes, replace switch if necessary. 3. Check venting termination with required venting described in manual.
	Controller Locks-up	Excessive noise, current, or voltage spikes in the 120V power supply.	Contact NTI.
Display Goes Blank	No power to control or control failure	<ol style="list-style-type: none"> 1. Check for 120V between terminals L1 and L2. 2. If 120V exists turn power off and remove line voltage harness from Control. Then check for resistance between L1 and L2 of control, if the circuit is open (O.L) the internal fuse has blown. Check for shorts in wires leading to circulator prior to replacing controller. (Note: If fuse is good the circuit will read between 300 and 400 Ohms.) 3. If 120V not present, check wiring and for 120V at source. 	

Matrix Installation and Operation Instructions

	Symptom	Detected Problem	Solution
Fan Controller (Blue Face)	AL1	Communication Error with HRV	<ol style="list-style-type: none"> 1. Check wiring connections between HRV and Fan Controller. 2. Check door switch on HRV. 3. Cycle power to appliance; contact NTI.
	AL2	Plenum Temperature Limit of 160°F Exceeded	<ol style="list-style-type: none"> 1. If plenum is hot, check operation of blower fan; contact NTI. 2. If plenum is not hot, check plenum sensor and wiring for shorts or damage. 3. Remove plenum sensor, PSO should be displayed, if so replace plenum sensor, if not inspect wiring from Terminal Strip to Fan Control. Replace Fan Control if necessary.
	AL5	<p>“DHW Time-Out”</p> <p>The Control has locked out DHW due to the demand lasting longer than 2.5 hours.</p>	<ol style="list-style-type: none"> 1. Reset the AL5 error by resetting the power or cycling the DHW call. Check for proper operation of the DHW call. 2. Matrix units are provided with an integrated DHW flow meter, if the control is registering a flow rate when the water is turned off; disconnect the electrical lead to the flow meter. If the indicated flow rate drops to 0, replace flow meter, if not, replace fan controller. 3. Ensure nothing is connected to the FS terminal of the terminal strip (unless using a DHW tank aqua-stat to trigger a demand – check operation of aqua-stat).
	AL7	<p>‘Boiler Control Error’</p> <p>Fan controller has failed to receive run status from Boiler Control.</p>	<ol style="list-style-type: none"> 1. Check for error code on Boiler Control. 2. Check control wiring from Boiler Control to Fan Control (Pins 17 and 18 on Fan Control – See wiring schematic in Section 8.2).
	AL8 (& Blower Off)	<p>‘Furnace Blower Error’</p> <p>Blower has failed to meet a minimum speed.</p>	<ol style="list-style-type: none"> 1. Check for 120V to blower; ensure door switches are making the circuit. 2. Check wiring from Pin 6 at Fan Control (white wire) to Pin 15 at blower motor. 3. Check for 24VDC at blower Pin 15, if present replace blower, if not replace Fan Control.
	AL8 (& Blower On)	<p>‘Furnace Blower Error’</p> <p>Control has failed to sense that the blower has reached a minimum speed.</p>	<ol style="list-style-type: none"> 1. Check wiring from Pin 5 at Fan Control (black wire), to Pin 16 at blower motor. 2. Check for 3-5VDC at blower Pin 16, if present replace blower, if not replace Fan Control.
	F3.5 Flashing	Lack of 24 V at fan controller	<ol style="list-style-type: none"> 1. Check/Replace 2A fuse – blown fuse indicates 24V supply shorted to ground, or excessive load.
Fenwal	Two Flashes on Fenwal	The Fenwal controller thinks that there is a flame prior to ignition. Indicates Ignition Lockout.	If the combustion sequence is normal, and there is no flame prior to ignition, the Fenwal control is defective, and must be replaced.
	Three Flashes on Fenwal	“Ignition Lockout”	<p>If the condensate drain gets blocked, the boiler will become flooded and terminate operation as the flame rod becomes immersed. This will damage the flame probe. To correct, free the drain blockage, and permanently prevent it from reoccurring. Remove and dry off the probe. Reinstall the probe and try for ignition, if it fails to stay lit, leave the fan run for up to three hours to dry out the insulation and probe.</p> <ol style="list-style-type: none"> 1. Reset Boiler so it will attempt to ignite. 2. Check for proper operation of ignition components. Make sure igniter glows and gas valve opens. 3. Check for proper line pressure at gas valve when it opens. 4. If boiler lights check for flame signal between FC1 and FC2 on Fenwal control (If lower then 1.2 DC μAmps see “Boiler will not stay lit”). 5. Check combustion properties.

Matrix Installation and Operation Instructions

	Symptom	Detected Problem	Solution
General	Boiler will not stay lit.	Indicates lack of a flame signal. In order to stay running the flame signal must be at least 0.7 μ Amps	<ol style="list-style-type: none"> 1. If the Burner light on the Burner (Red) Control is going out, go to "Burner shutting off". 2. Check condensate drain for blockage and check the inlet piping for ingested snow or water (if the flame rod gets wet, it may need to be replaced). Check for resistance from flame rod to ground, must be an open circuit (O.L.), if not, remove rod and bend it away from the burner slightly. 3. Check for proper polarity of line and neutral wiring to the boiler.
	Boiler bangs or hisses	Bangs or sounds like a kettle while burner is running indicates insufficient flow	<ol style="list-style-type: none"> 1. Ensure the plumbing is as shown in manual. Check to see if pumps are operating properly and water pressure is above 15psi. This problem can lead to boiler overheating! 2. Boiler may be plugging with scale or magnetite, clean with Fernox DS-40 Descaler and Cleanser (NTI PN: 83450). 3. If glycol is being used the concentration may be too high, recommend using a concentration lower than 35%.
	Boiler Lights rough or pulsates	Typically an imbalance in the Air to gas ratio	<ol style="list-style-type: none"> 1. Ensure that the venting lengths are in compliance with Section 3.4 2. Ensure that the line pressure during operation does not drop more than 20% from the static line pressure. 3. Momentarily remove the intake vent from the boiler during ignition, if unit lights smoothly with intake vent disconnected reconnect and check for proper combustion if unit maintains smooth operation after ignition. (See Section 5.2) Calibrate for proper combustion. If problem persists contact NY Thermal. 4. Heat exchanger may be dirty, remove burner door and inspect, clean if necessary.
	Fan appears to be creating a noise in the house	Slight vibration can cause noise in the residence (This is not a warranty issue)	
Making a rubbing noise. ((This is not a warranty issue))			<ol style="list-style-type: none"> 1. If gas valve is not held when the gas nipple is connected, the force of tightening the fitting can damage the valve, and warp the fan housing. 2. If pipe is used, the gas line must not create any forces to the valve, either vertically (weight of line), or horizontally (misaligned connection)

The following are the thermistor curves for diagnosing the water and outdoor air sensors:

Measure the resistance of the thermistor when disconnected.

Using the appropriate chart, find the resistance and move either vertical (water probe) or horizontal (air probe) until the line is intersected.

Move 90 degrees to the corresponding temperature.

If the temperature is plus or minus 10 degrees, then the probe is operating correctly.

Figure 13.1 Matrix Thermistor Resistance Chart
1 Mohm Water Probe (Low Temp.)

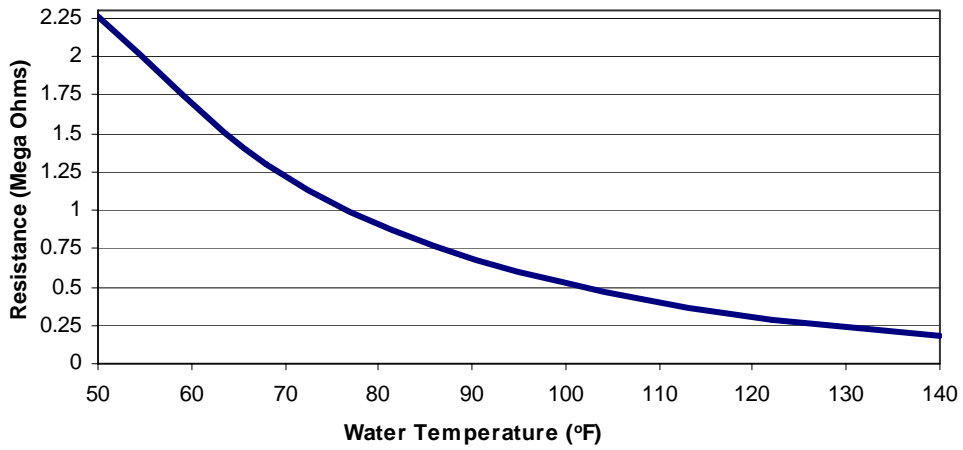

Figure 13.2 Matrix Thermistor Resistance Chart
1 Mohm Water Probe (Hi Temp.)

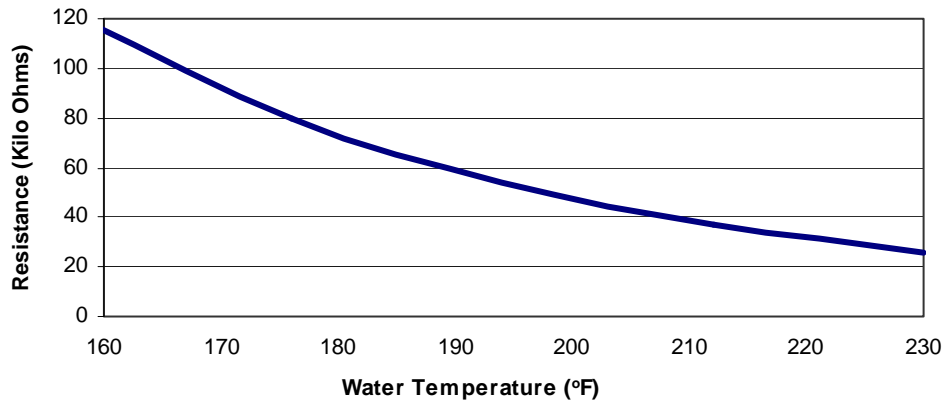
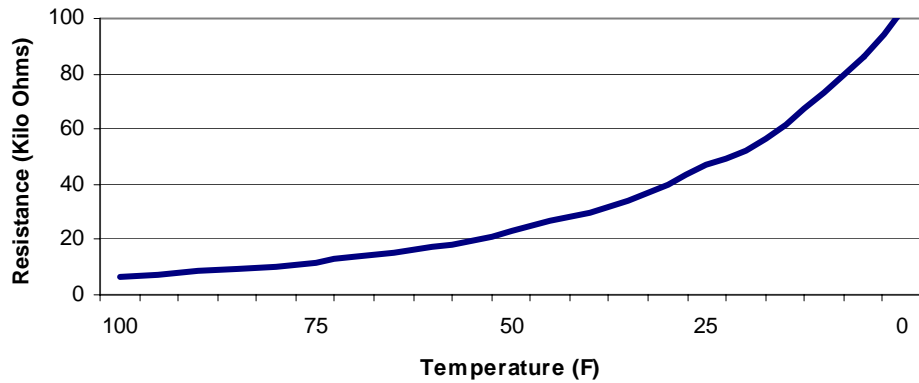
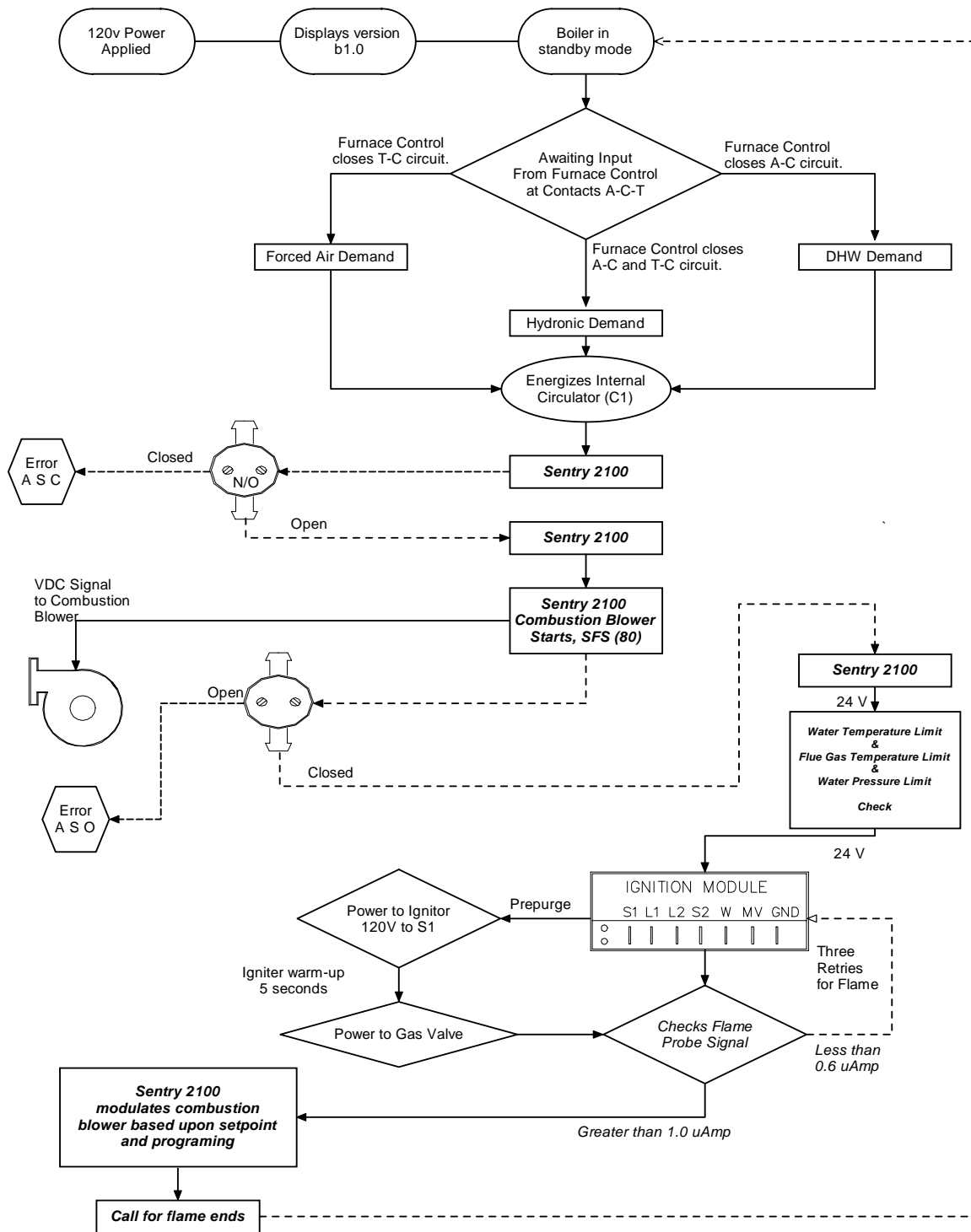

Figure 13.3 Outdoor 10K probe



14.0 SEQUENCE OF OPERATION

Figure 14.1 Matrix Boiler Control Sequence Of Operation



15.0 INSTALLATION CHECKLIST

Installation

- 1. If operating on Propane Gas, convert appliance using kit number 82650-1.
- 2. Install the Vent/Air-Intake piping in accordance with Sections 3.0 this manual. Ensure all joints are secured and cemented properly. Both the Vent and Air-Intake pipes must terminate outdoors. Perform the **Mandatory Pre-commissioning Procedure for Plastic Venting** in Section 3.1.
- 3. Connect the condensate drain in accordance with Section 4.0 of this manual.
- 4. Connect the gas supply in accordance with Section 5.0 of this manual.
- 5. Install the plumbing in accordance with the Sections 6.0 and 7.0 of this Manual. Flush/cleanse the internals of the heating system (hydronic piping of hydronic systems only). Treat system water with Fernox F1 Protector.
- 6. Connect field wiring in accordance with Section 8.0 of this manual.
- 7. Advise home/building owner of their responsibilities with respect to maintaining the appliance.



The building owner is responsible for keeping the Vent/Air-Intake termination free of snow, ice, or other potential blockages and for scheduling routine maintenance on the appliance (see Section 16.0). Failure to properly maintain the appliance may result in serious injury or death.

Start-up



Allow primers/cements to cure for 8 hours prior to Start-up. If curing time is less than 8 hours, first perform Steps 2 through 6 of **Mandatory Pre-commissioning Procedure for Plastic Venting** in Section 3.0. Failure to follow these instructions can result in explosion, serious injury or death.

- 1. Turn gas shut-off valve to the ON position.
- 2. Turn Power on to appliance.
- 3. Set Controller to the desired settings.
- 4. Turn thermostat up, Ignition will occur.

Operational Checklist

- 1. System is free of gas leaks.
- 2. System is free of water leaks.
- 3. Water pressure is maintained above 15 PSI.
- 4. All air is purged from the heating system piping.
- 5. Ensure proper water flow rate; unit must not kettle, bang, hiss or flash the water to steam.
- 6. Ensure gas line pressure is in accordance with Section 5.0.
- 7. System is free of combustion leaks.
- 8. Unit must operate smoothly.
- 9. Ensure the flue gas combustion readings are within the tolerances listed in Table 5.1.
- 10. Each ignition must be smooth.
- 11. Verify that all condensate lines are clean and drain freely.

Before Leaving

- 1. Remove line pressure gauge from gas valve, tighten bleed screw, test screw for leaks. See Section 11.0.
- 2. Install plug into the flue gas test port and test for leaks.
- 3. Allow the appliance to complete at least one heating cycle, or to operate for at least 15 minutes.
- 4. Always verify proper operation after servicing.

Instructions to Installing Contractor

- 1. Ensure that the customer receives the Warranty Documentation included with the installation manual.
- 2. Leave the manual with the customer so they know when to call for annual maintenance and inspection.



This appliance must have water flowing through it whenever the burner is firing. Failure to comply may damage the unit, void the warranty, and cause serious injury or death.



Allowing the appliance to operate with a dirty combustion chamber will adversely affect its operation and void the warranty. Failure to clean the heat exchanger on a frequency that matches the need of the application may result in fire, property damage, or death.

16.0 ANNUAL MAINTENANCE AND INSPECTION

This unit must be inspected at the beginning of every heating season by a Qualified Technician.

Annual Inspection Checklist

- 1. Lighting is smooth and consistent, and the combustion fan is noise & vibration free.
- 2. The condensate freely flows from the unit, and is cleaned of sediment.
- 3. Relief Valve and air vents are not weeping.
- 4. Low water cut off is flushed (if applicable)
- 5. Examine all venting for evidence of leaks. Ensure vent screens are cleaned and clear of debris.
- 6. Check the burner plate for signs of leaking.
- 7. The combustion chamber must be inspected and cleaned.
- 8. Listen for water flow noises indicating a drop in appliance water flow rate.

Important - The hydronic system may need to be flushed to eliminate hard water scale
(Use Fernox DS-40 Descaler, NTI PN: 83450).

IMPORTANT

Boiler system cleansers and corrosion inhibitors must not be used to flush contaminants from water heaters or potable water systems.

16.1 Combustion Chamber Cleaning Procedure

Units operating with LP Gas or in an industrial environment will have to be cleaned a minimum of once per year. Other applications will require the combustion chamber to be cleaned after the first year of operation, with subsequent cleanings scheduled based on the condition of the combustion chamber at the time. Unless a step is identified as model specific, the following combustion chamber cleaning procedure is the same for all models.

IMPORTANT

Crystalline Silica - Read carefully the warnings and handling instructions pertaining to Refractory Ceramic Fibers before commencing any service work in the combustion chamber. Take all necessary precautions and use recommended personal protective equipment as required.

- 1. Initiate a post-purge cycle to clear any gas from the combustion chamber, then turn gas valve off.
- 2. Access the combustion chamber by removing the aluminum burner door assembly of the appliance.
- 3. Remove the insulation disc (P/N 83112) located in the back of the combustion chamber to avoid damaging it during the cleaning process. The disc is held in place with a 2.5mm "Allen-head" screw.
- 4. Use a vacuum with a high efficiency filter to remove any loose debris or dust.
- 5. Wet the inside of the combustion chamber with water. Use a garden hose with a trigger nozzle to direct pressurized water through the gaps between the heat exchanger tubes. The water should pass in-between the heat exchanger tubes and exit via the condensate drain. This process may require the use of some dry rags or plastic to protect electrical components from being damaged by dripping or spraying water.
- 6. Use a nylon or other non-metallic brush to loosen the incrustations and any other contaminants that have remained stuck on and in-between the tubes.
- 7. Repeat steps 5 and 6 until the heat exchanger is clean and water from the condensate drain runs clear.
- 8. Re-install the insulation disc (part no. 83112) to the back of the combustion chamber.
- 9. Inspect the insulation disc located on the back-side of the burner door (p/n 82769). Replace if damaged.
- 10. Re-install the burner door, gas-supply and Air-inlet pipe, check for gas leaks.
- 13. Perform the Operational Check List detailed in Section 13.0.

WARNING

Replace any gaskets or insulation discs that show any signs of damage and do not re-use. Failure to follow these instructions may result in fire, property damage or death.

Refractory Ceramic Fibers (RFC)



Personal Protective Equipment Recommended - Read the following warnings and handling instructions carefully before commencing any service work in the combustion chamber. The insulating material on the inside of the burner door and at the back of the combustion chamber contain *Refractory Ceramic Fibers* and should not be handled without personal protective equipment.



Potential Carcinogen - Use of *Refractory Ceramic Fibers* in high temperature applications (above 1000°C) can result in the formation of Crystalline Silica (cristobalite), a respirable silica dust. Repeated airborne exposure to crystalline silica dust may result in chronic lung infections, acute respiratory illness, or death. Crystalline silica is listed as a (potential) occupational carcinogen by the following regulatory organizations: International Agency for Research on Cancer (IARC), Canadian Centre for Occupational Health and Safety (CCOHS), Occupational Safety and Health Administration (OSHA), and National Institute for Occupational Safety and Health (NIOSH). Failure to comply with handling instructions in Table 14-1 may result in serious injury or death.



Crystalline Silica - Certain components confined in the combustion chamber may contain this potential carcinogen. Improper installation, adjustment, alteration, service or maintenance can cause property damage, serious injury (exposure to hazardous materials) or death. Refer to Table 14-1 for handling instruction and recommended personal protective equipment. Installation and service must be performed by a qualified installer, service agency or the gas supplier (who must read and follow the supplied instructions before installing, servicing, or removing this appliance. This appliance contains materials that have been identified as carcinogenic, or possibly carcinogenic, to humans).

Table 16.1 Handling Instructions for Refractory Ceramic Fibers (RCF)

Reduce the Risk of Exposure	Precautions and Recommended Personal Protective Equipment
Avoid contact with skin and eyes	<ul style="list-style-type: none"> Wear long-sleeved clothing, gloves, and safety goggles or glasses.
Avoid breathing in silica dust	<ul style="list-style-type: none"> Wear a respirator with a N95-rated filter efficiency or better.¹ Use water to reduce airborne dust levels when cleaning the combustion chamber. Do not dry sweep silica dust. Pre-wet or use a vacuum with a high efficiency filter.
Avoid transferring contamination	<ul style="list-style-type: none"> When installing or removing RFCs, place the material in a sealable plastic bag. Remove contaminated clothing after use. Store in sealable container until cleaned. Wash contaminated clothing separately from other laundry.
First Aid Measures	<p>If irritation persists after implementing first aid measures consult a physician.</p> <ul style="list-style-type: none"> Skin - Wash with soap and water. Eyes - Do not rub eyes; flush with water immediately. Inhalation – Breathe in fresh air; drink water, sneeze or cough to clear irritated passage ways.

Notes:

¹ Respirator recommendations based on CCOHS and OSHA requirements at the time this document was written. Consult your local regulatory authority regarding current requirements for respirators, personal protective equipment, handling, and disposal of RCFs.

For more information on Refractory Ceramic Fibers, the risks, recommended handling procedures and acceptable disposal practices contact the organization(s) listed below:

Canada (CCOHS): Telephone directory listing under Government Blue Pages Canada—Health and Safety—Canadian Centre for Occupational Health and Safety; or website <http://www.ccohs.ca>.

United States (OSHA): Telephone directory listing under United States Government—Department of Labor—Occupational Safety and Health Administration; or website <http://www.osha.gov>.

16.2 HRV/Air Handler Maintenance

 **WARNING**

ALWAYS REMOVE POWER (120V) TO THE UNIT PRIOR TO SERVICING.

Once every three months. Replace furnace filter. May be required more frequently in beginning, especially if new construction.

The Matrix HRV module is relatively maintenance free but does require routine cleaning. Table 14 describes the necessary maintenance.

Table 16.1 HRV Maintenance Items

Heat Recovery Core	Annually or as needed	Vacuum surfaces, let soak in warm water for three hours, spray rinse and let dry
Energy Recovery Core	Annually or as needed	Vacuum surfaces
Filters	Every 3 months or as needed	Vacuum Filters
	Annually or as needed	Replace filters
Inside Surfaces of Unit	Annually or as needed	Clean interior of unit (walls and drain pan) with a mild non-abrasive soap. It is recommended to use products that are environmentally friendly

17.0 PARTS LIST

Replacement parts are available from your stocking wholesaler. Homeowners must contact their local Installer or Wholesaler. Installers or Wholesalers may contact NY Thermal Inc. for assistance at 506-657-6000.

No.	P.N.	Description
1	82657	Premix burner, 1358
1A	82761	Premix Burner Gasket
2	83190	Transformer, 24V
3	83083	Matrix Fan Control
3A	83160	Matrix Boiler Control (Sentry 2100)
4	82052	Blower #RG130
5	82054	Gas Valve (CVI) VK81 15F1134B
5A	82065	Gas Valve 1/2" npt elbow
5B	82600	Gas Valve Vent connection
6	82662	Air switch Huba @ .2"wc.
7	83035	Thermister, 1/4"NPT
8	82058	Ignition Module (Fanval)
9	82708	IGNTER, #601, c/w SS shield
10	82762	Rauschert Flame Rod
11	82763	Composit Flue Box
11A	82764	Composit Flue Box Gasket
11B	82765	Composit Flue Outlet Gasket
11C	83291-3	Flue Adapter Assembly (4.5")
12	82992	Manifold Limit, 1/4NPT
13	82596	Heat Exchanger (Canada)
13	83012	Heat Exchanger (US)
14	82650	LP orifice 5.20mm
15	82660	Stack Limit, 1/4BSP, 190F, Df=30
16	82766	Blower Outlet Gasket
17	82368	3/4" Water Connection Gasket
18	83042	Condensate Y Drain
18A	82913	Siphon Condensate Trap
19	82767	Cast aluminum Burner door
19A	82769	Ceramic burner door disc
19B	82770	Burner door gasket
20	82768	Igniter gasket
21	82228	Tempering valve #AM101-US-1
22	82771	Extended air tube
23	82011	Plate heat exchanger LA1430
24	83507	Flow Meter
25	82160	3 way Valve VU54S2016B, 3/4"
26	82973	3 way actuator VU844A1003B
27A	82754-1	PCB Optocoupler
28	82054-1	CVI Venturi 01
28A	82054-2	CVI Venturi Gasket
29	82622-3	Matrix Air Metering Assembly
30	81027-1	Outdoor Air Sensor
31	83223-1	Pressure Switch 1/4"NPT
32	83112	Divider Plate Insulation (c/w hardware)
33	83462	Tee, Brass, 1/4"
34	53035	Furnace Blower
35	83081	ECM Motor
36	82285	Expansion Tank
37	81396	Grc. Pump Grundfos UP15-42B7
38	83363	Fin Tube Coil 22.5" x 18"
39	83547	HRV Fan
40	83548	HRV/HVC Board
41	83549	HRV Filter x 2
42	83550	HRV Core
43	83555	HRV Damper Actuator (24V)
44	83084	Matrix HRV Assembly
45	83222	Matrix Plenum Sensor
46	83208	Door Safety Switch
47	82539	Auto Air Vent, 1/8"
48	83551	6" Double Collar
49	83552	Keeper for 6" Collar
50	83553	HRV Door Switch

