

# *Installation and Maintenance instructions*



*Supplemental Instructions*  
*For*  
**Odyssey (Balanced Flue)**

*Save these instructions*

## 1.0 SETTINGS & TECHNICAL DATA

### Riello BF 40 Series (Direct Vent)

Model	Input GPH	Output BTU	Pump (PSI)	Delavan 60°W	Riello BF 5 Burner		CO <sub>2</sub>	Smoke Number
					Turbulato r	Air Gate		
CT 80	Discontinued							
CT 90	.75	89,000	133	.65	0	4	10.5	Trace
CT 100	.85	101,000	128	.75	0	5	10.5	Trace
CT 120	1.00	124,000	138	.85	1.5	6	11.5	Trace

### Air Settings

**All testing must be done with the burner cover in place, and all venting securely tighter. Set air to obtain combustion at trace or 0 smoke, with a CO<sub>2</sub> between a maximum of 11.5%, and a minimum of 10%.**

Draft settings- Due to the design of the balanced flue system, the Odyssey will operate at a positive draft pressure and a positive over fire pressure at all times. It is design to operate with a maximum stack draft of 0.25" W.C and a maximum over fire draft of 0.33" W.C. when little or no wind is present. In extreme wind conditions, the maximum stack draft is 0.35" W.C. and the maximum over fire draft is 0.45" W.C. .

## 2.0 INSTALLATION COMPONENTS

Following is a list of the parts included in the balance flue kits with their part numbers.

### Contents of Vent kit

<i>PART #</i>	<i>DESCRIPTION</i>
81746	5" TO 3" PORTED ADAPTER
?	3" FLEX TO PIPE ADAPTOR
81114	DIRECT VENT TERMINAL
81123	4" TO 3" INCREASER (BECKETT ONLY)
81124	3000 Ω RESISTOR
	3" FLEX x 10'

The insulated flex section for the exhaust has to be ordered separately.

<i>PART #</i>	<i>DESCRIPTION</i>
81111	20 FEET INSULATED FLEX
81110	15 FEET INSULATED FLEX
81097	10 FEET INSULATED FLEX
81109	5 FEET INSULATED FLEX

## 3.0 INSTALLATION CODES

Install the balanced flue system according to **CSA S139** codes to ensure a safe operation of your unit.

The following guidelines are included in the CSA codes and must be respected at all times:

**A)** Use approved venting components only.

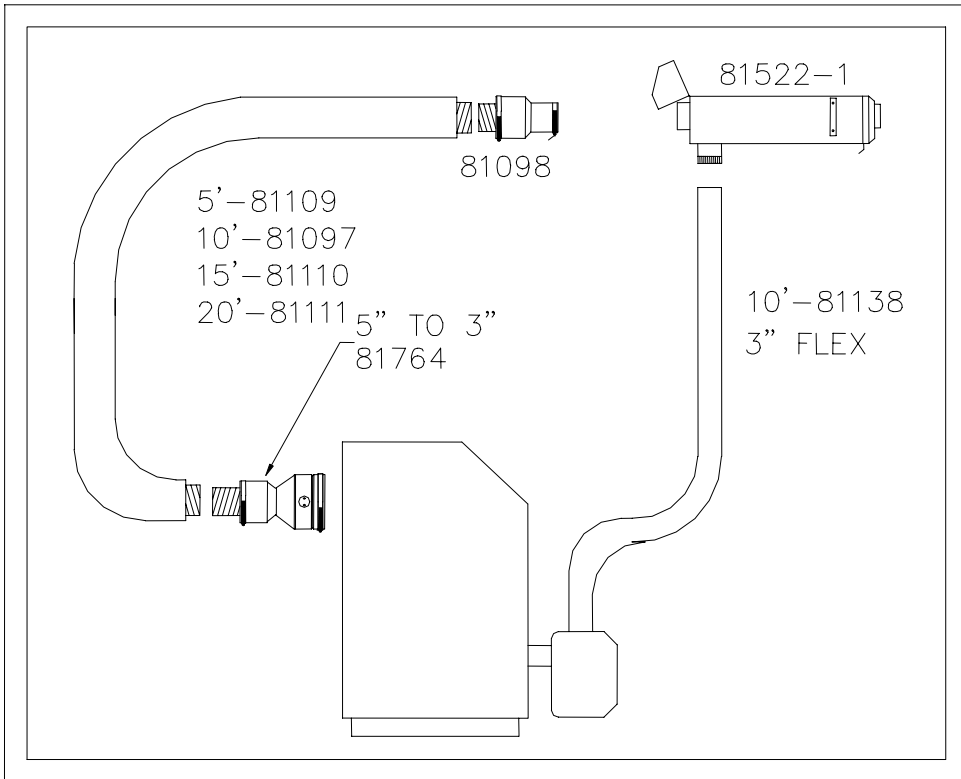

- B)** The vent and air intake maximum length is 20 ft (6 m)
- C)** The vent must be in one continuous piece with no joints.
- D)** Combustion air intake and the vent must be installed on the same wall to ensure that the system is balanced.
- E)** Vent terminal shall not terminate:
- closer than 6 ft (1.8 m) from the property line
  - any closer than 6 ft (1.8 m) from another NY Thermal vent terminal or combustion air inlet for any other appliance .
  - Above a gas meter/regulator assembly within 3 ft. (0.9m) horizontally of the vertical centerline of the regulator.
  - any closer than 6 ft (1.8 m) of any gas service regulator vent outlet
  - Above a paved sidewalk or a paved driveway if the following serves two buildings and is located between them.
  - Any closer than 7 ft (2.13 m) above any paved sidewalk or paved driveway.
  - Any closer than 3-ft (0.9 m) of an oil tank vent or an oil tank inlet.
  - Any closer than 6-ft (1.8 m) of a door, window, another NY Thermal vent terminal or mechanical air supply inlet to any building (includes soffit openings).
  - In a location where the flue gases are directed at combustible material that are within 6-ft (1.8 m).

- With the bottom of the vent termination opening less than 1-ft (0.3 m) above any surface that may support snow, ice, or debris.
- With its flue gases directed towards siding, brickwork, or other construction, in such a way that may cause damage from heat or condensate from the flue gases.
- Within 1 ft (0.3 m) above grade (ground or any surface that will support snow).
- underneath a deck, porch, or veranda
- closer than 6 ft (1.8 m) from an inside corner of an L-shaped structure
- In a location where the flue gases are directed at any opening of surrounding buildings that are within 6-ft (1.8 m).

**See instruction sheet NYT.2V-2.0 for multiple vent terminal arrays.**

**NOTE:** Even if all the installation codes are met, good judgement and common sense must also be used for selecting an appropriate location for the balanced flue intake and outlet.

## 4.0 Venter Installation Steps

1. Select a suitable location for the vent terminal, It is highly recommended that the vent terminal be located where it will not be exposed to normal prevailing winds. See the back of this sheet for code restrictions.

**NOTE: Under normal operating conditions this appliance will produce a plume of white gases, and should be taken into consideration when selecting an adequate location.**

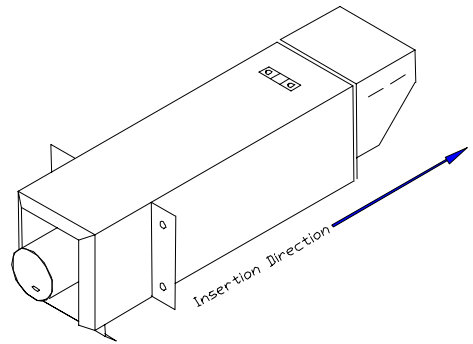

2. Ensure that the outside wall surface is flat and meets the installation restrictions.
3. Cut a rectangular hole, 5.5" wide, and 6" in height.
4. Insert the vent terminal through cut hole so that the 3" diameter hole at the back is facing down.
5. Secure vent terminal to the side of the structure using 4- #10 stainless steel Screw.
6. Using a suitable silicone sealant, caulk the gap between the structure and the vent terminal.

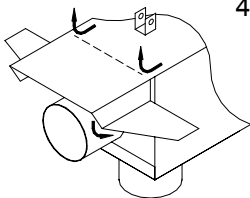

7. **When installed correctly, the vent terminal pipe should be pointing slightly uphill in order to drain water to the outside.**

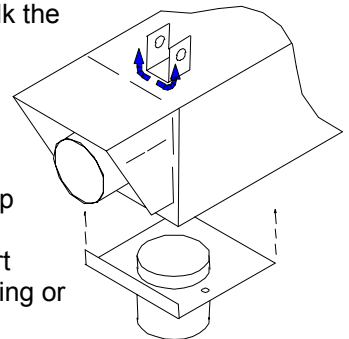

8. Using a screwdriver, bend **up** the support bracket located on the top of the unit as shown.
9. Support the back end of the vent terminal by connecting the support bracket to a joist, or other solid structure, by means of metal strapping or wire.
10. Using the screws provided, attach the air inlet connection flange to the bottom of the vent terminal.

11. The back of the vent terminal is equipped with a flexible heat shield, bend the flaps to the side, and then bend the heat shield up, and out of the way.
12. Silicone caulk the space between the vent terminal and the structure.
13. Install the fresh air piping over vertical 3" end, and tighten with a 3" gear clamp (not provided).

The boiler can now be connected to the exhaust terminal with the help of insulated flex piping. The flex is available in lengths of 5 ft, 10 ft, 15ft, and 20 ft. Make sure that it's long enough to form long radius bends (no smaller than 1 ft in radius). If the flex is too long, it can be cut with a hacksaw. Assemble pipe as detailed in **Section 5**.

## **5.0 CAULKING**

**WARNING THIS BALANCED FLUE SYSTEM WILL LEAK IF THE FOLLOWING CAULKING PROCEDURES ARE NOT FOLLOWED. IT'S EASIER TO SEAL THE ENTIRE SYSTEM PROPERLY THE FIRST TIME THAN RETURN AT A LATER DATE AND HAVE TO REMOVE THE CONNECTIONS TO RESEAL IT.**

The caulking instructions are included in the installation section, but this section has more details

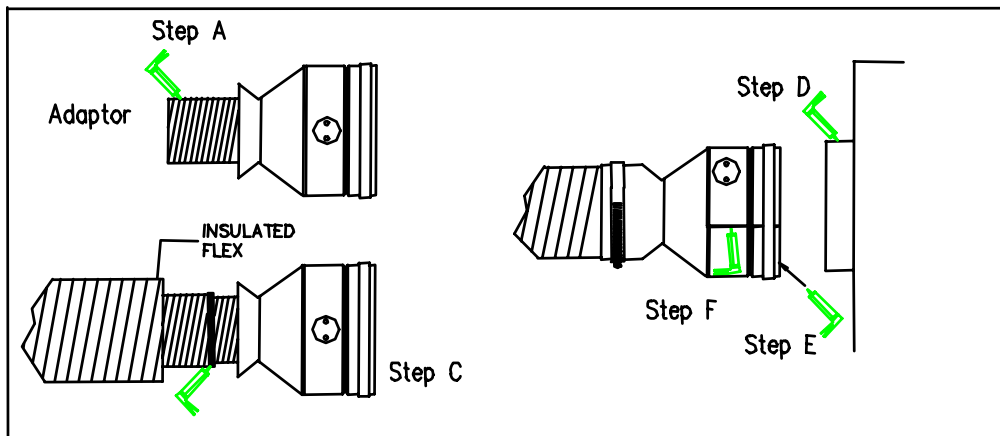

**NOTE:** - The adapters are multi-start, left hand thread, with one thread twice the width of the others. Therefore, care must be taken to ensure that the correct threads are engaged before tightening in a counter clockwise direction.

***The vent must have 9" clearance to combustible within 36" of the appliance breach. The remaining section of the vent to the terminal can have a minimum of 1" clearance. The terminal is rated for 0" clearance.***

Because the balanced flue system operates with a positive pressure in the exhaust at all times, the caulking has to be done properly to prevent leaks at the joints. The type of caulking used throughout this installation is critical to the operation of the balanced flue system. A tube of caulking is provided with the installation kit. This tube should be sufficient for the whole installation, but if more caulking is needed buy one of the following: GE 106, Dow Corning 736 Heat Resistant Sealant, Perimeter 248 High Temp or RTV Silicone Gasket.

***Follow these steps to obtain a good seal.***

***Boiler***

Inspect all boiler openings (sight door, burner connection, pipe joints, Etc) during initial operation, to verify that there are no leaks.

***Flex Pipe***

***Make sure that it's long enough to form long radius bends (no smaller than 1 ft radius). If the flex is too long, it can be cut with a hacksaw.***

***It is recommended to remove the collar on the 81089 & 81112 flex adapters that secures the insulation and outer foil of the Flex pipe. Removing the pop rivet at the base of the collar, and backing off the gear clamp completely can best accomplish this. After removing the collar, you will get a perfect unobstructed view of the pipe joint. To reinstall, put the collar back into place and install a #8x½" screw in rivet hole, and re-thread the gear clamp.***

- A. Put 1 bead of silicone on both outside ends of 81089 & 81112 connectors, approximately 1" wide and 1" from the bottom of the threads.
- B. Pull the outer foil sheathing and insulation back as far as possible, to give an unobstructed view of the pipe joints. Put 1 bead of silicone on both inside ends of the insulated flex pipe, approximately 1" wide and ½" from the end. Screw in part number 81089 & 81112 adapters into the insulated flex and pull the insulation and the outside flex over the collar and tighten the gear clamp.
- C. Apply a wide bead on top of the flex joint. Reinstall the collars on the vent connectors using a #8x½" screw in rivet hole, and re-thread the gear clamp
- D. Apply silicone on outside surface of the boiler cast collar.
- E. Apply silicone on inside surface of the 5"-3" adapter
- F. Apply silicone between the vertical overlap joint of the 5"-3" adapter.
- G. Apply silicone on outside surface of the boiler collar, and slide 5"-3" adapter over the smoke hood and tighten the gear clamp.
- H. Perform steps B install the 3" adapter #81089 over the 3" pipe of vent terminal, and tighten gear clamp.
- I. Fold the vent terminal heat shield flaps back into position.

**NOTE:** - It's the **installer's responsibility** to ensure that the combustion products do not enter the home.

**6.0 CLEANING**

Do not remove the 5" to 3" adapter from the breech or any of the other exhaust connections for cleaning the Odyssey. Follow the typical boiler cleaning routine.

## 7.0 WIRING

All wiring must be in accordance with the Canadian Electrical code, CSA C22.2, and any local codes that may become applicable. Insure that the wiring is in accordance with this manual. The boiler must be electrically grounded in accordance with local codes, and C22.2.

### ***Important Warning***

***It is the responsibility of the installer to ensure that:***

- The boiler and venting system are totally sealed from products of combustion.
- The homeowner is advised of their responsibility of keeping the vent terminal clear of snow and ice.
- That the home is equipped with a carbon monoxide sensor.

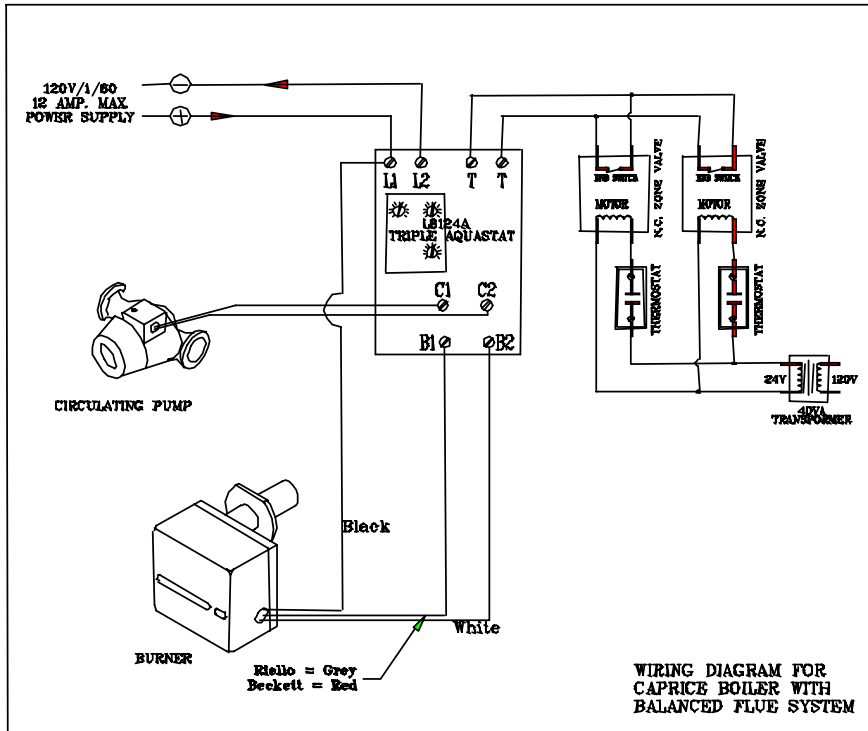

ODYSSEY WIRING DIAGRAM FOR SENTRY 2100 (direct Vent)

